

DATA SHEET

For a complete data sheet, please also download:

- The IC04 LOCMOS HE4000B Logic Family Specifications HEF, HEC
- The IC04 LOCMOS HE4000B Logic Package Outlines/Information HEF, HEC

HEF4755V

LSI

Transceiver for serial data communication

Product specification
File under Integrated Circuits, IC04

January 1995

Transceiver for serial data communication

HEF4755V LSI

DESCRIPTION

The HEF4755V transceiver is a circuit for serial data communication. It provides maximum transmission security and effectiveness. Therefore, in addition to the normal precautions, it contains a programmable digital bit-check, a programmable CRC (Cyclic Redundancy Check; Hamming distance 4 or 6) and format protection.

The circuit has 8 possible operating modes:

- synchronous
 - error checking only
 - receiving
 - transmitting
 - receiving with data out and transmitting the same message
- asynchronous
 - error checking only
 - receiving
 - transmitting
 - receiving with data out and transmitting of a regenerated message.

FEATURES

- Transmission rate:

V _{DD}	SYNCHRONOUS	ASYNCHRONOUS
5 V	0,8 Mbaud	31 kbaud
7 V	1,6 Mbaud	62 kbaud
10 V	3,2 Mbaud	125 kbaud

- Inputs: standard LOCMOS
- Outputs: TTL compatible (1 TTL load)
- Operating ambient temperature range: -40 to + 85 °C
- Transmit or receive a serial binary data stream
- Start bit generation and recognition
- Format protection and checking
- Redundancy byte generation and checking
- Digital bit check
- Error recognition and error distinguishing
- 8-bit parallel input/output transfer

SUPPLY VOLTAGE/CURRENT

	RATING	RECOMMENDED OPERATING
V _{DD}	-0,5 to +15	4,75 to 12,6 V
I _{SS}	30	- mA

FAMILY DATA, I_{DD} LIMITS category LSI

See Family Specification

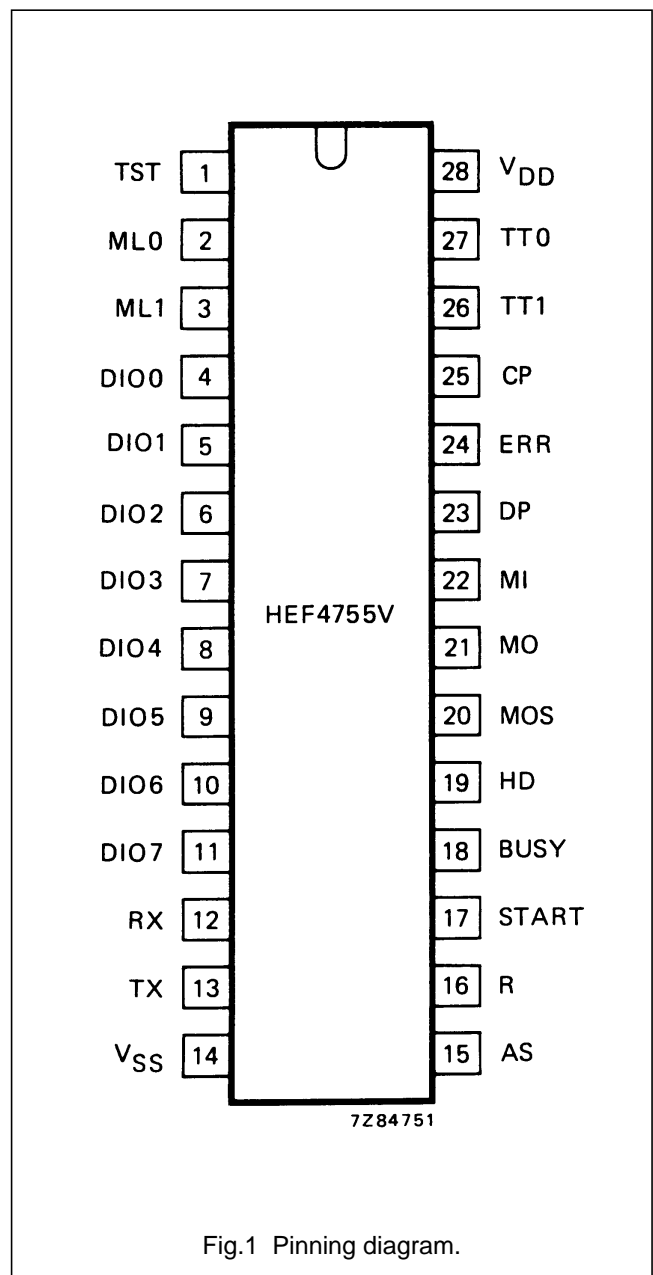

Transceiver for serial data communication

HEF4755V
LSI

HEF4755VP(N): 28-lead DIL; plastic
(SOT117-2)
HEF4755VD(F): 28-lead DIL; ceramic (cerdip)
(SOT135)
HEF4755VT(D): 28-lead SO; plastic
(SOT136-1)

(): Package Designator North America

PINNING

1	TST	Test pin; during normal use connected to V_{SS} . When TST is HIGH (V_{DD}), internal check points are connected to the data bus.	19	HD	Hamming distance; determines the length of the redundancy byte: LOW = 7 bit (HD = 4) HIGH = 15 bit (HD = 6)
2	ML0	Input code for message length (see Table 1).	20	MOS	Output message synchronization used in synchronous mode.
3	ML1		21	MO	Message output.
4	DIO0	Bidirectional data bus.	22	MI	Message input.
to	to		23	DP	Output data pulse; take-over pulse for data on the data bus.
11	DIO7		24	ERR	Output error; an active output means that at least 1 transmission error is recognized.
12	RX	Mode input: receive; see Table 2	25	CP	Clock input; in synchronous mode equal to the transmission bit rate.
13	TX	Mode input: transmit; see Table 2	26	TT1	Programming of the permissible time tolerance in bit distortion (see Table 3).
15	AS	Mode input: asynchronous; see Table 2	27	TT0	
16	R	Reset; a positive signal resets all internal registers.	28	V_{DD}	Positive supply voltage; 4,5 V to 12,5 V (is the logic HIGH level).
17	START	Input start in transmitting mode; synchronization input (from MOS) in synchronous receiving mode.	14	V_{SS}	Ground (is the logic LOW level).
18	BUSY	Output busy; active during receiving or transmitting a message.			

Transceiver for serial data communication

HEF4755V
LSI**Table 1** Input code for message length

ML0	ML1	MESSAGE LENGTH
H	H	6 data bytes
L	H	4 data bytes
H	L	2 data bytes
L	L	variable length depends on format byte

Table 2 Input code for input mode

RX	TX	AS	
L	L	L	status register connected to the data bus for error recognition
H	L	L	receiving in synchronous mode
L	H	L	transmitting in synchronous mode
H	H	L	receiving messages (without redundancy bit); data parallel out; calculating of redundancy byte; transmitting data with redundancy byte in synchronous mode
L	L	H	only bit check in asynchronous mode; no data output on data bus
H	L	H	receiving in asynchronous mode
L	H	H	transmitting in asynchronous mode
H	H	H	receiving and transmitting of a regenerated message in the asynchronous mode

Table 3 Permissible time tolerance in bit distortion

TT1	TT0	PERMITTED DISTORTION (dt/T)
L	L	6/32 ≈ 19%
L	H	8/32 = 25%
H	L	10/32 ≈ 31%
H	H	12/32 ≈ 37%

Notes

1. H = HIGH state (the most positive voltage)
2. L = LOW state (the least positive voltage)

Transceiver for serial data communication

HEF4755V
LSI

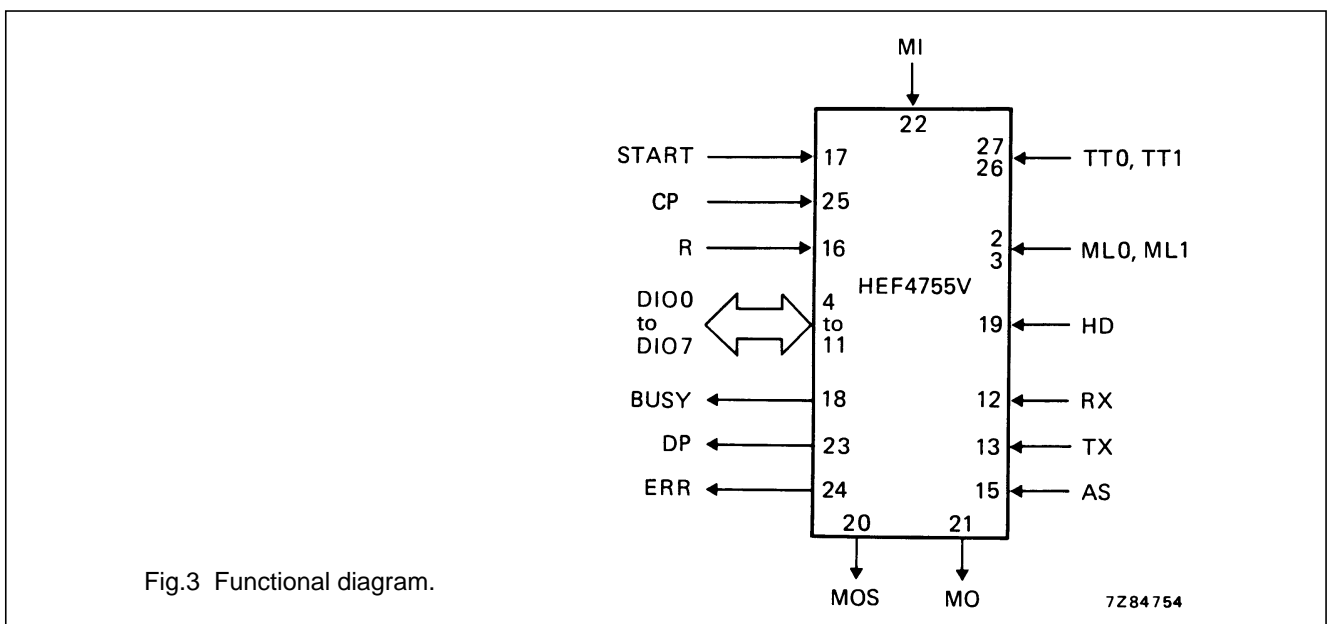
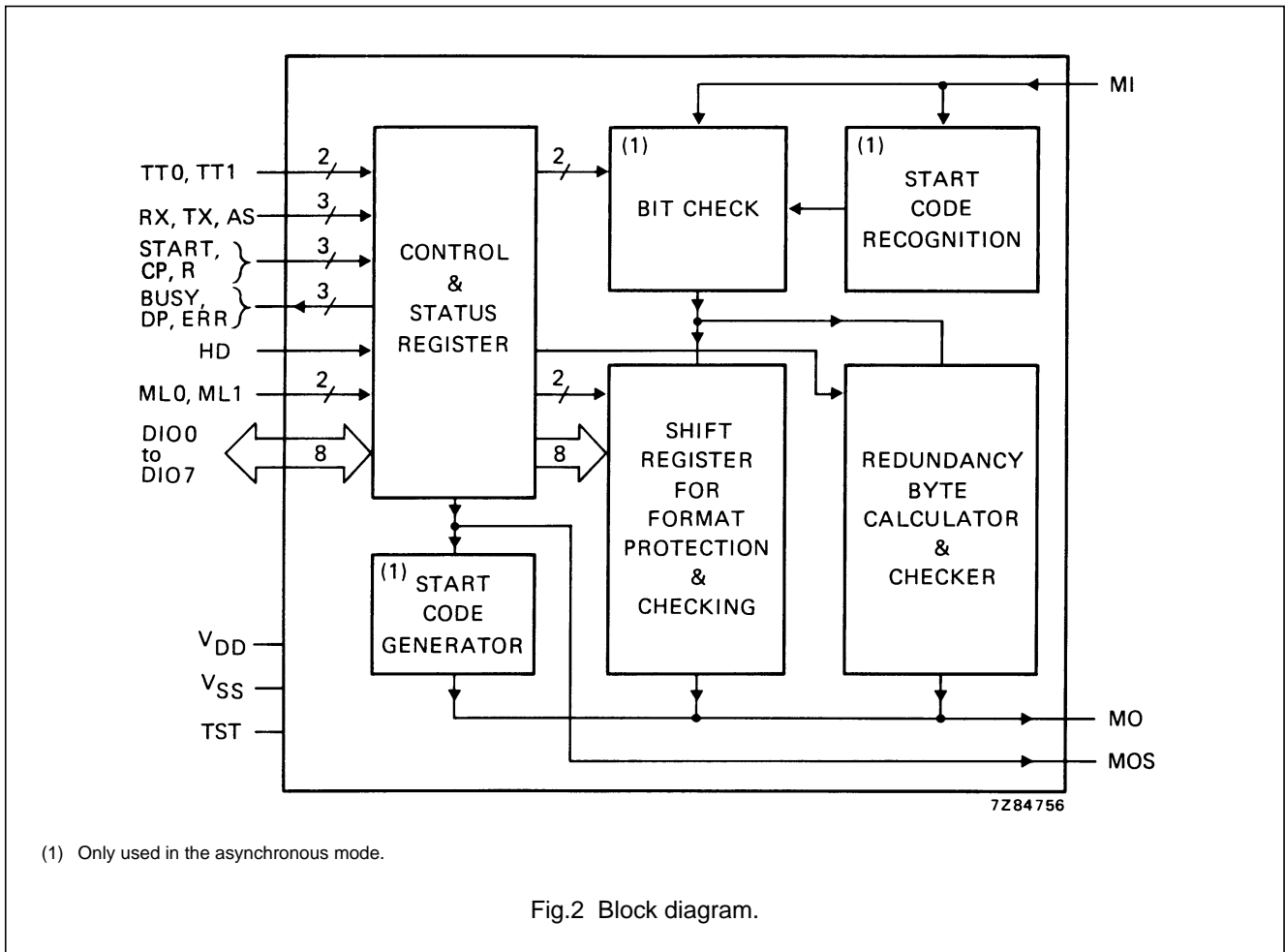

Transceiver for serial data communication

HEF4755V
LSI

FUNCTIONAL DESCRIPTION

General

The HEF4755V is used for protected-bit serial data communication. This protection makes it necessary to subdivide the serial data stream into data blocks called messages.

Messages

In the synchronous mode the HEF4755V will transmit or receive a message as follows:

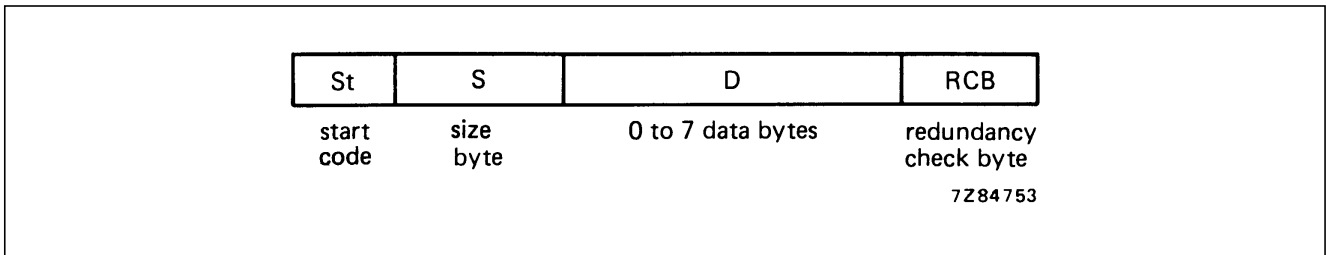

The first bit of a transmitted message is the start-bit which cannot be mis interpreted. It instructs the receiver, that information transfer has started and it defines the time-window for the following bits. The start-bit is only necessary in the asynchronous mode and it is omitted in the synchronous mode. The first byte contains the number of data bytes that will follow. This byte is checked by the receiver and if a discrepancy is found, the receiver reports a code-error. This first byte is called 'size'. The number of data bytes can also be fixed by wiring of the transmitter as well as the receiver. In this case the size byte is omitted. There is no protocol on the information of the data bytes, so the maximum number of informations per message is $2^{56} \approx 10^{17}$.

The redundancy check byte secures the data bytes against transmission errors. This byte is calculated in

parallel to the data stream and it is send as last byte by the transmitter. The receiver calculates its own redundancy byte and compares it with the received one. If there is a discrepancy, the receiver reports a code error.

Code protection

Size

The coding of the size byte is as follows:

$$\begin{array}{l}
 \text{DIO0} = \text{C} \\
 \text{DIO1} = \text{B} \\
 \text{DIO2} = \text{A} \\
 \text{DIO3} = \text{P}
 \end{array}
 \left|
 \begin{array}{l}
 n = \text{C} \cdot 2^2 + \text{B} \cdot 2^1 + \text{A} \cdot 2^0 \\
 \hline
 = \text{C} \oplus \text{B} \oplus \text{A}
 \end{array}
 \right.$$

The information is transmitted as follows:

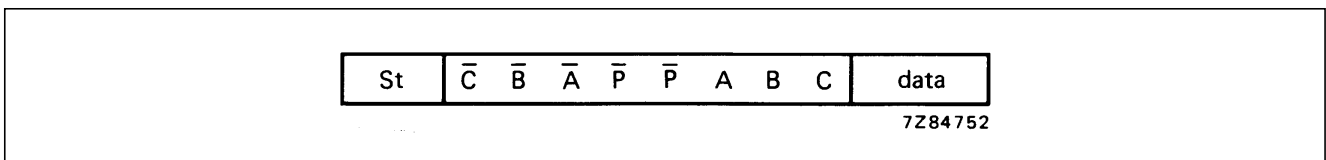

With this, a hamming distance of 4 is obtained.

Transceiver for serial data communication

HEF4755V
LSI

Redundancy byte

The redundancy byte completes the data bytes with 15 (7) bits as a code word. If only one bit in the information has changed during the transmission, the two code words will differ by at least 6 (4) bit positions. So a change of up to 5 (3) bits will always be observed, even every odd number of false bits will be recognized. The HEF4755V has a programmable redundancy bit calculator which carries out this protection (the numbers given in parentheses are valid for the alternative possibility).

If the transmission line carries extreme noise, this kind of message protection is less effective. In this case, the message is protected by checking bit-per-bit in a smaller time scale (see 'bit protection' below).

Bit protection

The HEF4755V checks every received bit within the time window defined by the start-bit. The programmed time tolerance (19%, 25%, 31% and 37%) determines that the bit protection circuit decides after 32 samples which bit is a true logic HIGH or LOW level, or an error. In the latter case, there are too many samples HIGH to obtain a LOW and, too many samples LOW to obtain a HIGH.

Transmitting

In the transmitting mode the HEF4755V uses the data pulse signal (DP, pin 23) to take 8 bits from the data bus. These parallel bits are shifted serially to the message output (MO).

Receiving

In the receiving mode the HEF4755V receives serial bits at the message input (MI). The circuit checks the message for transmission errors and, with every data pulse, 8 bits are transferred in parallel to the data bus. Every recognized error is stored and the error output is activated. The kind of error can be recognized by reading the status register over the data bus.

Asynchronous and synchronous mode

If only one transmission line is available, then the receiver waits for the start-bit, synchronizes itself on the start bit and receives all the data bits of one message. This is called the *asynchronous mode*. By using 3 transmission lines, the circuit can go to the *synchronous mode*. In this case it is possible to transmit also the clock signal (CP) and message synchronization signal (MOS) in parallel with the data bits. The start bit and the bit check are omitted. In the synchronous mode the maximum transmission speed is 32 times the maximum speed in the asynchronous mode.

In asynchronous receive mode a reset pulse is necessary between two messages. It is possible to derive this reset pulse from the busy signal by using hardware. The duration of the START-pulse at the transmitter must always be shorter than the message to be transferred. A good procedure for achieving this is to use the BUSY-signal to end the START-pulse. The recovery time between two messages must be at least two bit periods. During this time, the line must remain stable to prevent generation of an error. This must be ensured with external hardware/software.

In the synchronous receive mode, the duration of the START-pulse at the transmitter must always be shorter than the message to be transferred. A good procedure for achieving this is to use the BUSY-signal to end the START-pulse. A continuous START-signal will cause malfunction. The recovery time between two messages must be at least one bit period. During this time, the message line must remain stable. A good way to achieve this is to use the trailing-edge of the BUSY-signal to generate a START-signal. In practice, if data is delivered to the transmitter fast enough, START can be $\overline{\text{BUSY}}$. If the lines have different delays, the message line should have the longest delay. If it is not certain which line has the longest delay it is possible to phase-shift the clock signal of the receiver by inverting it. This is only possible with point-to-point lines.

Transceiver for serial data communication

HEF4755V
LSI

DC CHARACTERISTICS

 $V_{SS} = 0\text{ V}$; $T_{amb} = -40\text{ to }+85\text{ }^{\circ}\text{C}$; unless otherwise specified

PARAMETER	V_{DD} V	SYMBOL	MIN.	TYP.	MAX.	UNIT	CONDITIONS
Outputs							
Output voltage LOW	4,75 to 12,6	V_{OL}	–	–	0,4	V	$I_{OL} = 1,8\text{ mA}$
	4,75	V_{OL}	–	–	0,4	V	$I_{OL} = 2,3\text{ mA}$ $T_{amb} = 25\text{ }^{\circ}\text{C}$
Output voltage HIGH	4,75 to 12,6	V_{OH}	$V_{DD}-1$	–	–	V	$-I_{OH} = 1,1\text{ mA}$
	4,75	V_{OH}	$V_{DD}-1$	–	–	V	$-I_{OH} = 1,4\text{ mA}$ $T_{amb} = 25\text{ }^{\circ}\text{C}$
Inputs/outputs							
<i>As outputs</i>							
Output voltage LOW	4,75 to 12,6	V_{OL}	–	–	0,4	V	$I_{OL} = 1,8\text{ mA}$
	4,75	V_{OL}	–	–	0,4	V	$I_{OL} = 2,3\text{ mA}$ $T_{amb} = 25\text{ }^{\circ}\text{C}$
Output voltage HIGH	4,75 to 12,6	V_{OH}	$V_{DD}-1$	–	–	V	$-I_{OH} = 1,1\text{ mA}$
	4,75	V_{OH}	$V_{DD}-1$	–	–	V	$-I_{OH} = 1,4\text{ mA}$ $T_{amb} = 25\text{ }^{\circ}\text{C}$
Output leakage current HIGH	12,6	I_{OZH}	–	–	20	μA	$V_{OH} = 12,6\text{ V}$
	12,6	I_{OZH}	–	–	5	μA	$V_{OH} = 12,6\text{ V}$ $T_{amb} = 25\text{ }^{\circ}\text{C}$
LOW		$-I_{OZL}$	–	–	20	μA	$V_{OL} = 0\text{ V}$
		$-I_{OZL}$	–	–	5	μA	$V_{OL} = 0\text{ V}$ $T_{amb} = 25\text{ }^{\circ}\text{C}$
<i>As inputs</i>							
Input voltage LOW	4,75 to 12,6	V_{IL}	0	–	$0,3 V_{DD}$	V	
Input voltage HIGH	4,75 to 12,6	V_{IH}	$0,7 V_{DD}$	–	V_{DD}	V	

Transceiver for serial data communication

HEF4755V
LSI**AC CHARACTERISTICS** $V_{SS} = 0\text{ V}$; $T_{amb} = -40\text{ to }+85\text{ }^{\circ}\text{C}$; unless otherwise specified

PARAMETER	V_{DD} V	SYMBOL	MIN.	TYP.	MAX.	UNIT	CONDITIONS
Asynchronous mode							AS at V_{DD}
Clock pulse width LOW	5	t_{WCPL}	500			ns	
	10		125			ns	
HIGH	5	t_{WCPH}	500			ns	
	10		125			ns	
START pulse width HIGH	5	t_{WSH}	0,9			μs	
	10		0,22			μs	
Set-up time $D_n \rightarrow CP$	5	t_{su}	1,4			μs	
	10		0,35			μs	
Hold time $CP \rightarrow D_n$	5	t_{hold}	0			μs	
	10		0			μs	
Reset (R) pulse width HIGH	5	t_{WRH}	1			μs	
	10		0,25			μs	
Synchronous mode							AS at V_{SS}
Clock pulse width LOW	5	t_{WCPL}	625			ns	
	10		150			ns	
HIGH	5	t_{WCPH}	625			ns	
	10		150			ns	
Set-up time START \rightarrow CP	5	t_{su}	0,6			μs	
	10		0,15			μs	
Hold time CP \rightarrow START	5	t_{hold}	300			ns	
	10		75			ns	
Set-up time $D_n \rightarrow CP$	5	t_{su}	600			ns	
	10		150			ns	
Hold time CP $\rightarrow D_n$	5	t_{hold}	0			ns	
	10		0			ns	
Reset (R) pulse width HIGH	5	t_{WRH}	1			μs	
	10		0,25			μs	

Note

1. Measured between output voltage levels of 0,8 V and 2 V.

Transceiver for serial data communication

HEF4755V
LSI

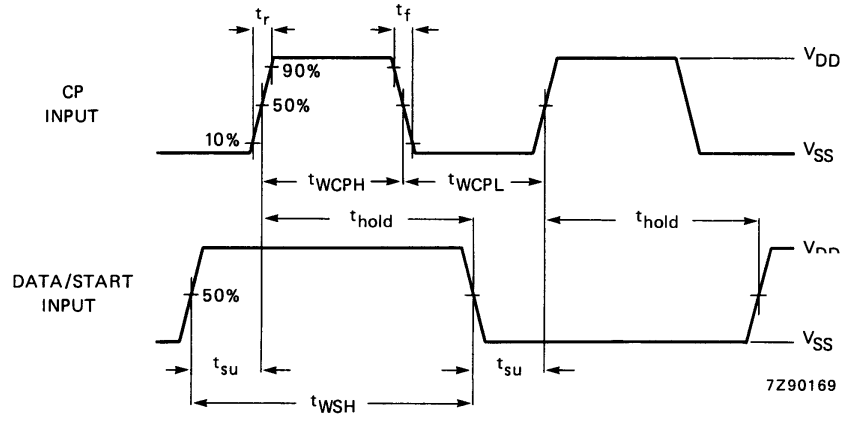

Fig.6 Waveforms showing the clock, data and start timing.

Transceiver for serial data communication

HEF4755V
LSI

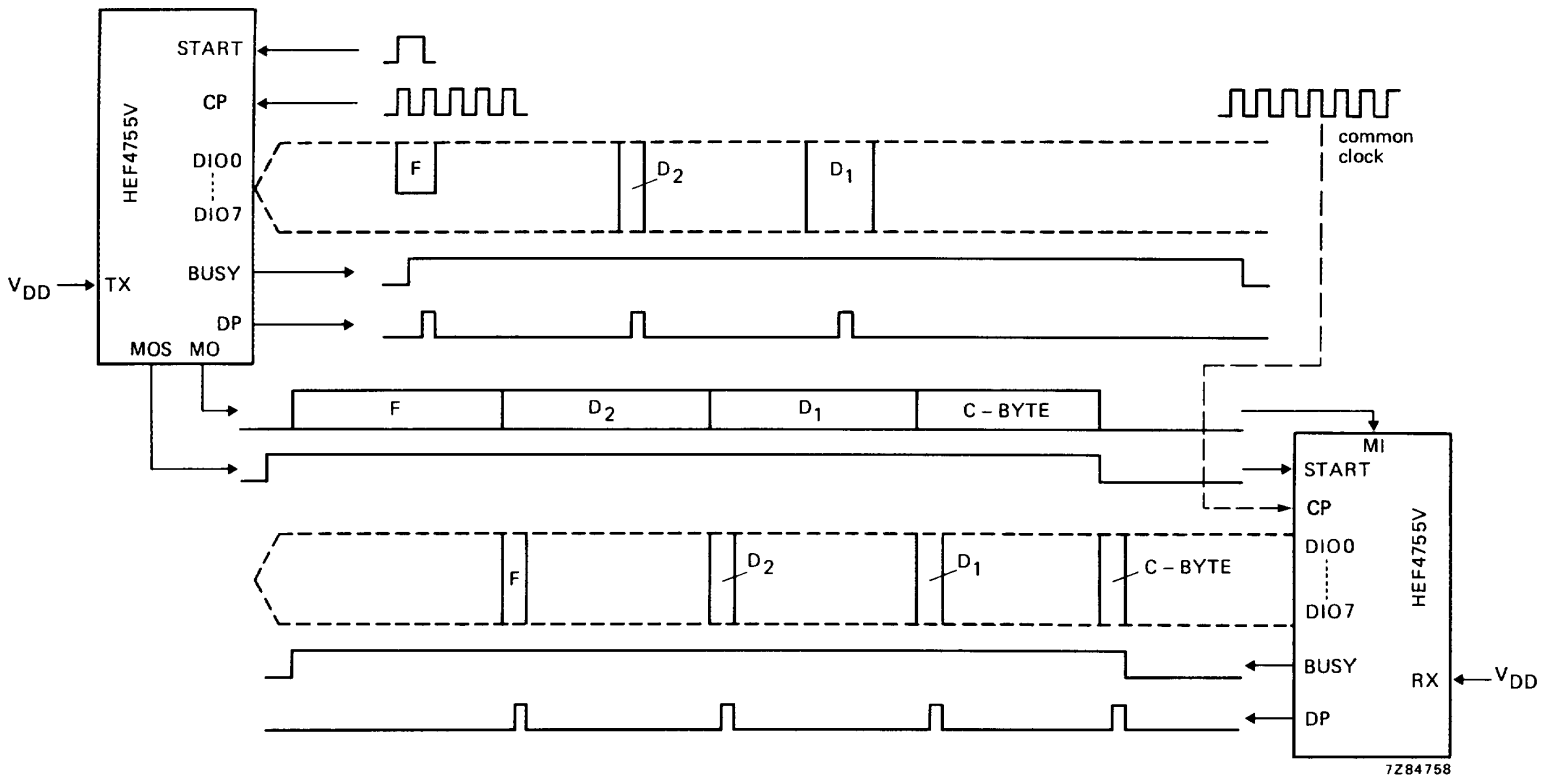

Fig.7 Function/timing diagram when using the HEF4755V in the asynchronous mode where the byte number per message is variable and the hamming distance is 4.

Transceiver for serial data communication

HEF4755V
LSI

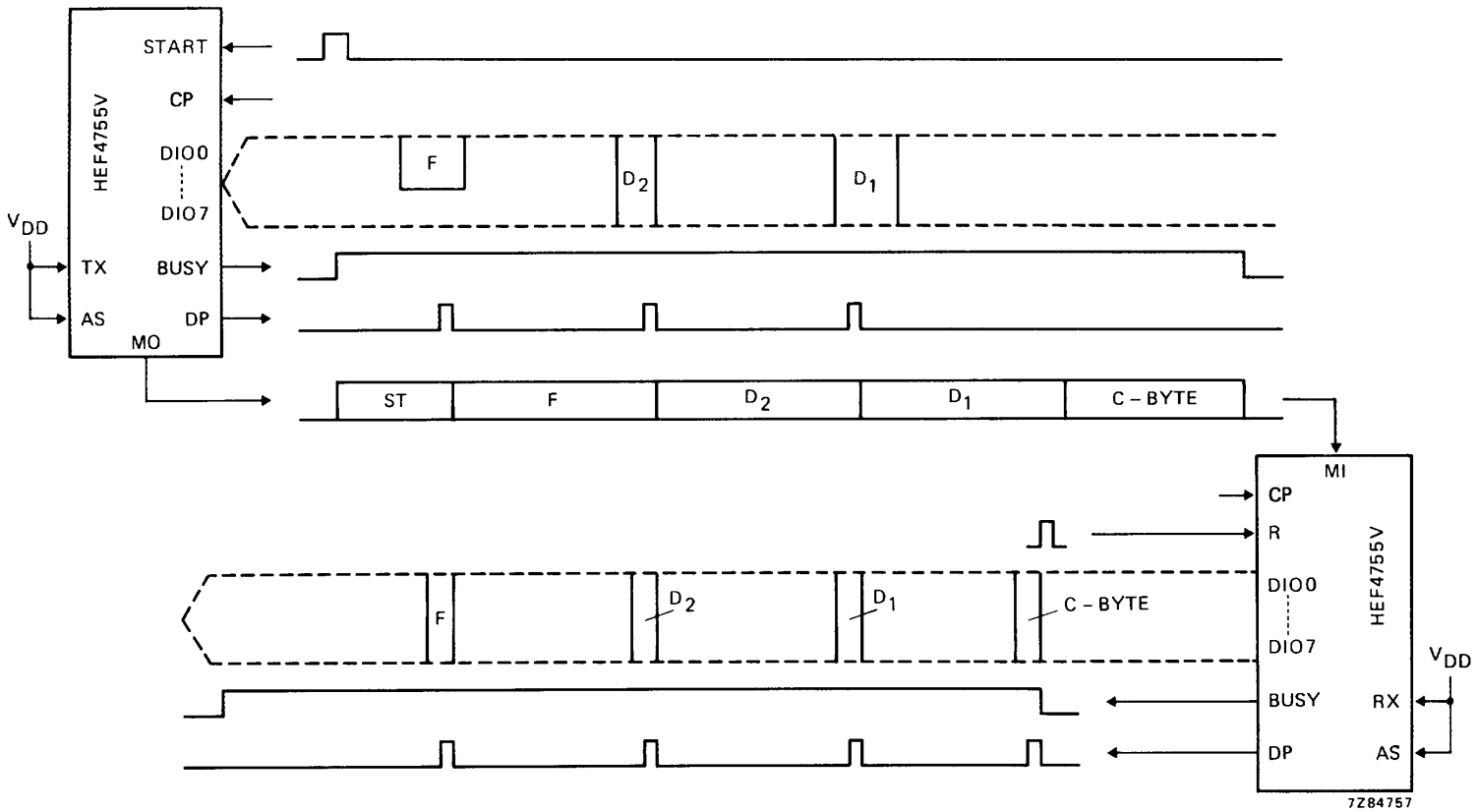

Fig.8 Function/timing diagram when using the HEF4755V in the asynchronous mode where the byte number per message is variable and the hamming distance is 4.