

DESCRIPTION

The HI-8105 & HI-8106 are silicon gate CMOS devices designed for 'glue' logic applications. They are simple 16 stage dividers with programmable division. The HI-8105 has a one pin oscillator while the HI-8106 receives a clock input. The one pin oscillator frequency is set by a resistor to VDD and the capacitance to AC ground at the pin.

The wafer processing enables operation to 1 volt guaranteed. The chip is designed for low power performance. As a result the maximum output frequency is 5 MHz while the internal logic will run considerably higher.

A companion version, HI-8107, features a crystal oscillator circuit and a 8 stage programmable divider.

PIN CONFIGURATION

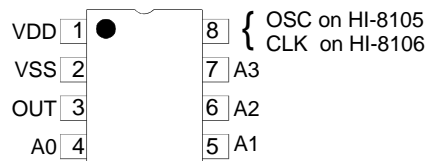

SUPPLY VOLTAGES

VDD = 1V to 5V

FUNCTION TABLE

A3	A2	A1	A0	OUT
0	0	0	0	DIV by 2
0	0	0	1	4
0	0	1	0	8
0	0	1	1	16
0	1	0	0	32
0	1	0	1	64
0	1	1	0	128
0	1	1	1	256
1	0	0	0	512
1	0	0	1	1024
1	0	1	0	2048
1	0	1	1	4096
1	1	0	0	8192
1	1	0	1	16384
1	1	1	0	32768
1	1	1	1	65536

PIN DESCRIPTION TABLE

PIN	SYMBOL	FUNCTION	DESCRIPTION
1	VDD	SUPPLY	POSITIVE SUPPLY, 1V TO 5V
2	VSS	SUPPLY	GROUND
3	OUT	LOGIC OUTPUT	CMOS
4	A0	LOGIC INPUT	CMOS
5	A1	LOGIC INPUT	CMOS
6	A2	LOGIC INPUT	CMOS
7	A3	LOGIC INPUT	CMOS
8	OSC (8105)	INPUT/OUTPUT	RC - CONNECT TO VDD
8	CLK (8106)	LOGIC INPUT	CMOS

FEATURES

- 1V TO 5V Low Power Operation
- 5MHz Operation
- 30MHz division at 5V
- 5MHz division at 1V
- 8 Pin SOIC package

FUNCTIONAL DESCRIPTION

The HI8105 and HI-8106 are 16 stage serial counters. Each stage's Q is input to a 1 of 16 decoder. A 4 bit code at pins 4 through 7 selects which stage is routed to the output at pin 3. The counter clocks on the negative transition of pin 8.

Figure 1 shows the oscillator circuit of the HI-8105. The charging time is controlled by a delay circuit and the hysteresis window. The window is typically 0.6V wide at VDD=5.0V.

Figure 2 shows the bonding option which omits the N device pulldown and thereby allows the simple clock input of the HI-8106.

APPLICATION INFORMATION

The HI-8105 oscillator frequency is set by selecting a resistor and capacitor to apply at pin 8. Typical parameters at room temperature are:

OSCILLATOR FREQUENCY DATA

Ro	Co = 100pF		Co = 1nF	
	VDD=5V	VDD=1V	VDD=5V	VDD=1V
1KΩ	7.80MHz	-	2.12MHz	-
3KΩ	4.22MHz	914KHz	1.10MHz	231KHz
10KΩ	1.46MHz	464KHz	359KHz	100KHz
100KΩ	165KHz	64KHz	39.6KHz	12KHz

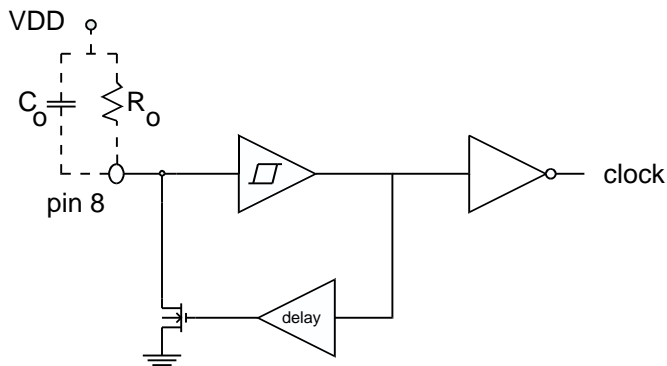

FIGURE 1 - HI-8105 Oscillator

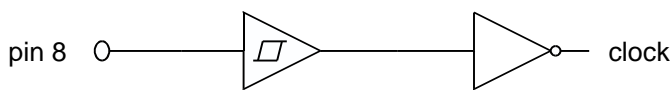

FIGURE 2 - HI-8106 Clock Input

ORDERING INFORMATION

PART NUMBER	PACKAGE DESCRIPTION	TEMPERATURE RANGE	FLOW	BURN IN	LEAD FINISH
HI-8105PDI	8 PIN PLASTIC DIP	-40°C TO +85°C	I	NO	SOLDER
HI-8105PDT	8 PIN PLASTIC DIP	-55°C TO +125°C	T	NO	SOLDER
HI-8105PSI	8 PIN PLASTIC NARROW BODY SOIC	-40°C TO +85°C	I	NO	SOLDER
HI-8105PST	8 PIN PLASTIC NARROW BODY SOIC	-55°C TO +125°C	T	NO	SOLDER
HI-8105CDI	8 PIN CERAMIC SIDE BRAZED DIP	-40°C TO +85°C	I	NO	GOLD
HI-8105CDT	8 PIN CERAMIC SIDE BRAZED DIP	-55°C TO +125°C	T	NO	GOLD
HI-8105CDM	8 PIN CERAMIC SIDE BRAZED DIP	-55°C TO +125°C	M	YES	SOLDER
HI-8105CRI	8 PIN CERDIP	-40°C TO +85°C	I	NO	SOLDER
HI-8105CRT	8 PIN CERDIP	-55°C TO +125°C	T	NO	SOLDER
HI-8105CRM	8 PIN CERDIP	-55°C TO +125°C	M	YES	SOLDER

Note: The HI-8106 is available in the same options

ABSOLUTE MAXIMUM RATINGS

Voltages referenced to Ground

Supply voltages VCC.....7V
DC current per input pin..... ±10mA
Power dissipation at 25°C.....500mW
Solder Temperature275°C for 10 sec
Storage Temperature.....-65°C to +150°C

RECOMMENDED OPERATING CONDITIONS

Supply Voltages VCC.....1V to 5.25V
Temperature Range Industrial Screening.....-40°C to +85°C Hi-Temp Screening.....-55°C to +125°C Military Screening.....-55°C to +125°C

NOTE: Stresses above absolute maximum ratings or outside recommended operating conditions may cause permanent damage to the device. These are stress ratings only. Operation at the limits is not recommended.

DC ELECTRICAL CHARACTERISTICS

VDD-VSS=5V and T_A=25°C unless otherwise noted

PARAMETERS	SYMBOL	TEST CONDITIONS	MIN	TYP	MAX	UNITS
operating voltage	VDD-VSS		1.0		5.0	volts
logic input voltage high low	V _{IH} V _{IL}	pins 4,5,6,7	3.5	2.5 2.5	1.5	volts volts
logic input current high low	I _{IH} I _{IL}	pins 4,5,6,7	-1.0		1.0	µA µA
logic output drive current one zero	I _{OH} I _{OL}	pins 3 Vout=3.5V Vout=0.8V	1.7	-2.4 2.8	-1.6	mA mA
Current drain no load not clocking HI-8105 operating HI-8106 operating	IDD ₁ IDD ₂ IDD ₃	pins 4,5,6,7 all at VSS and pin 8 = VSS Ro=1KΩ and Co=100pF clocking pin 8 at 10MHz		0.5 0.6	1.0 1.0	µA mA mA
Current drain no load at 1.0 V HI-8105	IDD ₄	pins 4,5,6,7 all at VSS and Ro=10KΩ and Co=100pF		38	70	µA

8-PIN PLASTIC DIP

Package Type: 8P

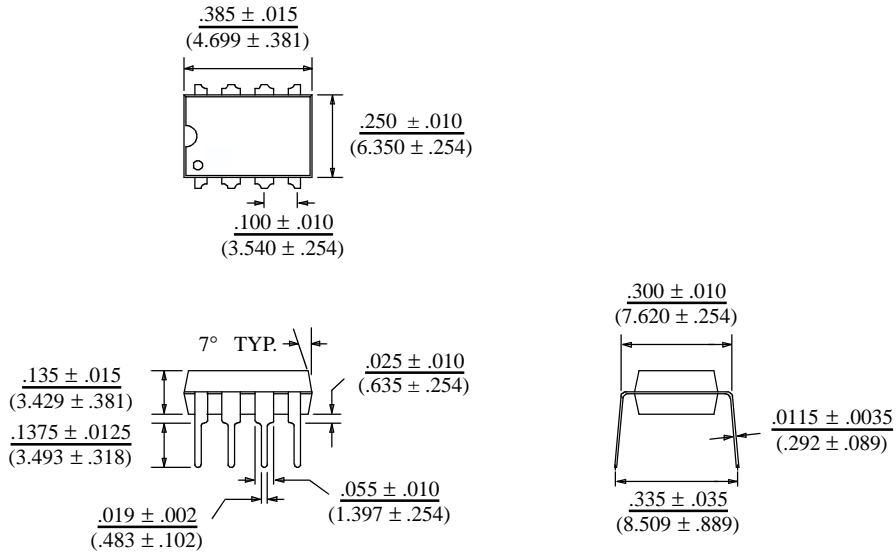

8-PIN PLASTIC SMALL OUTLINE (SOIC) - NB
(Narrow Body)

Package Type: 8HN

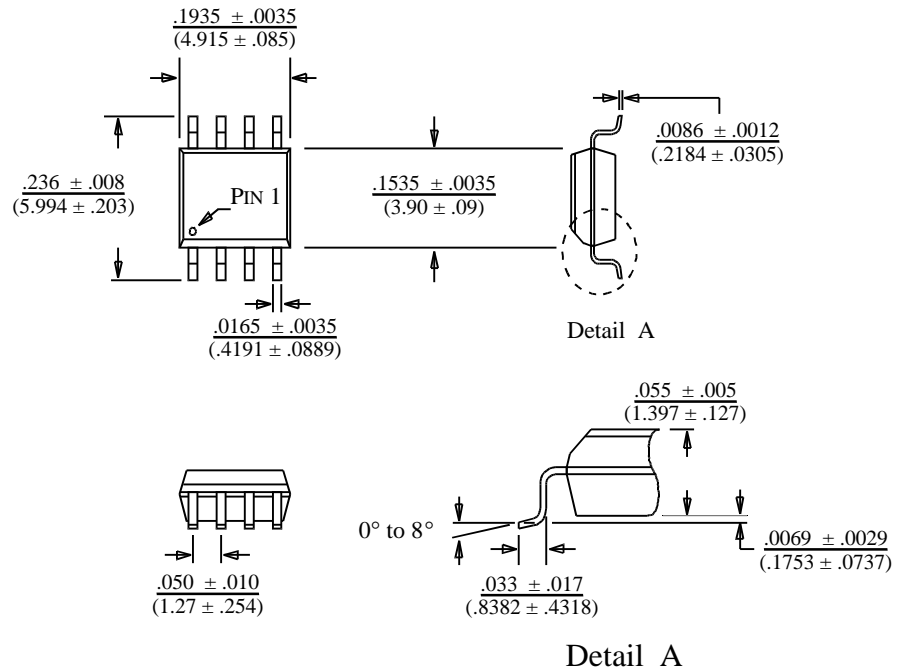

8-PIN CERAMIC SIDE-BRAZED DIP

Package Type: 8C

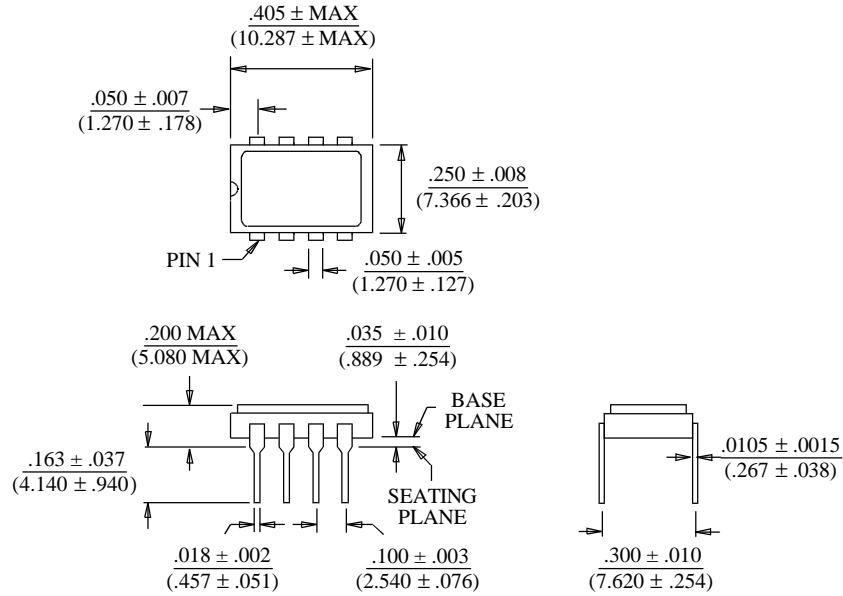

8-PIN CERDIP

Package Type: 8D

