

Switchmode Pulse Width Modulation Control Circuit

The PJ494 incorporates on a single monolithic chip all the functions required in the construction of a pulse-width-modulation control circuit. Designed primarily for power supply control, these devices offer the systems engineer the flexibility to tailor the power supply control circuitry to his application.

The PJ494 contains an error amplifier, an on-chip adjustable oscillator, a dead-time control comparator, pulse-steering control flip-flop, a 5-volt, 5% precision regulator, and output-control circuits. The error amplifier exhibits a common-mode voltage from -0.3 volts to  $V_{cc} - 2$  volts. The dead-time control comparator has a fixed offset that provides

approximately 5% dead time when externally altered. The on-chip oscillatory be bypassed by terminating  $R_T$  (pin 6) to the reference output and providing a sawtooth input to  $C_T$  (PIN 5), or it may be used to drive the common circuits in synchronous multiple-rail power supplies. The uncommitted output transistor provide either common-emitter or emitter-follower output capability. Each device provides for push-pull or single-ended output operation, which may be selected through the output-control function. The architecture of these devices prohibits the possibility of either output being pulsed twice during push-pull operation.

**FEATURES**

- Complete PWM Power Control Circuitry
- Uncommitted Outputs for 200mA Sink or Source Current
- Output Control Selects Single-Ended or Push -Pull Operation
- Internal Circuitry Prohibits Double Pulse at Either Output
- Variable Dead-Time Provides Control over Total Range
- Internal Regulator Provides a Stable 5-V Reference Supply, 5%

**ORDERING INFORMATION**

Device	Operating Temperature (Ambient)	Package
PJ494CD	-20°C to +85°C	DIP-16
PJ494CS		SOP-16

DIP-16

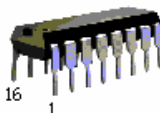

SOP-16

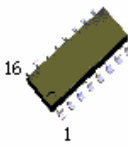

Pin 1. Noninv Input	} Error Amp1
2. Inv Input	
3. Feedback	4. Dead-Time Control
5. $C_T$	6. $R_T$ 7. Gnd
8. C1	9. E1    10. E2
11. C2	12. $V_{cc}$
13. Output Control	14. Ref Out
15. Inv Input	} Error Amp2
16. Noninv Input	

**ABSOLUTE MAXIMUM RATINGS OVER OPERATING FREE-AIR TEMPERATURE RANGE**

(unless otherwise noted)

Rating	Symbol	Value	Unit
Supply voltage	$V_{cc}$	41	V
Amplifier input voltage	$V_i$	$V_{cc} + 0.3$	
Collector output voltage	$V_o$	41	
Collector output current		250	mA
Operating free-air temperature range		-20 to 85	°C
Storage temperature range	$T_{stg}$	-25 to 125	
Operating Junction Temperature	$T_J$	125	
Lead temperature 1,6mm from case for 10 seconds		260	
Power Dissipation @ $T_A \leq 45^\circ C$	$P_D$	1000	

Switchmode Pulse Width Modulation Control Circuit

**RECOMMENDED OPERATING CONDITIONS**

Parameter	Symbol	Min	Max	Unit
Supply voltage	V <sub>cc</sub>	7	40	V
Amplifier input voltage	V <sub>i</sub>	-0.3	V <sub>cc</sub> -2	
Collector output voltage	V <sub>o</sub>		40	
Collector output current(each transistor)			200	mA
Current into feedback terminal			0.3	
Timing capacitor	C <sub>T</sub>	0.47	10000	nF
Timing resistor	R <sub>T</sub>	1.8	500	KΩ
Oscillator frequency		1	300	KHz
Operating free-air temperature	T <sub>A</sub>	0	70	°C

**ELECTRICAL CHARACTERISTICS OVER RECOMMENDED OPERATING FREE-AIR TEMPERATURE**

V<sub>cc</sub>=15V, f=10KHz (unless otherwise noted).

**REFERENCE SECTION**

Parameter	Test Conditions*	Value			Unit
		Min	Typ	Max	
Output voltage(V <sub>ref</sub> )	I <sub>o</sub> =1mA	4.75	5	5.25	V
Line regulation	V <sub>cc</sub> =7V to 40V	--	2.0	25	mV
Load regulation	I <sub>o</sub> =1mA to 10mA	--	3.0	15	
Output voltage change with temperature	ΔT <sub>A</sub> =MIN to MAX	--	0.2	1	%
Short-circuit output current***	V <sub>ref</sub> =0	15	35	75	mA

**OSCILLATOR SECTION**

Parameter	Test Conditions*	Value			Unit
		Min	Typ	Max	
Frequency	C <sub>T</sub> =0.001μF, R <sub>T</sub> =30KΩ	--	40	--	KHz
Standard deviation of frequency****	C <sub>T</sub> =0.001μF, R <sub>T</sub> =30KΩ	--	3.0	--	%
Frequency change with voltage	V <sub>cc</sub> =7V to 40V, T <sub>A</sub> =25°C	--	0.1	--	
Frequency change with temperature***	C <sub>T</sub> =0.001μF, R <sub>T</sub> =30KΩ ΔT <sub>A</sub> =MIN to MAX	--	--	12	

**ERROR AMPLIFIER SECTION**

Parameter	Test Conditions*	Value			Unit
		Min	Typ**	Max	
Input offset voltage	V <sub>o</sub> =(pin 3)=2.5V	--	2.0	10	mA
Input offset current	V <sub>o</sub> =(pin 3)=2.5V	--	5.0	250	nA
Input bias current	V <sub>o</sub> =(pin 3)=2.5V	--	-0.1	-1.0	μA
Common-mode input voltage range	V <sub>cc</sub> =7V to 40V	-0.3 to V <sub>cc</sub> -2			V
Open-loop voltage amplification	ΔV <sub>o</sub> =3V, R <sub>L</sub> =2KΩ, V <sub>o</sub> =0.5 to 3.5V	70	95	--	dB
Unity-gain bandwidth	R <sub>L</sub> =2KΩ, V <sub>o</sub> =0.5 to 3.5V	--	800	--	KHz
Common-mode rejection ratio	ΔV <sub>o</sub> =40V, T <sub>A</sub> =25°C	65	90	--	dB
Power Supplu Rejection Ratio	ΔV <sub>cc</sub> =33V, V <sub>o</sub> =2.5V, R <sub>L</sub> =2KΩ	--	100	--	dB
Output sink current (pin 3)	V <sub>ID</sub> =-15mV to -5V, V <sub>(PIN3)</sub> =0.7V	0.3	0.7	--	mA
Output source current (pin 3)	V <sub>ID</sub> =15mV to 5V, V <sub>(PIN3)</sub> =3.5V	2.0	-4.0	--	mA

**OUTPUT SECTION**

Parameter	Test Conditions	Value			Unit
		Min	Typ	Max	
Collector off-state current	V <sub>CE</sub> =40V, V <sub>CC</sub> =40V	--	2.0	100	μA
Emitter off-state current	V <sub>cc</sub> =V <sub>c</sub> =40V, V <sub>E</sub> =0	--	--	-100	
Collector-emitter saturation voltage	Common-emitter	V <sub>E</sub> =0, I <sub>c</sub> =200mA	--	1.1	V
	Emitter-follower	V <sub>c</sub> =15V, I <sub>E</sub> =-200mA	--	1.5	
Output control input current	V <sub>I</sub> =V <sub>ref</sub>	--	--	3.5	mA

Switchmode Pulse Width Modulation Control Circuit

DEAD-TIME CONTROL SECTION Dead-time control-section (See Figure 11)

Parameter	Test Conditions	Value			Unit
		Min	Typ*	Max	
Input bias current (pin 4)	V <sub>I</sub> =0 to 5.25V	--	-2.0	-10	μA
Maximum duty cycle, each output	V <sub>I</sub> (pin 4)=0, C <sub>T</sub> =0.1μF, R <sub>T</sub> =12KΩ	--	45	50	%
Input threshold voltage(pin 4)	Zero duty cycle	--	3.0	3.3	V
	Maximum duty cycle	0	--	--	

PWM COMPARATOR SECTION (See Figure11)

Parameter	Test Conditions	Value			Unit
		Min	Typ*	Max	
Input threshold voltage (pin 3)	Zero duty cycle	--	4.0	4.5	V
Input sink current (pin 3)	V(pin 3)=0.7V	0.3	0.7	--	mA

TOTAL DEVICE

Parameter	Test Conditions	Value			Unit	
		Min	Typ*	Max		
Standby supply current	Pin 6 at Vref, all other inputs and outputs open	Vcc=15V	--	6.0	10	mA
		Vcc=40V	--	9.0	15	
Average supply current	V <sub>I</sub> (PIN4)=2V, See Figure 1	--	7.5	--		

SWITCHING CHARACTERISTICS, T<sub>A</sub>=25°C

Parameter	Test Conditions	Value			Unit
		Min	Typ*	Max	
Output voltage rise time	Common-emitter configuration, See Figure 3	--	100	200	ns
Output voltage fall time		--	25	100	
Output voltage rise time	Emitter-follower configuration, See Figure 4	--	100	200	
Output voltage fall time		--	40	100	

UNDERVOLTAGE LOCKOUT SECTION

Parameter	Test Conditions	Value			Unit
		Min	Typ*	Max	
Turn-on Threshold	Vcc increasing Iref=1.0mA	5.5	6.43	7.0	V

- All typical value except for temperature coefficient are at T<sub>A</sub>=25°C
- For conditions shown as MIN or MAX, use the appropriate value specified under recommended operating conditions.
- All typical values except for parameter changes with temperature are at T<sub>A</sub>=25°C
- Duration of the short-circuit should not exceed one second
- Standard deviation is a measure of the statistical distribution about the mean as derived from the formula

$$\sigma = \left[ \sum_{n=1}^N \frac{(x_n - \bar{x})^2}{N - 1} \right]^{1/2}$$

- Temperature coefficient of timing capacitor and timing resistor not taken into account

Switchmode Pulse Width Modulation Control Circuit

FUNCTION BLOCK DIAGRAM

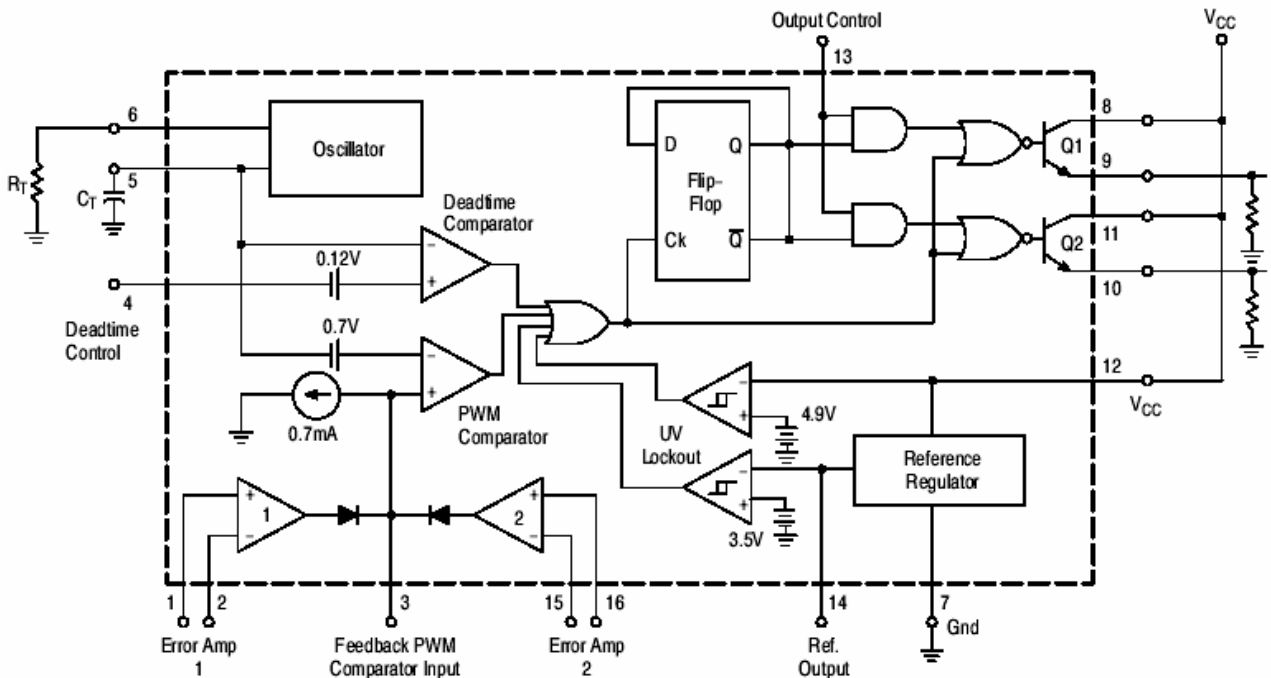

This device contained 46 active transistors  
**Figure 1. Representative Block Diagram**

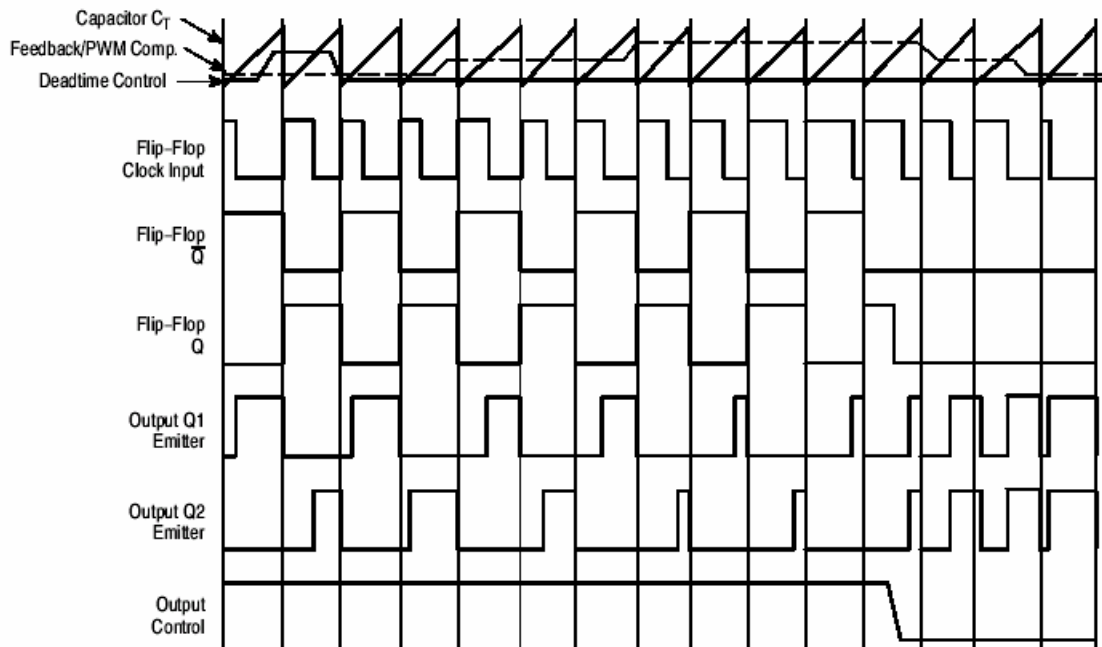

**Figure 2. Timing Diagram**

Switchmode Pulse Width Modulation Control Circuit

APPLICATIONS INFORMATION

Description

The PJ494 is a fixed-frequency pulse width modulation control circuit, incorporating the primary building blocks required for the control of a switching power supply. (See Figure 1.) An internal-linear sawtooth oscillator is frequency-programmable by two external components,  $R_T$  and  $C_T$ . The approximate oscillator frequency is determined by:

$$f_{osc} \approx \frac{1.1}{R_T \cdot C_T} \quad \dots\dots\dots \text{For more information refer to Figure 3.}$$

Output pulse width modulation is accomplished by comparison of the positive sawtooth waveform across capacitor  $C_T$  to either of two control signals. The NOR gates, which drive output transistors Q1 and Q2, are enabled only when the flip-flop clock-input line is in its low state. This happens only during that portion of time when the sawtooth voltage is greater than the control signals. Therefore, an increase in control-signal amplitude causes a corresponding linear decrease of output pulse width. (Refer to the Timing Diagram shown in Figure 2.)

The control signals are external inputs that can be fed into the deadtime control, the error amplifier inputs, or the feedback input. The deadtime control comparator has an effective 120mV input offset which limits the minimum output deadtime to approximately the first 4% of the sawtooth-cycle time. This would result in a maximum duty cycle on a given output of 96% with the output control grounded, and 48% with it connected to the reference line. Additional deadtime may be imposed on the output by setting the deadtime-control input to a fixed voltage, ranging between 0V to 3.3V.

Functional Table

Input/Output Controls	Output Function	$\frac{f_{out}}{f_{osc}} =$
Grounded	Single-ended PWM @ Q1 and Q2	1.0
@ $V_{ref}$	Push-pull Operation	0.5

The pulse width modulator comparator provides a means for the error amplifiers to adjust the output pulse width from the maximum percent on-time, established by the deadtime control input, down to zero as the voltage at the feedback pin varies from 0.5V to 3.5V. Both error amplifiers have a common mode input range from -0.3V to  $(V_{CC} - 2V)$ , and may be used to sense power-supply output voltage and current. The error -amplifier outputs are active high and are ORed together at the noninverting input of the pulse-width modulator comparator. With this configuration, the amplifier that demands minimum output on time, dominates control of the loop.

When capacitor  $C_T$  is discharged, a positive pulse is generated on the output of the deadtime comparator, which clocks the pulse-steering flip=flop and inhibits the output transistors, Q1 and Q2. With the output-control connected to the reference line, the pulse-steering flip-flop directs the modulated pulses to each of the two output transistors alternately for push-pull operation. The output frequency is equal to half that of the oscillator. Output drive can also be taken from Q1 and Q2, when single-ended operation with a maximum on-time of less than 50% is required. This is desirable when the output transformer has a ringback winding with a catch diode used for snubbing. When higher output-drive currents are required for single-ended operation, Q1 and Q2 may be connected in parallel, and the output mode pin must be tied to ground to disable the flip-flop. The output frequency will now be equal to that of the oscillator.

The PJ494 has an internal 5.0V reference capable of sourcing up to 10mA of load current for external bias circuits. The reference has an internal accuracy of  $\pm 5.0\%$  with a typical thermal drift of less than 50mV over an operating temperature range of 0 to 70°C.

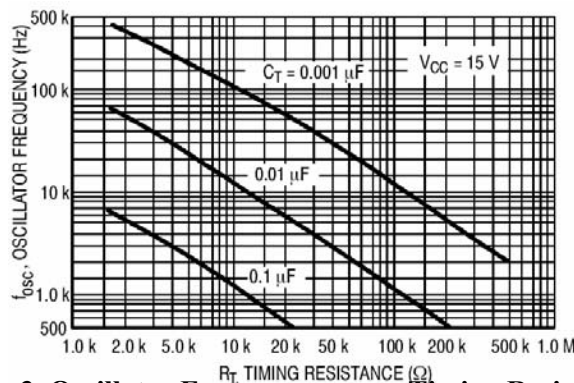

Figure 3. Oscillator Frequency versus Timing Resistance

Switchmode Pulse Width Modulation Control Circuit

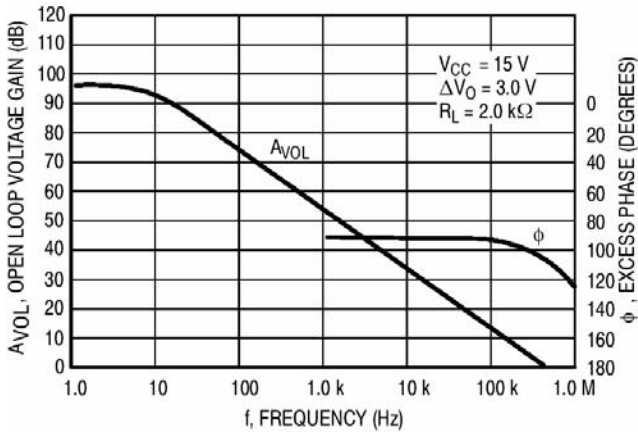

Figure 4. Open Loop Voltage Gain and Phase Versus Frequency

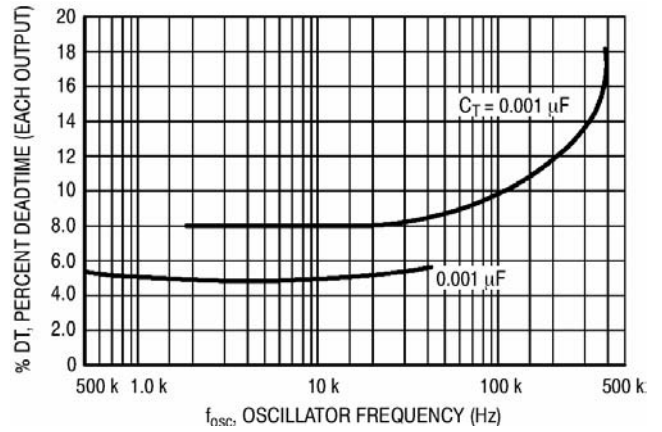

Figure 5. Percent Deadtime versus Oscillator Frequency

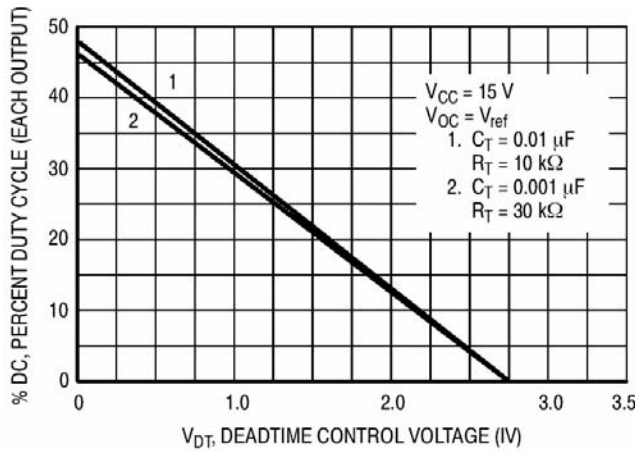

Figure 6. Percent Duty Cycle versus Deadtime Control Voltage

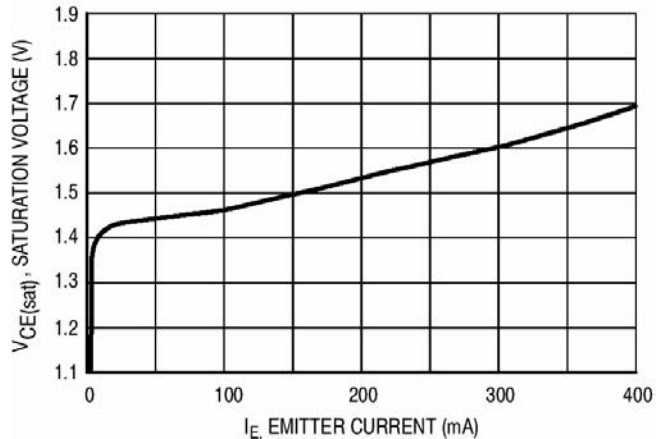

Figure 7. Emitter-Follower Configuration Output Saturation versus Emitter Current

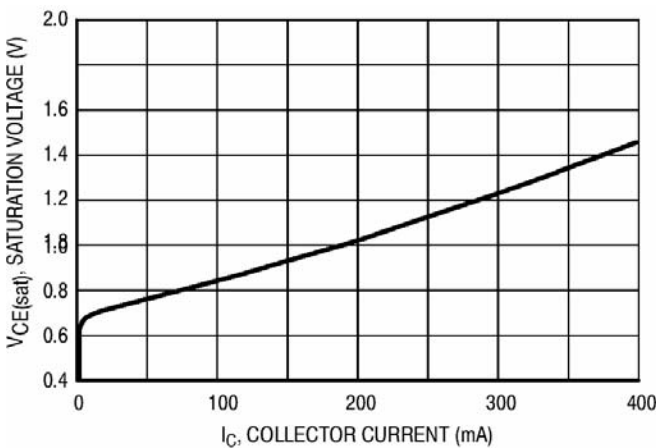

Figure 8. Common-Emitter Configuration Output Saturation Voltage versus Collector Current

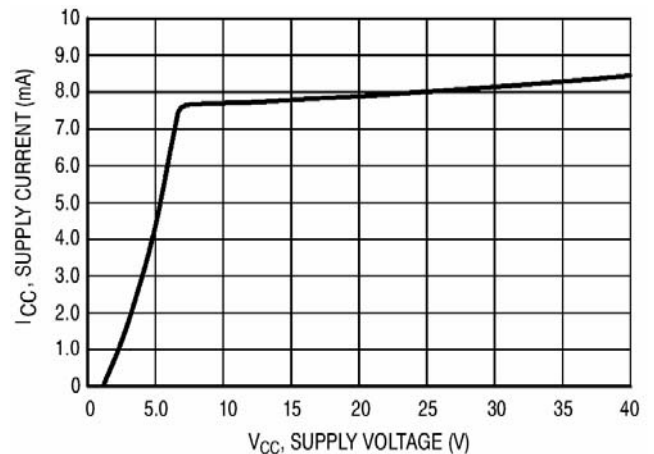

Figure 9. Standby Supply Current versus Supply Voltage

Switchmode Pulse Width Modulation Control Circuit

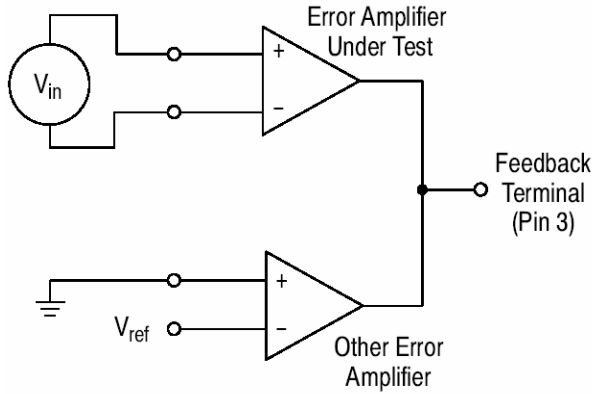

Figure 10. Error-Amplifier Characteristics

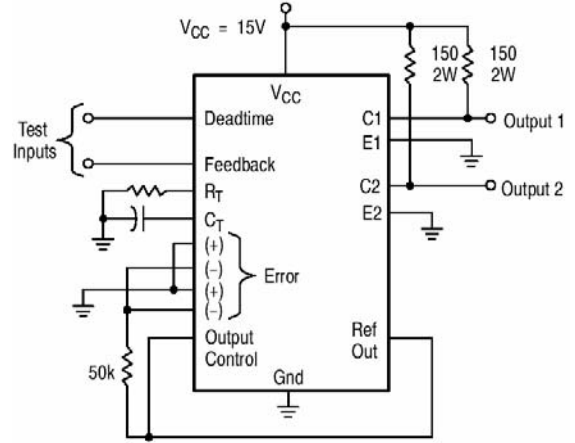

Figure 11. Deadtime and Feedback Control Circuit

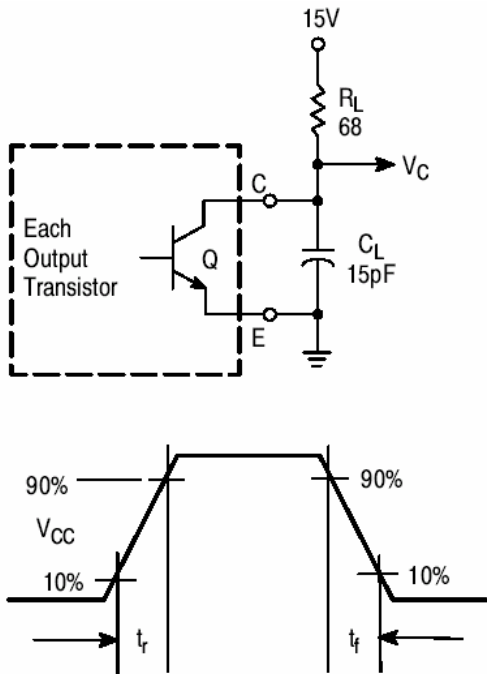

Figure 12. Common -Emitter Configuration Test Circuit and Waveform

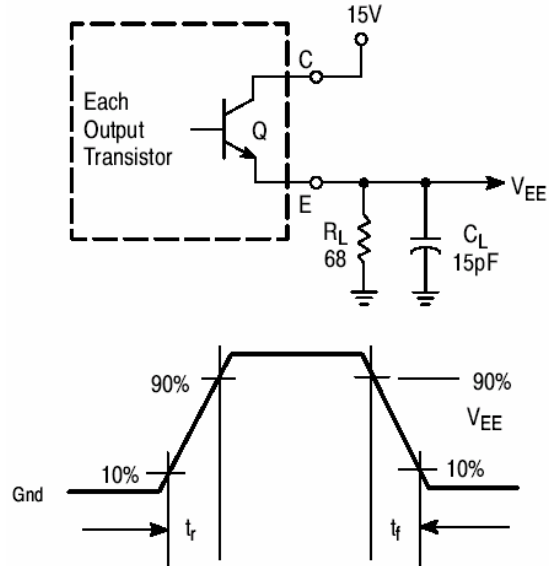

Figure 13. Emitter-Follower Configuration Test Circuit and Waveform

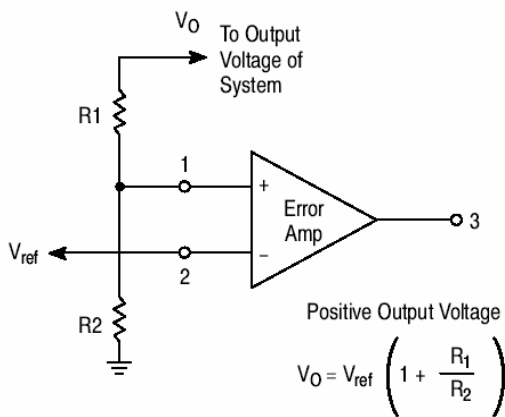
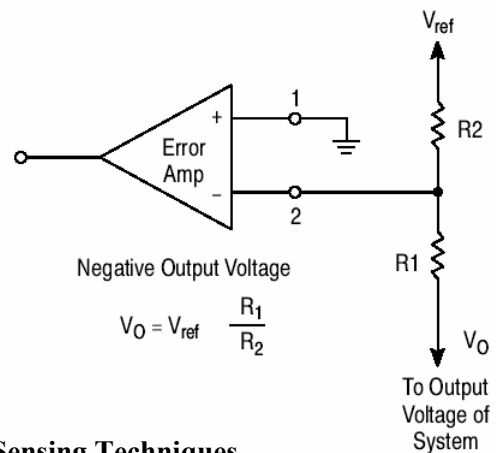
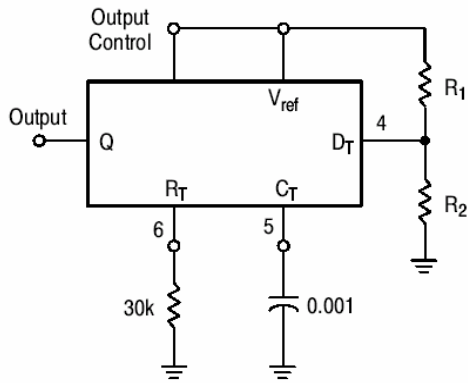

Figure 14. Error-Amplifier Sensing Techniques



Switchmode Pulse Width Modulation Control Circuit



$$\text{Max. \% on Time, each output} \approx 45 - \left( \frac{80}{1 + \frac{R1}{R2}} \right)$$

Figure 15. Deadtime Control Circuit

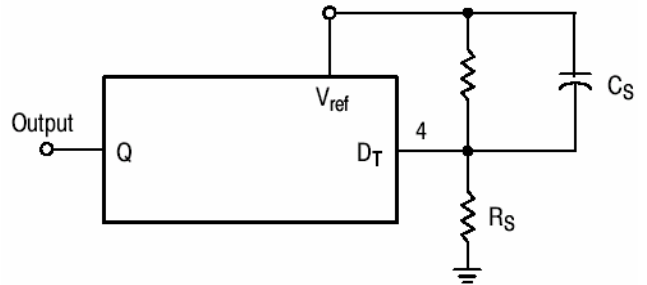

Figure 16. Soft-Start Circuit

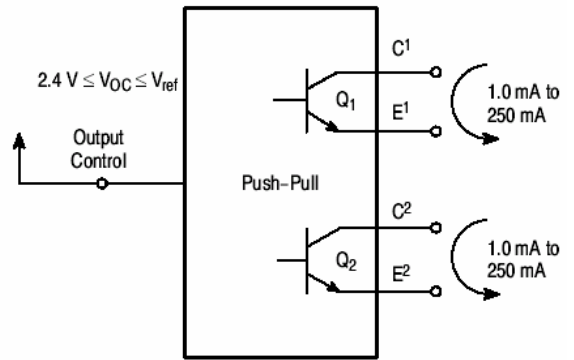
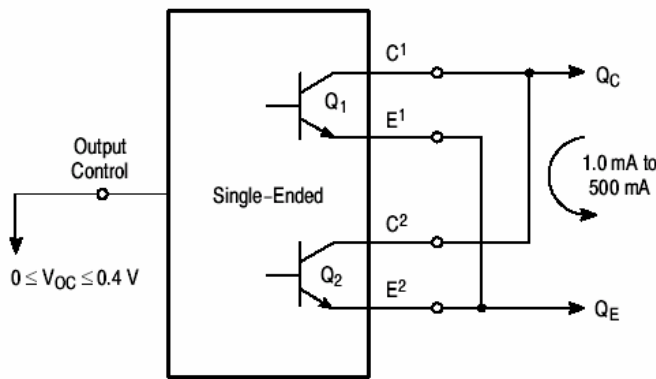

Figure 17. Output Connections for Single-Ended and Push-Pull Configurations

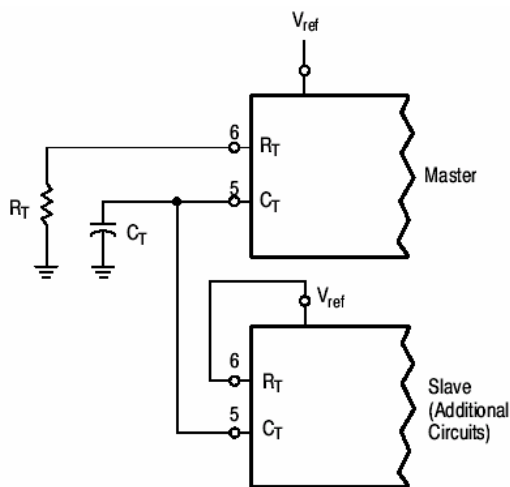

Figure 18. Slaving Two or More Control Circuit

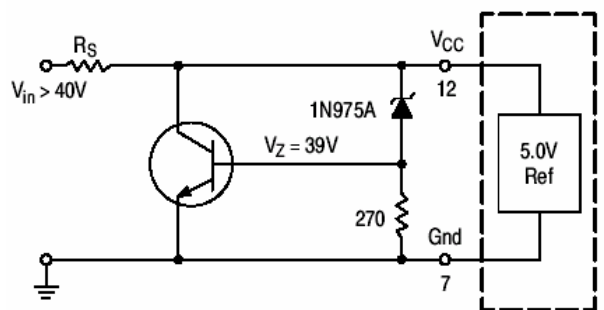

Figure 19. Operation With VIN > 40V Using External Zener



Switchmode Pulse Width Modulation Control Circuit

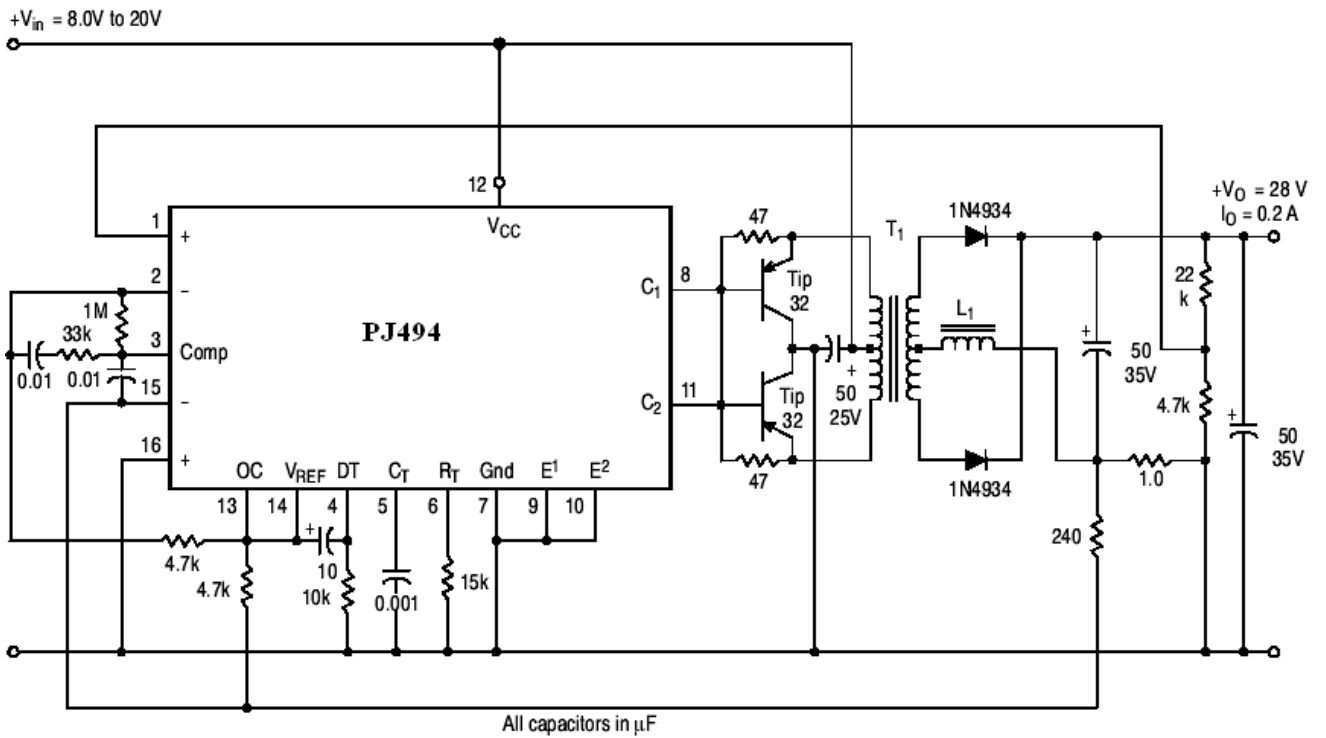

Figure 20. Pulse Width Modulated Push-Pull Converter

Test	Condition	Result
Line Regulation	$V_{IN} = 10V$ to $40V$	14mV 0.28%
Load Regulation	$V_{IN} = 28V$ , $I_o = 1.0mA$ to $10A$	3.0mV 0.06%
Output Ripple	$V_{IN} = 28V$ , $I_o = 1.0A$	65mV pp P.A.R.D
Short Circuit Current	$V_{IN} = 29V$ , $R_L = 0.1\Omega$	1.6A
Efficiency	$V_{IN} = 28V$ , $I_o = 1.0A$	71%

L1 – 3.5mH @ 0.3A

T1 – Primary : 20T C.T. #28 AWG

Secondary : 120T C.T. #36 AWG

Core : Ferroxcube 1408P-L00-3CB

Switchmode Pulse Width Modulation Control Circuit

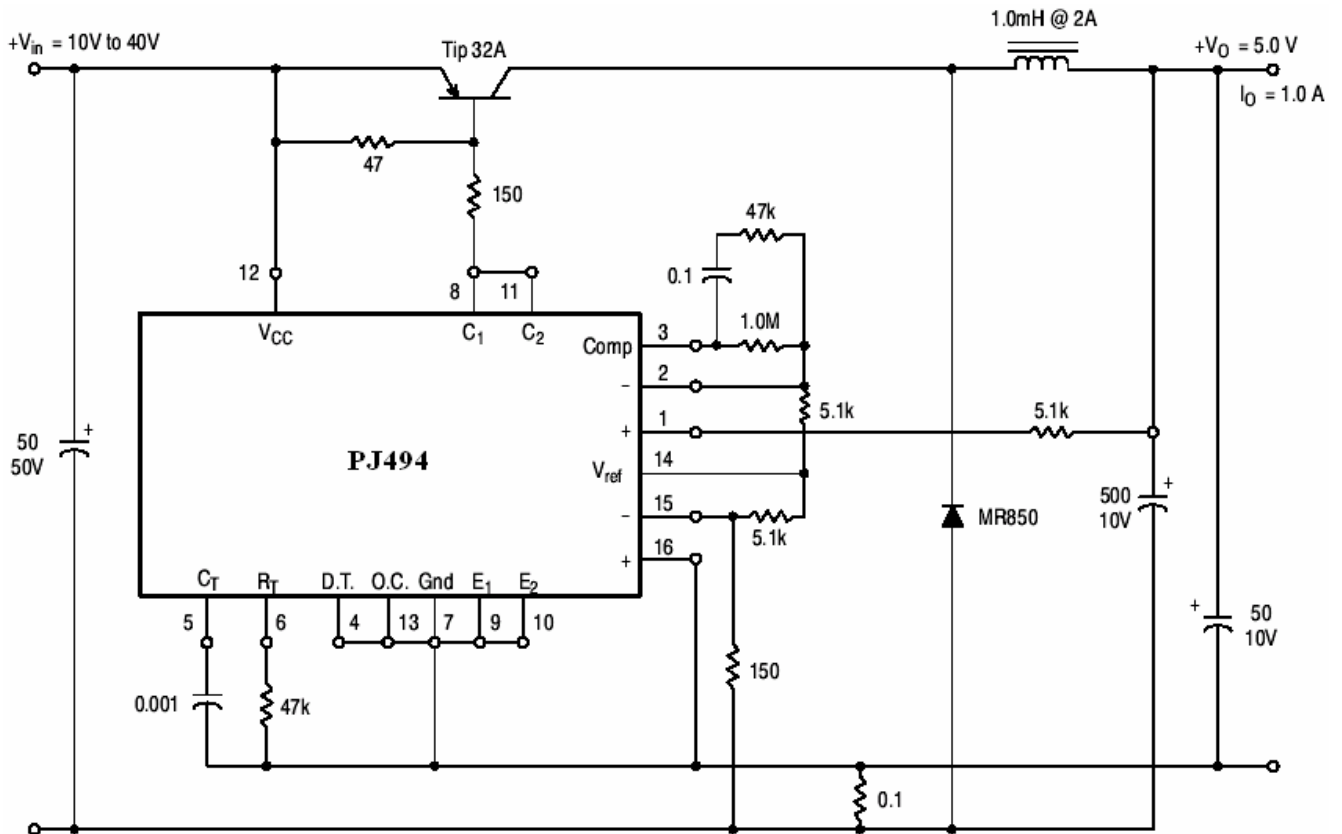
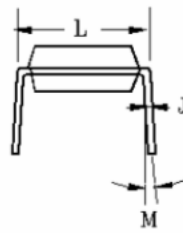
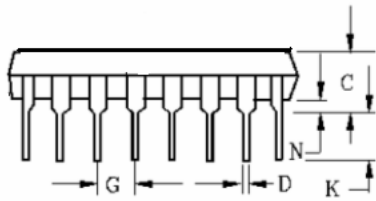
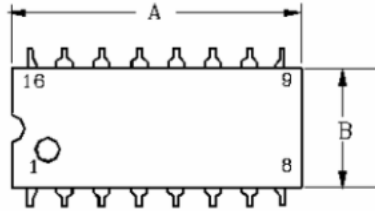

Figure 21. Pulse Width Modulated Step-Down Converter

Test	Condition	Result
Line Regulation	$V_{IN} = 8.0V$ to $40V$	3.0mV 0.01%
Load Regulation	$V_{IN} = 12.6V$ , $I_o = 0.2mA$ to $200mA$	5.0mV 0.02%
Output Ripple	$V_{IN} = 12.6V$ , $I_o = 200mA$	40mV pp P.A.R.D
Short Circuit Current	$V_{IN} = 12.6V$ , $R_L=0.1\Omega$	250mA
Efficiency	$V_{IN} = 12.6V$ , $I_o = 200mA$	72%

Switchmode Pulse Width Modulation Control Circuit

DIP-16



DIM	MILLIMETERS		INCHES	
	MIN	MAX	MIN	MAX
A	17.80	18.05	0.701	0.710
B	6.25	6.45	0.292	0.299
C	2.35	2.65	0.093	0.104
D	0.35	0.49	0.014	0.019
G	1.27BSC		0.05BSC	
J	0.25	0.32	0.010	0.012
K	0.10	0.25	0.004	0.009
L	0°	7°	0°	7°
M	-	10°	0.395	0.415

SOP-16

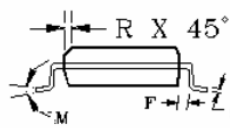
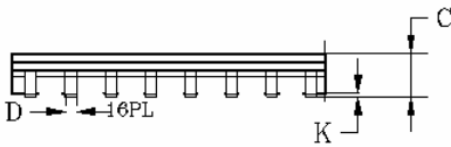
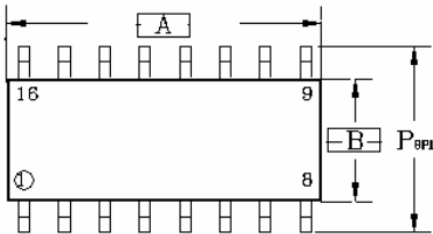

DIM	MILLIMETERS		INCHES	
	MIN	MAX	MIN	MAX
A	9.80	10.00	0.386	0.393
B	7.40	7.60	0.292	0.299
C	2.35	2.65	0.093	0.104
D	0.35	0.49	0.014	0.019
F	0.50	0.90	0.020	0.035
G	1.27BSC		0.05BSC	
K	0.10	0.25	0.004	0.009
M	0°	7°	0°	7°
P	10.05	10.55	0.395	0.415
R	0.25	0.75	0.010	0.029