

2SK685

SILICON N-CHANNEL MOS FET

高速度電力スイッチング

■ 特長

- オン抵抗が低い。
- スwitchングスピードが速い。
- 駆動電力が小さい。
- 2次降伏がない。
- スwitchングレギュレータ, DC-DCコンバータ, モータドライバなどに最適。

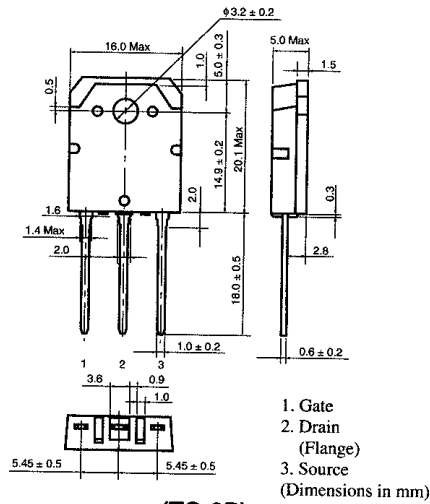
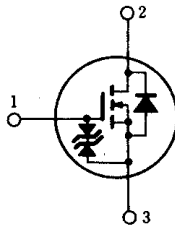

(TO-3P)

POWER VS. TEMPERATURE DERATING

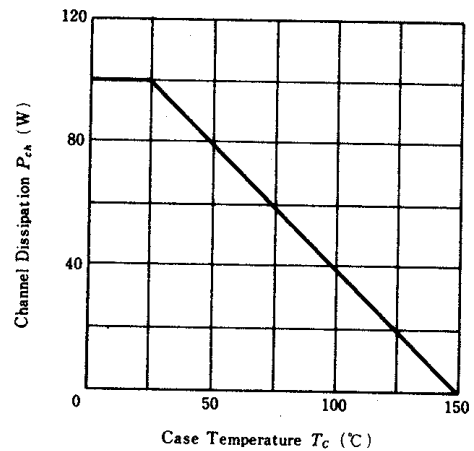

■ ABSOLUTE MAXIMUM RATINGS ($T_a=25^\circ\text{C}$)

Item	Symbol	Rating	Unit
Drain-Source Voltage	V_{DSS}	1000	V
Gate-Source Voltage	V_{GSS}	± 20	V
Drain Current	I_D	5	A
Drain Peak Current	$I_{D(pulse)}$ *	15	A
Body-Drain Diode Reverse Drain Current	I_{DR}	5	A
Channel Dissipation	P_{ch} **	100	W
Channel Temperature	T_{ch}	150	°C
Storage Temperature	T_{stg}	$-55 \sim +150$	°C

*PW $\leq 10\mu\text{s}$, duty cycle $\leq 1\%$ **Value at $T_c=25^\circ\text{C}$

■ ELECTRICAL CHARACTERISTICS ($T_a=25^\circ\text{C}$)

Item	Symbol	Test Condition	min.	typ.	max.	Unit
Drain-Source Breakdown Voltage	$V_{(BR)DSS}$	$I_D=10\text{mA}$, $V_{GS}=0$	1000	—	—	V
Gate-Source Breakdown Voltage	$V_{(BR)GSS}$	$I_G=\pm 100\mu\text{A}$, $V_{DS}=0$	± 20	—	—	V
Gate-Source Leak Current	I_{GSS}	$V_{GS}=\pm 16\text{V}$, $V_{DS}=0$	—	—	± 10	μA
Zero Gate Voltage Drain Current	I_{DSS}	$V_{DS}=800\text{V}$, $V_{GS}=0$	—	—	250	μA
Gate-Source Cutoff Voltage	$V_{GS(off)}$	$I_D=1\text{mA}$, $V_{DS}=10\text{V}$	2.0	—	4.0	V
Static Drain-Source on State Resistance	$R_{DS(on)}$	$I_D=3\text{A}$, $V_{GS}=10\text{V}$ *	—	1.5	2.0	Ω
Forward Transfer Admittance	$ y_{fs} $	$I_D=3\text{A}$, $V_{DS}=20\text{V}$ *	2.0	3.5	—	S
Input Capacitance	C_{iss}	$V_{DS}=10\text{V}$, $V_{GS}=0$, $f=1\text{MHz}$	—	1900	—	pF
Output Capacitance	C_{oss}		—	1200	—	pF
Reverse Transfer Capacitance	C_{rss}		—	760	—	pF
Turn-on Delay Time	$t_{d(on)}$	$I_D=3\text{A}$, $V_{GS}=10\text{V}$, $R_L=10\Omega$	—	25	—	ns
Rise Time	t_r		—	240	—	ns
Turn-off Delay Time	$t_{d(off)}$		—	220	—	ns
Fall Time	t_f		—	230	—	ns
Body-Drain Diode Forward Voltage	V_{DF}	$I_F=5\text{A}$, $V_{GS}=0$	—	1.3	—	V
Body-Drain Diode Reverse Recovery Time	t_{rr}	$I_F=5\text{A}$, $V_{GS}=0$, $di_F/dt=100\text{A}/\mu\text{s}$	—	150	—	ns

*Pulse Test