

FM IF limiter amplifier and detector

Description

The U 4270 B is an integrated bipolar FM-IF amplifier circuit with field strength indicator, stop signal generator,

multipath detector and controllable mute function. It is designed for car radios and home receiver applications.

Features

- 7 stage limiter amplifier
- Multipath signal detector
- Stop signal generator with controllable threshold
- Signal strength output
- Controllable mute function
- High signal/noise ratio and low signal distortion

Block Diagram

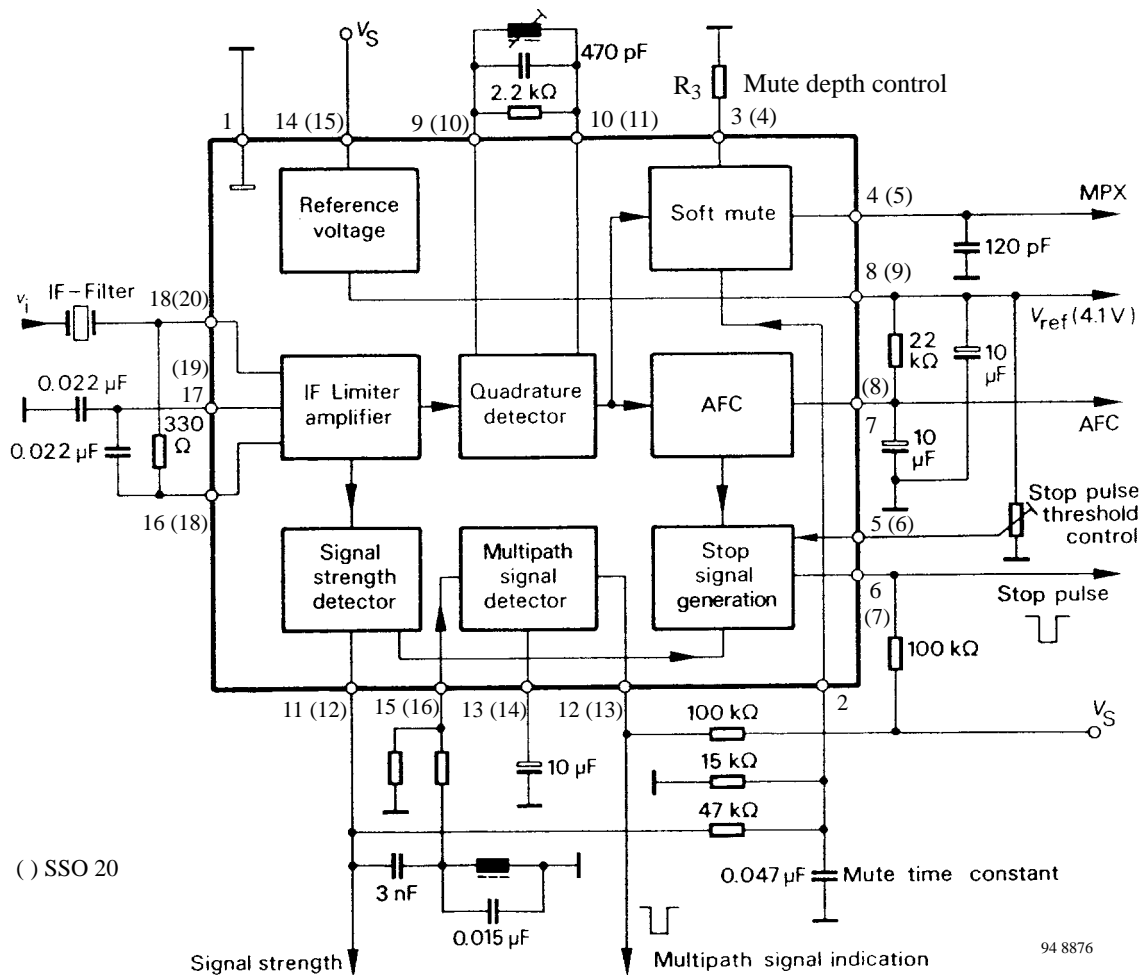

U 4270 B

Pin description

DIP 18	SSO 20	Symbol	Function
1	1	GND	Ground
2	2	MUTE IN	Mute input
–	3	NC	N.C.
3	4	MUTE DE	Mute depth
4	5	AF	AF output
5	6	STOP SEN	Search tuning stop sensitivity
6	7	STOP SIG	Search stop signal output
7	8	AFC	AFC output
8	9	RVOLT	Reference voltage output
9	10	DEMODO	Demodulator circuit
10	11	DEMODO	Demodulator circuit

DIP 18	SSO 20	Symbol	Function
11	12	FS	Field strength
12	13	MPOUT	Multipath identification output
13	14	RTC	Rectifier time constant
14	15	V _S	Supply voltage
15	16	MPIN	Multipath identification input
–	17	NC	N.C.
16	18	BFB	Bias feedback
17	19	BFB	Bias feedback
18	20	IF	IF input

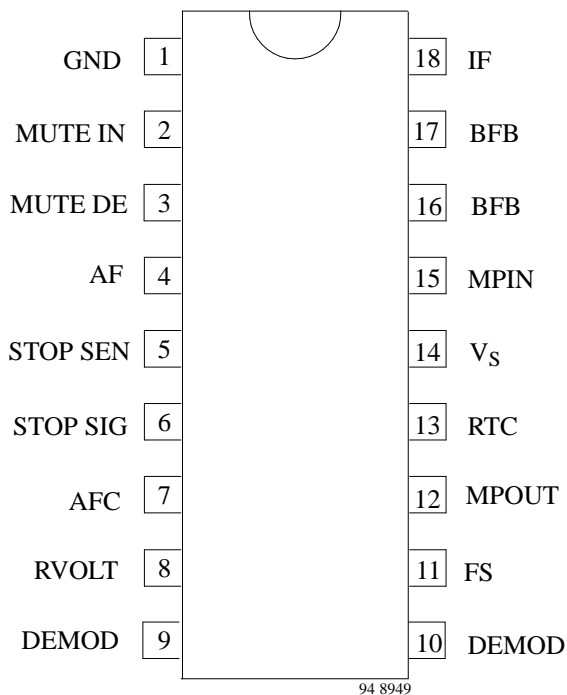

Absolute Maximum Ratings

Reference point Pin 1, unless otherwise specified

Parameters	Symbol	Value	Unit
Supply voltage Pin 14	V_S	18	V
Junction temperature	T_j	150	°C
Storage temperature range	T_{stg}	- 40 to + 150	°C
Ambient temperature range	T_{amb}	- 25 to + 85	°C

Thermal Resistance

Parameters	Symbol	Maximum	Unit
Junction ambient	R_{thJA}	100	K/W

Electrical Characteristics

$V_S = 8.5$ V, reference point Pin 1, $f_i = 10.7$ MHz, adjusted at $I_7 = 0$, $V_i = 10$ mV, FM-deviation ± 75 kHz, $f_{mod} = 1$ kHz, $Q_0 = 20$, $T_{amb} = 25$ °C, unless otherwise specified

Parameters	Test Conditions / Pin	Symbol	Min	Typ	Max	Unit
Supply voltage	Pin 14	V_S	7.5		15	V
Supply current	Pin 14	I_S	19		23	mA
Field strength output Pin 11						
Output voltage	$V_i = 200$ mV $V_i = 50$ mV $V_i = 1$ mV $V_i = 0$ mV	V_{OUT}	4.4 4.2 2.5 0.01		4.9 4.6 2.8 0.42	V
Audio output signal Pin 4						
Output voltage		V_{AF}	290		330	mV
Distortion		THD	0.48		0.88	%
(S+N)/N ratio	deviation ± 75 kHz	S+N/N	77		81	dB
AM-rejection	$m = 30$ %		62		66	dB
Mute depth	$V_2 = 0$ V, $R_3 = \infty$ $V_2 = 0$ V, $R_3 = 0$	a_{mute}	6.7 34	7 36	9 39	dB
Maximum sink current		I_4	0.9		1.1	mA
Stop signal output Pin 6						
Input frequency window	$R_{7-8} = 22$ k Ω	f_{win}	± 23		± 28	kHz
Output voltage HIGH LOW	$I_6 < 0.5$ mA	V_6	7	0.1	0.2	V
Input voltage threshold	$V_6 = 0.5$ V, Pin 5 open $V_6 = 0.5$ V, $V_5 = V_8$	V_i	25 0.6		45 1.3	μ V mV

Parameters	Test Conditions / Pin	Symbol	Min	Typ	Max	Unit
AFC output Pin 7						
Output current	deviation ± 50 kHz	$\pm I_{AFC}$	90	110	140	μ A
Input frequency offset	$I_{AFC} = 0$	$\pm f_{off}$	2		12	kHz
Reference voltage output Pin 8						
Output voltage	$I_8 = 0.5$ mA	V_8	3.9		4.2	V
Maximum load current		I_8		3	5	mA
Multipath detection Pin 12, 13, 15						
Detector threshold	$V_{12} < 1$ V, $f_{V15} = 20$ kHz	V_{15}	5.4		7	mV
Output leakage current	$V_{12} = V_S$	I_{12}		1.5		μ A
Charge current	Pin 15 connected to ground	I_{13}	3		3.6	mA
Discharge current	Pin 15 open circuit $V_{13} \leq 1$ V	I_{13}	-7		-10	μ A
Mute function Pin 2						
Mute "off" voltage	$V_{out} - 2$ dB	V_{off}	0.22		0.33	V
IF-Input signal Pin 18						
Limiting threshold	$V_{out} - 3$ dB	V_i	25		33	dB μ V

$V_S = 8.5$ V, reference point Pin 1, $f_i = 10.7$ MHz, adjusted at $I_7 = 0$, $V_i = 10$ mV, FM-deviation ± 75 kHz, $f_{mod} = 1$ kHz, $Q_0 = 20$, $T_{amb} = -40$ to $+85$ °C, unless otherwise specified

Parameters	Test Conditions / Pin	Symbol	Min	Typ	Max	Unit
Supply voltage	Pin 14	V_S	7.5		15	V
Supply current	Pin 14	I_S	17		25	mA
Field strength output Pin 11						
Output voltage	$V_i = 200$ mV $V_i = 50$ mV $V_i = 1$ mV $V_i = 0$ mV	V_{OUT}	4.0 3.6 2.25 0.01		5.0 4.7 2.95 0.42	V
Audio output signal Pin 4						
Output voltage		V_{AF}	250		370	mV
Distortion		THD	0.48		0.88	%
(S+N)/N ratio	deviation ± 75 kHz	S+N/N	70		81	dB
AM-rejection	$m = 30$ %		60		70	dB
Mute depth	$V_2 = 0$ V, $R_3 = \infty$ $V_2 = 0$ V, $R_3 = 0$	a_{mute}	6 34	7 36	10 40	dB
Maximum sink current		I_4	0.9		1.1	mA
Stop signal output Pin 6						
Input frequency window	$R_{7-8} = 22$ k Ω	f_{win}	± 23		± 39	kHz
Output voltage HIGH LOW	$I_6 < 0.5$ mA	V_6	7	0.1	0.5	V
Input voltage threshold	$V_6 = 0.5$ V, Pin 5 open $V_6 = 0.5$ V, $V_5 = V_8$	V_i	14 0.6	20	54 2.0	μ V mV

Parameters	Test Conditions / Pin	Symbol	Min	Typ	Max	Unit
AFC output Pin 7						
Output current	deviation ± 50 kHz	$\pm I_{AFC}$	60	110	140	μA
Input frequency offset	$I_{AFC} = 0$	$\pm f_{off}$		8	15	kHz
Reference voltage output Pin 8						
Output voltage	$I_8 = 0.5$ mA	V_8	3.7		4.2	V
Maximum load current		I_8		3	5	mA
Multipath detection Pin 12, 13, 15						
Detector threshold	$V_{12} < 1$ V, $f_{V15} = 20$ kHz	V_{15}	5.0		7	mV
Output leakage current	$V_{12} = V_S$	I_{12}		1.5		μA
Charge current	Pin 15 connected to ground	I_{13}	2.1		4.0	mA
Discharge current	Pin 15 open circuit $V_{13} \leq 1$ V	I_{13}	-6		-10	μA
Mute function Pin 2						
Mute "off voltage	$V_{out} - 2$ dB	V_{off}	0.22		0.33	V
IF-Input signal Pin 8						
Limiting threshold	$V_{out} - 3$ dB	V_i	25		33	dB μV

Test circuit:

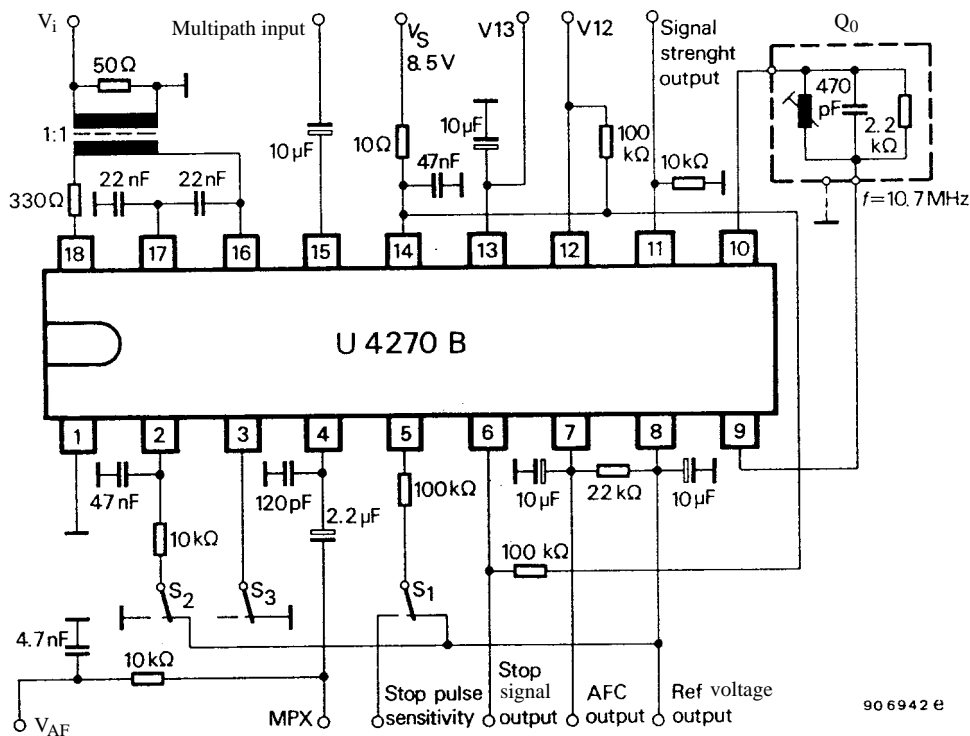

Ordering and package information

Extended type number	Package	Remarks
U 4270 B-CFS	SSO 20 plastic	
U 4270 B-CFSG3	SSO 20 plastic	Taping according to IEC-286-3
U 4270 B-C	DIP 18	

Dimensions in mm

Package DIP 18

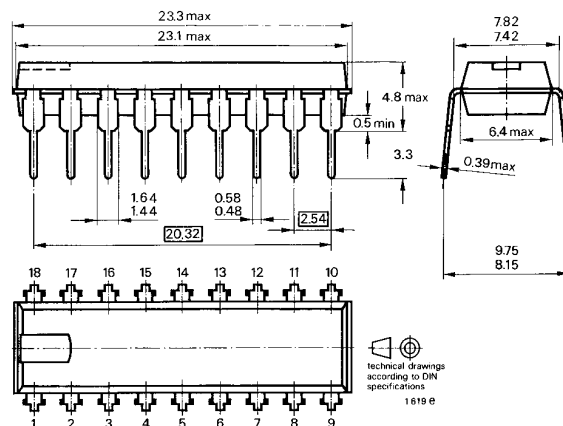

Package SSO 20

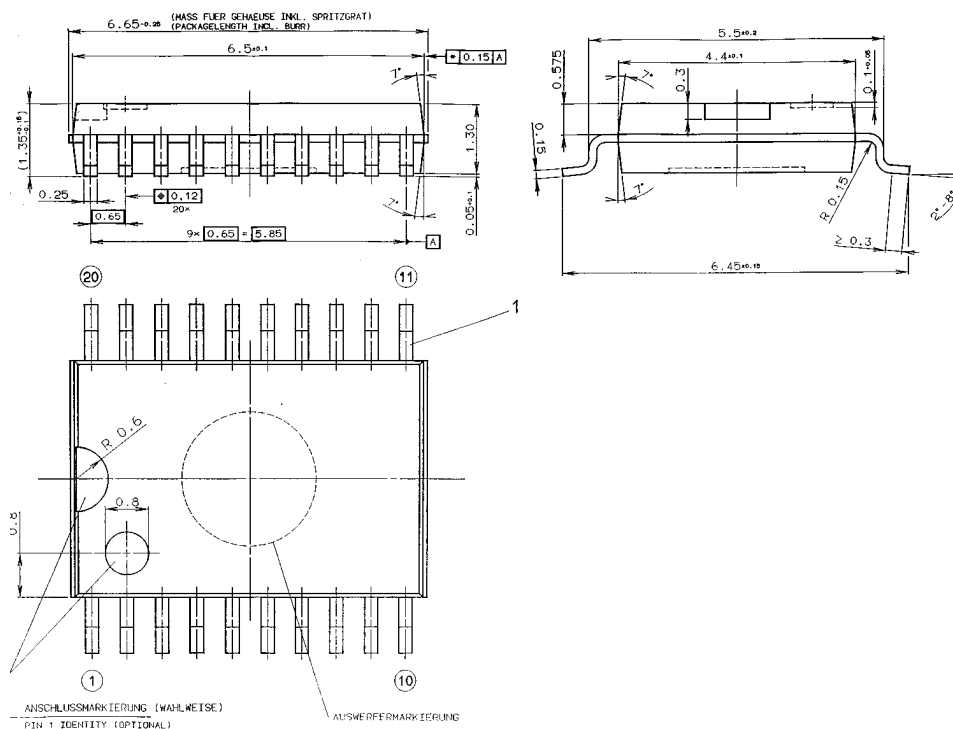

OZONE DEPLETING SUBSTANCES POLICY STATEMENT

It is the policy of **TEMIC TELEFUNKEN microelectronic GmbH** to

1. meet all present and future national and international statutory requirements and
2. regularly and continuously improve the performance of our products, processes, distribution and operating systems.
With respect to their impact on the health and safety of our employees and the public, as well as their impact on the environment.

Of particular concern is the control or elimination of releases into the atmosphere of substances who are known as ozone depleting substances (ODS's).

The Montreal Protocol (1987) and its London Amendments (1990) will severely restrict the consumption of ODS's and forbid their use within the next ten years. Various national and international initiatives are pressing for an earlier ban on these substances.

TEMIC TELEFUNKEN microelectronic GmbH semiconductor division has been able to use its policy of continuous improvements to eliminate the use of any ODS's listed in the following documents that all refer to the same substances:

- (1) Annex A, B and list of transitional substances of the Montreal Protocol and the London Amendments respectively
- (2) Class I and II ozone depleting substances in the Clean Air Act Amendments of 1990 by the Environmental Protection Agency (EPA) in the USA and
- (3) Council Decision 88/540/EEC and 91/690/EEC Annex A, B and C (transitional substances) respectively.

TEMIC can certify, that our semiconductors are not manufactured with and do not contain ozone depleting substances.

We reserve the right to make changes without further notice to improve technical design.

Parameters can vary in different applications. All operating parameters must be validated for each customer application by customer. Should Buyer use TEMIC products for any unintended or unauthorized application, Buyer shall indemnify TEMIC against all claims, costs, damages, and expenses, arising out of, directly or indirectly, any claim of personal damage, injury or death associated with such unintended or unauthorized use.

TEMIC TELEFUNKEN microelectronic GmbH, P.O.B. 3535, D-74025 Heilbronn, Germany
Telephone: 49 (0)7131 67 2831, Fax Number: 49 (0)7131 67 2423