



M41T62, M41T63 M41T64, M41T65

Serial Access Real-Time Clock with Alarms

PRELIMINARY DATA

FEATURES SUMMARY

- TIMEKEEPING DOWN TO 1.0V
- 1.3V TO 3.6V I²C BUS OPERATING VOLTAGE
- COUNTERS FOR TENTHS/HUNDREDTHS OF SECONDS, SECONDS, MINUTES, HOURS, DAY, DATE, MONTH, YEAR, AND CENTURY
- SERIAL INTERFACE SUPPORTS I²C BUS (400KHz)
- PROGRAMMABLE ALARM WITH FLAG BIT ONLY (M41T63/64)
- PROGRAMMABLE ALARM WITH INTERRUPT FUNCTION (M41T62/65)
- LOW OPERATING CURRENT OF 350µA
- SOFTWARE CLOCK CALIBRATION
- OSCILLATOR STOP DETECTION
- 32KHz SQUARE WAVE ON POWER-UP (M41T62/63/64)
- WATCHDOG TIMER
- WATCHDOG OUTPUT (M41T63/65)
- AUTOMATIC LEAP YEAR COMPENSATION
- OPERATING TEMPERATURE OF -40 TO 85°C
- LEAD-FREE 16-PIN QFN PACKAGE

Figure 1. Package

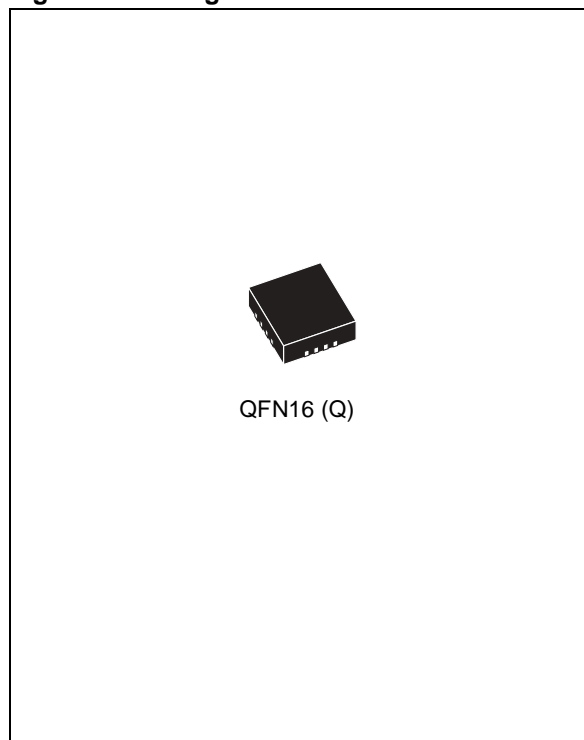

Table 1. Device Options

	Basic RTC	Alarms	OSC Fail Detect	Watchdog Timer	Calibration	SQW Output	IRQ Output	WDO Output	F _{32k}
M41T62	✓	✓	✓	✓	✓	✓	✓		
M41T63	✓	✓	✓	✓	✓	✓		✓	
M41T64	✓	✓	✓	✓	✓	✓			✓
M41T65	✓	✓	✓	✓	✓		✓	✓	

TABLE OF CONTENTS

FEATURES SUMMARY	1
Figure 1. Package	1
Table 1. Device Options	1
SUMMARY DESCRIPTION	4
Figure 2. M41T62 Logic Diagram	4
Figure 3. M41T64 Logic Diagram	4
Figure 4. M41T63 Logic Diagram	4
Figure 5. M41T65 Logic Diagram	4
Figure 6. M41T62 16-pin QFN Connections	5
Figure 7. M41T63 16-pin QFN Connections	5
Figure 8. M41T64 16-pin QFN Connections	5
Figure 9. M41T65 16-pin QFN Connections	5
Table 2. Signal Names	5
Figure 10. M41T62 Block Diagram	6
Figure 11. M41T63 Block Diagram	6
Figure 12. M41T64 Block Diagram	6
Figure 13. M41T65 Block Diagram	7
OPERATION	7
2-Wire Bus Characteristics	7
Bus not busy	7
Start data transfer	7
Stop data transfer	7
Data Valid	7
Acknowledge	8
Figure 14. Serial Bus Data Transfer Sequence	8
Figure 15. Acknowledgement Sequence	8
READ Mode	9
Figure 16. Slave Address Location	9
Figure 17. READ Mode Sequence	10
Figure 18. Alternative READ Mode Sequence	10
WRITE Mode	11
Figure 19. WRITE Mode Sequence	11
CLOCK OPERATION	12
TIMEKEEPER® Registers	12
Table 3. M41T62 Register Map	13
Table 4. M41T63 Register Map	14
Table 5. M41T64 Register Map	15
Table 6. M41T65 Register Map	16
Calibrating the Clock	17
Figure 20. Crystal Accuracy Across Temperature	18

Figure 21. Calibration Waveform	18
Setting Alarm Clock Registers	19
Figure 22. Alarm Interrupt Reset Waveform	19
Table 7. Alarm Repeat Modes	19
Watchdog Timer	20
Watchdog Output (WDO - M41T63/65 only)	20
Square Wave Output (M41T62/63/64)	21
Table 8. Square Wave Output Frequency	21
Full-time 32KHz Square Wave Output (M41T64)	21
Century Bits	22
Output Driver Pin (M41T62/65)	22
Oscillator Stop Detection	22
Initial Power-on Defaults	22
Table 9. Initial Power-on Default Values	22
Table 10. Century Bits Examples	22
MAXIMUM RATING	23
Table 11. Absolute Maximum Ratings	23
DC AND AC PARAMETERS	24
Table 12. Operating and AC Measurement Conditions	24
Figure 23. AC Measurement I/O Waveform	24
Figure 24. Crystal Isolation Example	24
Table 13. Capacitance	24
Table 14. DC Characteristics	25
Table 15. Crystal Electrical Characteristics	25
Figure 25. Bus Timing Requirements Sequence	26
Table 16. AC Characteristics	26
PACKAGE MECHANICAL INFORMATION	27
Figure 26. QFN16 – 16-lead, Quad, Flat Package, No Lead, 3x3mm body size, Outline	27
Table 17. QFN16 – 16-lead, Quad, Flat Package, No Lead, 3x3mm body size, Mechanical Data	28
Figure 27. QFN16 – 16-lead, Quad, Flat Package, No Lead, 3x3mm body size, Footprint	28
PART NUMBERING	29
Table 18. Ordering Information Scheme	29
REVISION HISTORY	30
Table 19. Document Revision History	30

SUMMARY DESCRIPTION

The M41T6X Serial Access TIMEKEEPER® is a low power Serial RTC with a built-in 32.768 KHz oscillator (external crystal controlled). Eight registers (see Table 3., page 13) are used for the clock/calendar function and are configured in binary coded decimal (BCD) format. An additional 8 registers provide status/control of Alarm, 32KHz output, Calibration, and Watchdog functions. Addresses and data are transferred serially via a two line, bi-directional I²C interface. The built-in address register is incremented automatically after each WRITE or READ data byte.

Functions available to the user include a time-of-day clock/calendar, Alarm interrupts (M41T62/65), 32KHz output (M41T64), programmable Square Wave output (M41T62/63/64), and Watchdog output (M41T63/65). The eight clock address locations contain the century, year, month, date, day, hour, minute, second and tenths/hundredths of a second in 24 hour BCD format. Corrections for 28-, 29- (leap year), 30- and 31-day months are made automatically.

The M41T6X is supplied in a 16-pin QFN.

Figure 2. M41T62 Logic Diagram

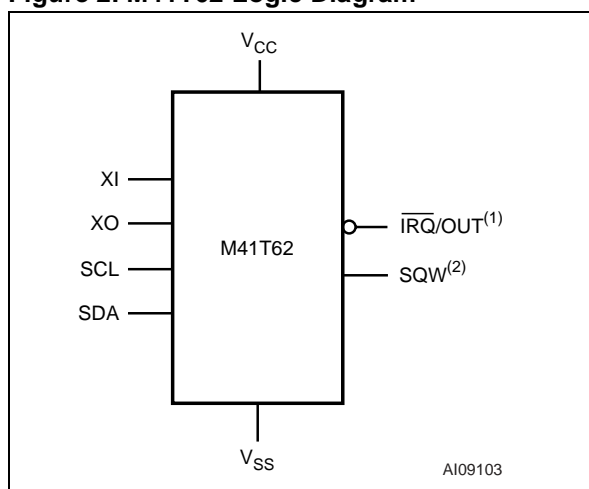

Note: 1. Open Drain.
2. Defaults to 32KHz on power-up.

Figure 4. M41T63 Logic Diagram

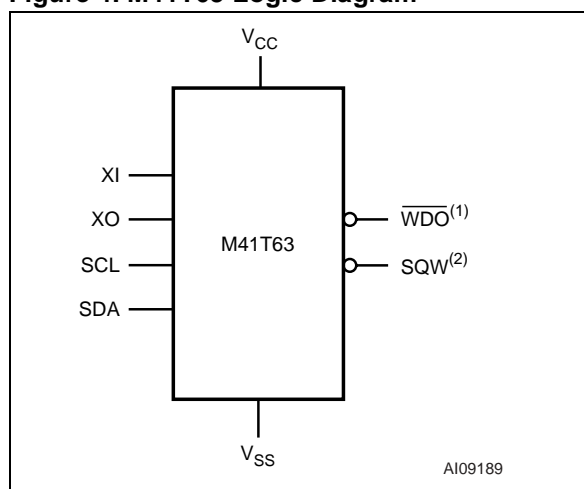

Note: 1. Open Drain.
2. Defaults to 32KHz on power-up.

Figure 3. M41T64 Logic Diagram

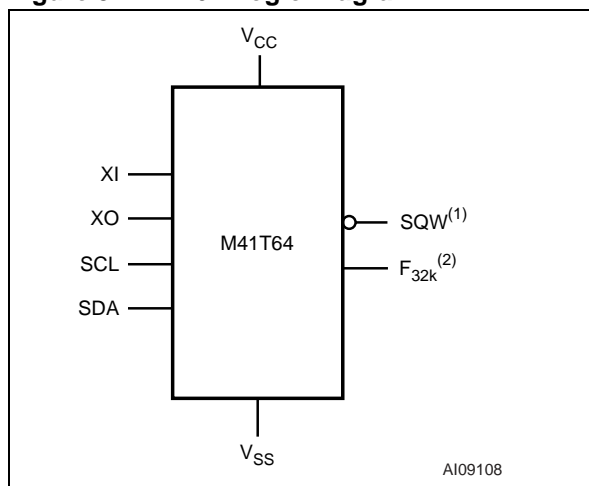

Note: 1. Open Drain.
2. Defaults to 32KHz on power-up.

Figure 5. M41T65 Logic Diagram

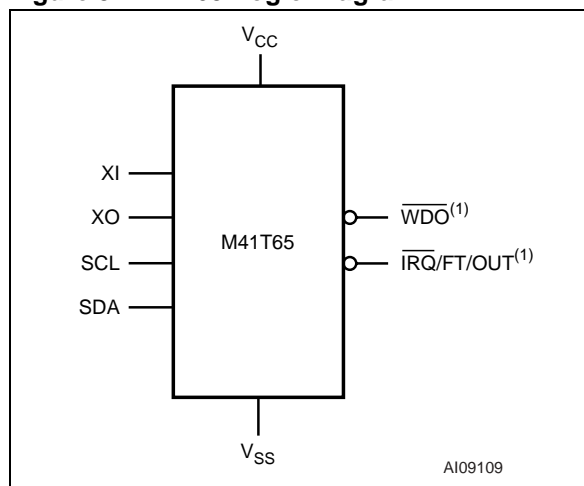

Note: 1. Open Drain.

Figure 6. M41T62 16-pin QFN Connections

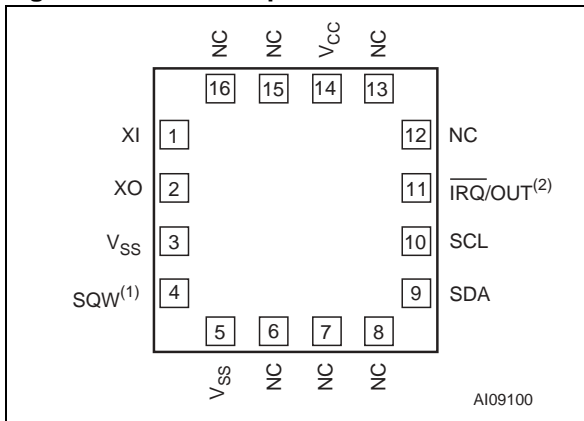

Note: 1. SQW Output will default to 32KHz upon power-up.
2. Open Drain.

Figure 9. M41T65 16-pin QFN Connections

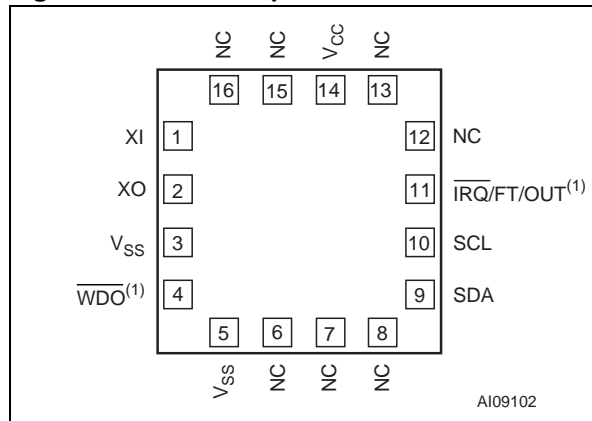

Note: 1. Open Drain.

Figure 7. M41T63 16-pin QFN Connections

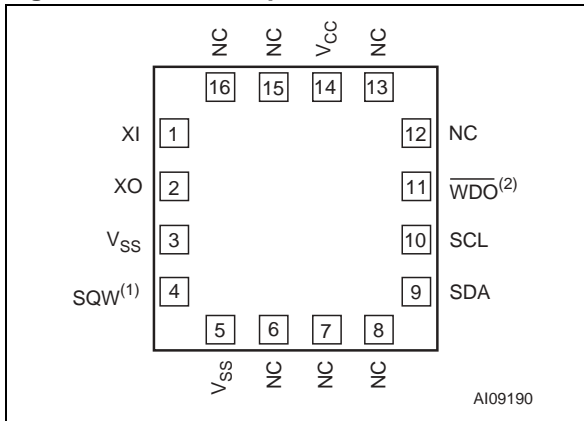

Note: 1. SQW Output will default to 32KHz upon power-up.
2. Open Drain.

Figure 8. M41T64 16-pin QFN Connections

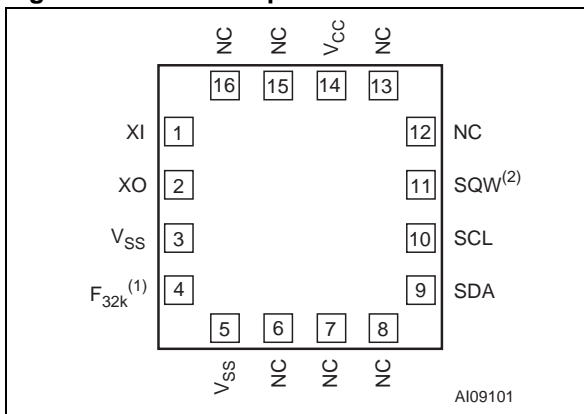

Note: 1. Enabled on power-up.
2. Open Drain.

Table 2. Signal Names

XI	Oscillator Input
XO	Oscillator Output
SDA	Serial Data Input/Output
SCL	Serial Clock Input
IRQ/OUT	Interrupt or OUT Output (Open Drain)
IRQ/FT/OUT	Interrupt, Frequency Test, or OUT Output (Open Drain)
SQW	Programmable Square Wave - Defaults to 32KHz on Power-up (Open Drain for M41T64 only)
F _{32k}	Dedicated 32KHz Output
WDO	Watchdog Timer Output (Open Drain)
V _{CC}	Supply Voltage
V _{SS}	Ground

M41T62/63/64/65

Figure 10. M41T62 Block Diagram

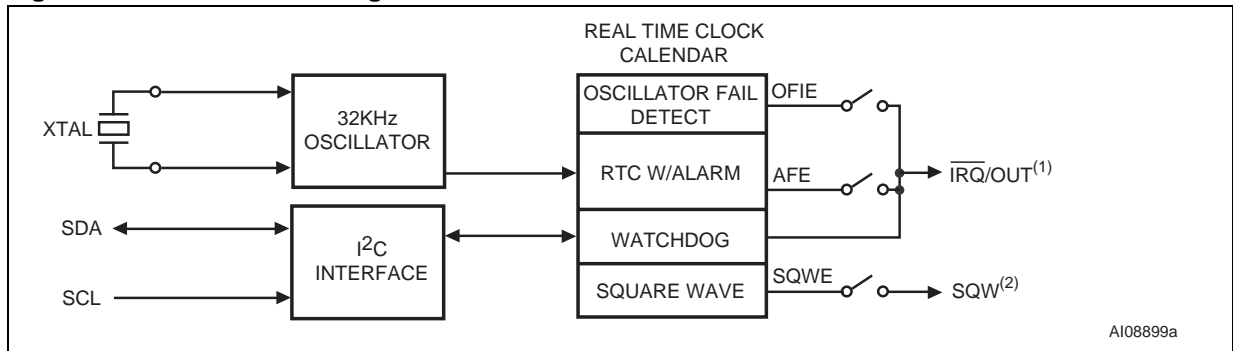

Note: 1. Open Drain.
2. Defaults to 32KHz on power-up.

Figure 11. M41T63 Block Diagram

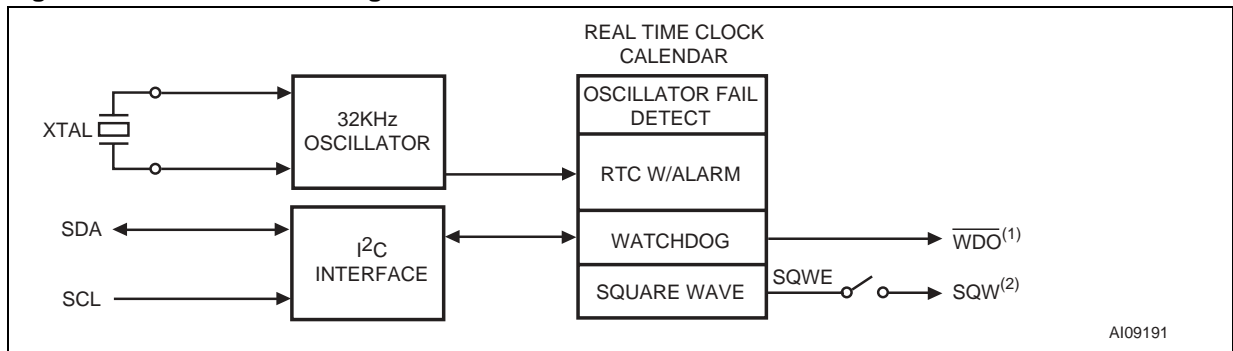

Note: 1. Open Drain.
2. Defaults to 32KHz on power-up.

Figure 12. M41T64 Block Diagram

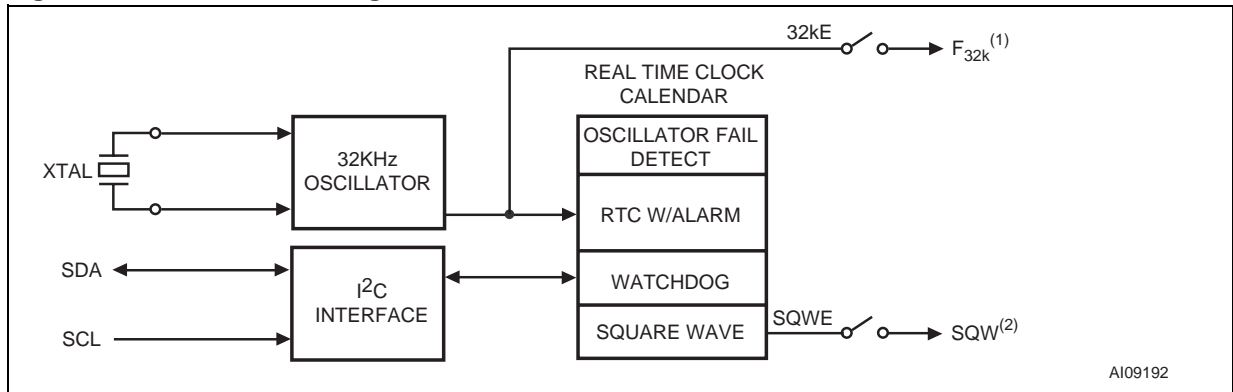

Note: 1. Defaults enabled on power-up.
2. Open Drain.

Figure 13. M41T65 Block Diagram

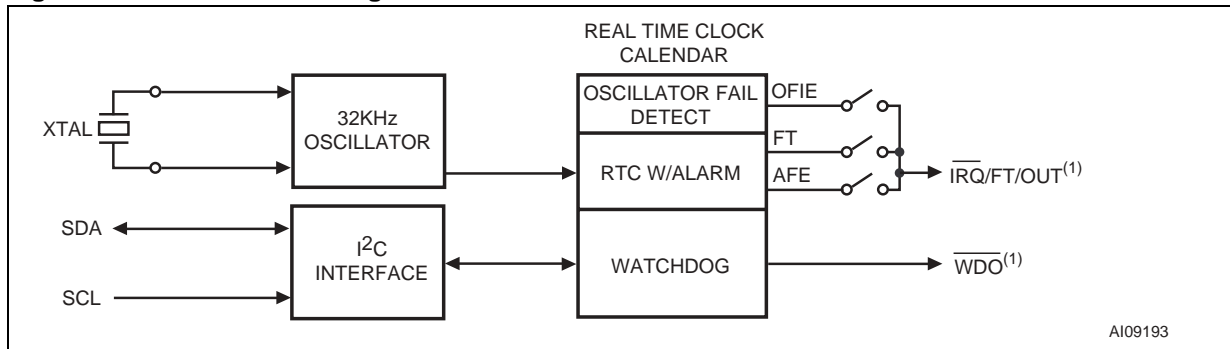

Note: 1. Open Drain.

OPERATION

The M41T6X clock operates as a slave device on the serial bus. Access is obtained by implementing a start condition followed by the correct slave address (D0h). The 16 bytes contained in the device can then be accessed sequentially in the following order:

1. Tenths/Hundredths of a Second Register
2. Seconds Register
3. Minutes Register
4. Hours Register
5. Square Wave/Day Register
6. Date Register
7. Century/Month Register
8. Year Register
9. Calibration Register
10. Watchdog Register
- 11 - 15. Alarm Registers
16. Flags Register

2-Wire Bus Characteristics

The bus is intended for communication between different ICs. It consists of two lines: a bi-directional data signal (SDA) and a clock signal (SCL). Both the SDA and SCL lines must be connected to a positive supply voltage via a pull-up resistor.

The following protocol has been defined:

- Data transfer may be initiated only when the bus is not busy.
- During data transfer, the data line must remain stable whenever the clock line is High.
- Changes in the data line, while the clock line is High, will be interpreted as control signals.

Accordingly, the following bus conditions have been defined:

Bus not busy. Both data and clock lines remain High.

Start data transfer. A change in the state of the data line, from high to Low, while the clock is High, defines the START condition.

Stop data transfer. A change in the state of the data line, from Low to High, while the clock is High, defines the STOP condition.

Data Valid. The state of the data line represents valid data when after a start condition, the data line is stable for the duration of the high period of the clock signal. The data on the line may be changed during the Low period of the clock signal. There is one clock pulse per bit of data.

Each data transfer is initiated with a start condition and terminated with a stop condition. The number of data bytes transferred between the start and stop conditions is not limited. The information is transmitted byte-wide and each receiver acknowledges with a ninth bit.

By definition a device that gives out a message is called “transmitter,” the receiving device that gets the message is called “receiver.” The device that controls the message is called “master.” The devices that are controlled by the master are called “slaves.”

Acknowledge. Each byte of eight bits is followed by one Acknowledge Bit. This Acknowledge Bit is a low level put on the bus by the receiver whereas the master generates an extra acknowledge related clock pulse. A slave receiver which is addressed is obliged to generate an acknowledge after the reception of each byte that has been clocked out of the slave transmitter.

in such a way that the SDA line is a stable Low during the High period of the acknowledge related clock pulse. Of course, setup and hold times must be taken into account. A master receiver must signal an end of data to the slave transmitter by not generating an acknowledge on the last byte that has been clocked out of the slave. In this case the transmitter must leave the data line High to enable the master to generate the STOP condition.

The device that acknowledges has to pull down the SDA line during the acknowledge clock pulse

Figure 14. Serial Bus Data Transfer Sequence

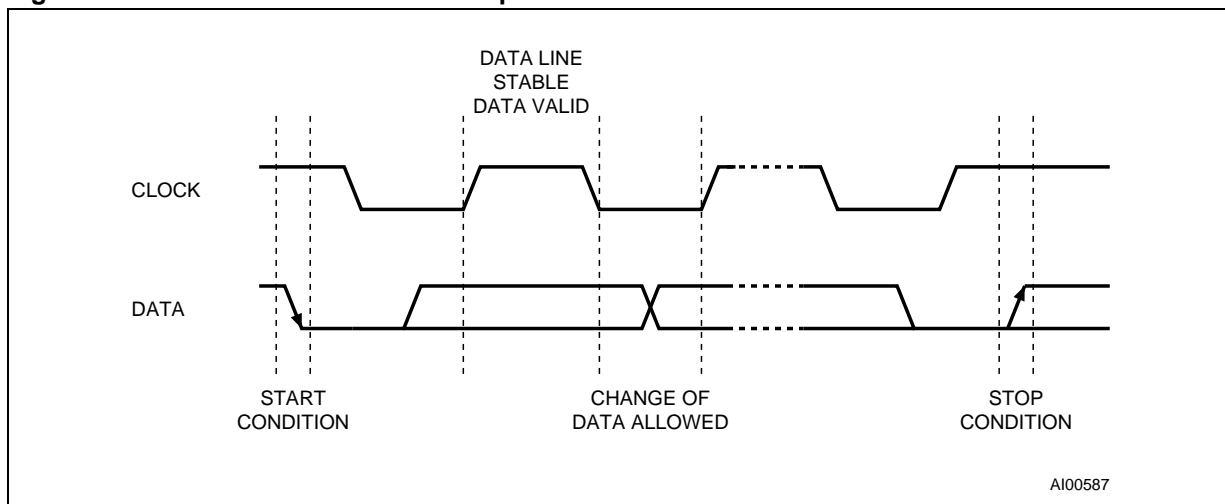
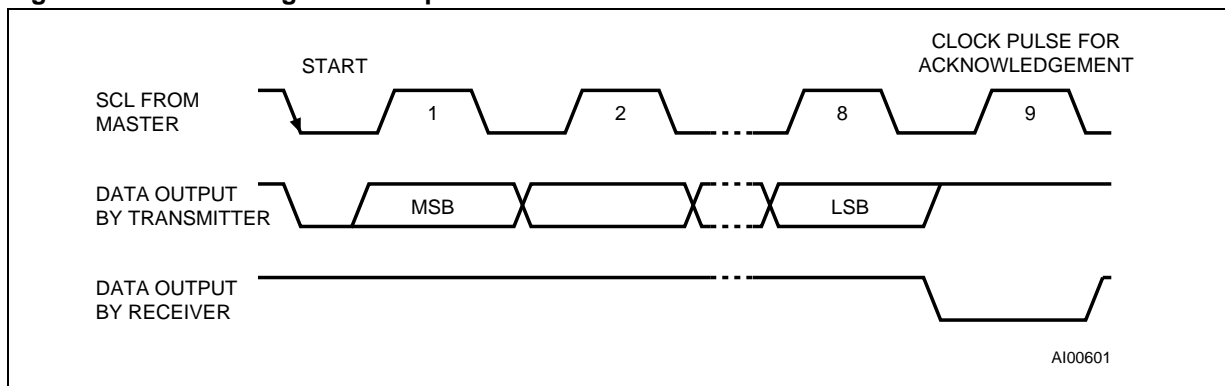

Figure 15. Acknowledgement Sequence



READ Mode

In this mode the master reads the M41T6X slave after setting the slave address (see Figure 17., page 10). Following the WRITE Mode Control Bit ($R/\overline{W}=0$) and the Acknowledge Bit, the word address 'An' is written to the on-chip address pointer. Next the START condition and slave address are repeated followed by the READ Mode Control Bit ($R/\overline{W}=1$). At this point the master transmitter becomes the master receiver. The data byte which was addressed will be transmitted and the master receiver will send an Acknowledge Bit to the slave transmitter. The address pointer is only incremented on reception of an Acknowledge Clock. The M41T6X slave transmitter will now place the data byte at address An+1 on the bus, the master receiver reads and acknowledges the new byte and the address pointer is incremented to "An+2."

This cycle of reading consecutive addresses will continue until the master receiver sends a STOP condition to the slave transmitter.

The system-to-user transfer of clock data will be halted whenever the address being read is a clock address (00h to 07h). The update will resume due to a Stop Condition or when the pointer increments to any non-clock address (08h-0Fh).

Note: This is true both in READ Mode and WRITE Mode.

An alternate READ Mode may also be implemented whereby the master reads the M41T6X slave without first writing to the (volatile) address pointer. The first address that is read is the last one stored in the pointer (see Figure 18., page 10).

Figure 16. Slave Address Location

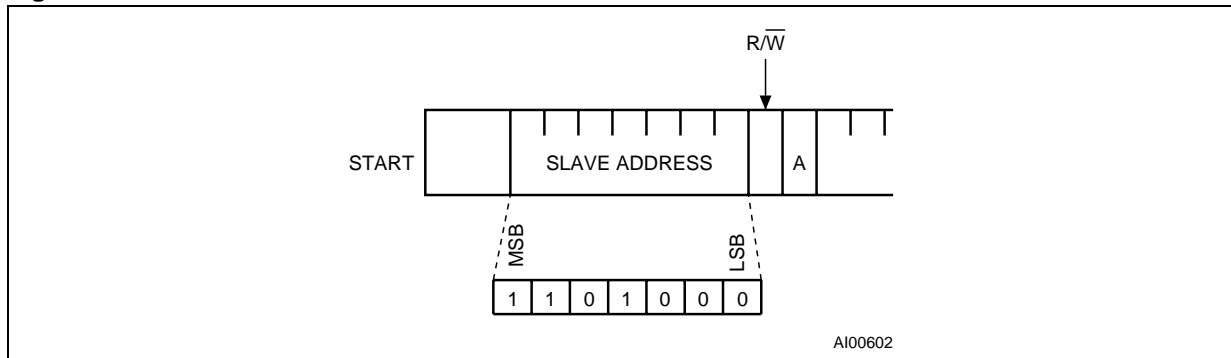

Figure 17. READ Mode Sequence

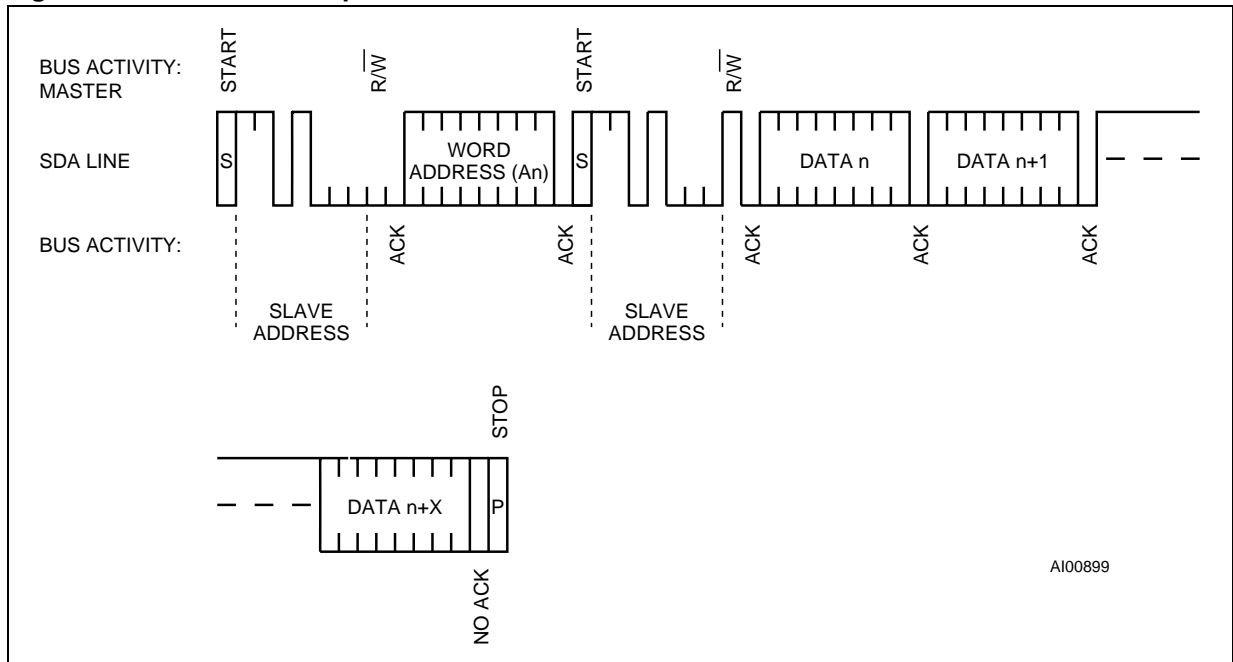
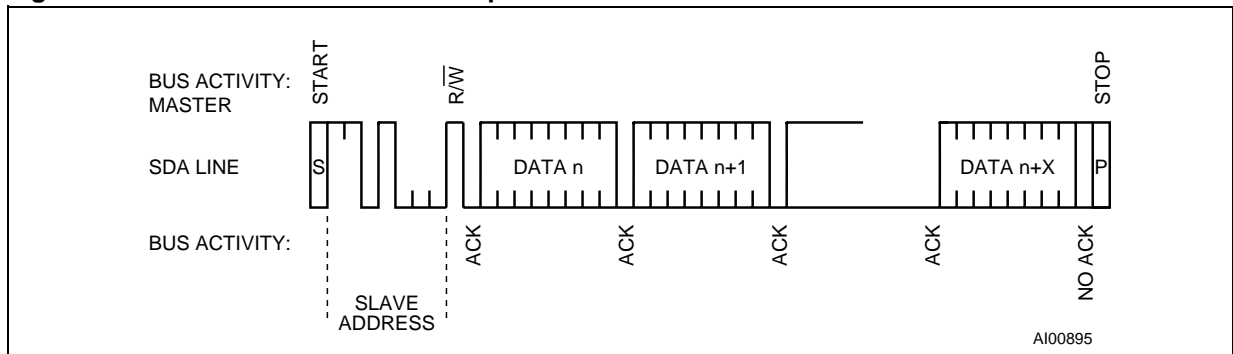

Figure 18. Alternative READ Mode Sequence



WRITE Mode

In this mode the master transmitter transmits to the M41T6X slave receiver. Bus protocol is shown in Figure 19., page 11. Following the START condition and slave address, a logic '0' (R/W=0) is placed on the bus and indicates to the addressed device that word address "An" will follow and is to be written to the on-chip address pointer. The data word to be written to the memory is strobed in next

and the internal address pointer is incremented to the next address location on the reception of an acknowledge clock. The M41T6X slave receiver will send an acknowledge clock to the master transmitter after it has received the slave address see Figure 16., page 9 and again after it has received the word address and each data byte.

Figure 19. WRITE Mode Sequence

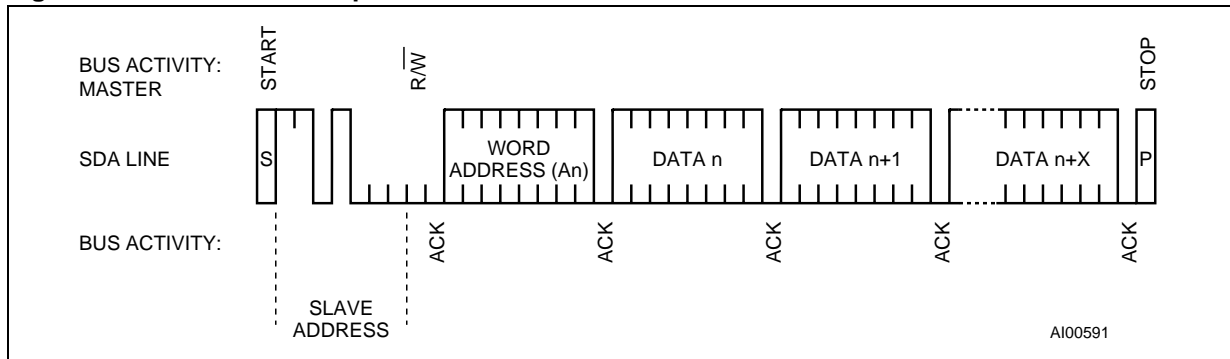

CLOCK OPERATION

The M41T6X is driven by a quartz-controlled oscillator with a nominal frequency of 32.768KHz. The accuracy of the Real-Time Clock depends on the frequency of the quartz crystal that is used as the time-base for the RTC. The M41T6X is tested to meet ± 35 ppm with a nominal crystal.

The eight byte clock register (see Table 3., page 13) is used to both set the clock and to read the date and time from the clock, in a binary coded decimal format. Tenths/Hundredths of Seconds, Seconds, Minutes, and Hours are contained within the first four registers.

Note: A WRITE to any clock register will result in the Tenths/Hundredths of Seconds being reset to "00," and Tenths/Hundredths of Seconds cannot be written to any value other than "00."

Bits D0 through D2 of Register 04h contain the Day (day of week). Registers 05h, 06h, and 07h contain the Date (day of month), Month, and Years. The ninth clock register is the Calibration Register (this is described in the Clock Calibration section). Bit D7 of Register 01h contains the STOP Bit (ST). Setting this bit to a '1' will cause the oscillator to stop. When reset to a '0' the oscillator restarts within one second (typical).

Note: Upon initial power-up, the user should set the ST Bit to a '1,' then immediately reset the ST Bit to '0.' This provides an additional "kick-start" to the oscillator circuit.

Bit D7 of Register 02h (Minute Register) contains the Oscillator Fail Interrupt Enable Bit (OFIE). When the user sets this bit to '1,' any condition which sets the Oscillator Fail Bit (OF) (see Oscillator Stop Detection, page 22) will also generate an interrupt output.

Bits D6 and D7 of Clock Register 06h (Century/Month Register) contain the CENTURY Bit 0 (CB0) and CENTURY Bit 1 (CB1).

Note: A WRITE to ANY location within the first eight bytes of the clock register (00h-07h), including the OFIE Bit, RS0-RS3 Bit, and CB0-CB1 Bits will result in an update of the system clock and a reset of the divider chain. This could result in an inadvertent change of the current time. These non-clock related bits should be written prior to setting the clock, and remain unchanged until such time as a new clock time is also written.

The eight Clock Registers may be read one byte at a time, or in a sequential block. Provision has been made to assure that a clock update does not occur while any of the eight clock addresses are being read. If a clock address is being read, an update of the clock registers will be halted. This will prevent a transition of data during the READ.

TIMEKEEPER® Registers

The M41T6X offers 16 internal registers which contain Clock, Calibration, Alarm, Watchdog, Flags, and Square Wave. The Clock registers are memory locations which contain external (user accessible) and internal copies of the data (usually referred to as BiPORT™ TIMEKEEPER cells). The external copies are independent of internal functions except that they are updated periodically by the simultaneous transfer of the incremented internal copy. The internal divider (or clock) chain will be reset upon the completion of a WRITE to any clock address (00h to 07h).

The system-to-user transfer of clock data will be halted whenever the address being read is a clock address (00h to 07h). The update will resume either due to a Stop Condition or when the pointer increments to a non-clock address.

TIMEKEEPER and Alarm Registers store data in BCD format. Calibration, Watchdog, and Square Wave Bits are written in a Binary Format.

Table 3. M41T62 Register Map

Addr									Function/Range BCD Format	
	D7	D6	D5	D4	D3	D2	D1	D0		
00h	0.1 Seconds				0.01 Seconds				10ths/100ths of Seconds	00-99
01h	ST	10 Seconds			Seconds				Seconds	00-59
02h	OFIE	10 Minutes			Minutes				Minutes	00-59
03h	0	0	10 Hours		Hours (24 Hour Format)				Hours	00-23
04h	RS3	RS2	RS1	RS0	0	Day of Week			Day	01-7
05h	0	0	10 Date		Date: Day of Month				Date	01-31
06h	CB1	CB0	0	10M	Month				Century/ Month	0-3/01-12
07h	10 Years				Year				Year	00-99
08h	OUT	0	S	Calibration				Calibration		
09h	RB2	BMB4	BMB3	BMB2	BMB1	BMB0	RB1	RB0	Watchdog	
0Ah	AFE	SQWE	0	AI 10M	Alarm Month				AI Month	01-12
0Bh	RPT4	RPT5	AI 10 Date		Alarm Date				AI Date	01-31
0Ch	RPT3	0	AI 10 Hour		Alarm Hour				AI Hour	00-23
0Dh	RPT2	Alarm 10 Minutes			Alarm Minutes				AI Min	00-59
0Eh	RPT1	Alarm 10 Seconds			Alarm Seconds				AI Sec	00-59
0Fh	WDF	AF	0	0	0	OF	0	0	Flags	

Keys: 0 = Must be set to '0'

AF = Alarm Flag (Read only)
 AFE = Alarm Flag Enable Flag
 BMB0 - BMB4 = Watchdog Multiplier Bits
 CB0-CB1 = Century Bits
 OF = Oscillator Fail Bit
 OFIE = Oscillator Fail Interrupt Enable Bit
 OUT = Output level

RB0 - RB2 = Watchdog Resolution Bits
 RPT1-RPT5 = Alarm Repeat Mode Bits
 RS0-RS3 = SQW Frequency Bits
 S = Sign Bit
 SQWE = Square Wave Enable Bit
 ST = Stop Bit
 WDF = Watchdog Flag Bit (Read only)

Table 4. M41T63 Register Map

Addr									Function/Range BCD Format	
	D7	D6	D5	D4	D3	D2	D1	D0		
00h	0.1 Seconds				0.01 Seconds				10ths/100ths of Seconds	00-99
01h	ST	10 Seconds			Seconds				Seconds	00-59
02h	0	10 Minutes			Minutes				Minutes	00-59
03h	0	0	10 Hours		Hours (24 Hour Format)				Hours	00-23
04h	RS3	RS2	RS1	RS0	0	Day of Week			Day	01-7
05h	0	0	10 Date		Date: Day of Month				Date	01-31
06h	CB1	CB0	0	10M	Month				Century/ Month	0-3/01-12
07h	10 Years				Year				Year	00-99
08h	0	0	S	Calibration					Calibration	
09h	RB2	BMB4	BMB3	BMB2	BMB1	BMB0	RB1	RB0	Watchdog	
0Ah	0	SQWE	0	AI 10M	Alarm Month				AI Month	01-12
0Bh	RPT4	RPT5	AI 10 Date		Alarm Date				AI Date	01-31
0Ch	RPT3	0	AI 10 Hour		Alarm Hour				AI Hour	00-23
0Dh	RPT2	Alarm 10 Minutes			Alarm Minutes				AI Min	00-59
0Eh	RPT1	Alarm 10 Seconds			Alarm Seconds				AI Sec	00-59
0Fh	WDF	AF	0	0	0	OF	0	0	Flags	

Keys: 0 = Must be set to '0'

AF = Alarm Flag (Read only)
 BMB0 - BMB4 = Watchdog Multiplier Bits
 CB0-CB1 = Century Bits
 OF = Oscillator Fail Bit
 RB0 - RB2 = Watchdog Resolution Bits

RPT1-RPT5 = Alarm Repeat Mode Bits
 RS0-RS3 = SQW Frequency Bits
 S = Sign Bit
 SQWE = Square Wave Enable Bit
 ST = Stop Bit
 WDF = Watchdog Flag Bit (Read only)



Table 5. M41T64 Register Map

Addr									Function/Range BCD Format	
	D7	D6	D5	D4	D3	D2	D1	D0		
00h	0.1 Seconds				0.01 Seconds				10ths/100ths of Seconds	00-99
01h	ST	10 Seconds			Seconds				Seconds	00-59
02h	0	10 Minutes			Minutes				Minutes	00-59
03h	0	0	10 Hours		Hours (24 Hour Format)				Hours	00-23
04h	RS3	RS2	RS1	RS0	0	Day of Week			Day	01-7
05h	0	0	10 Date		Date: Day of Month				Date	01-31
06h	CB1	CB0	0	10M	Month				Century/ Month	0-3/01-12
07h	10 Years				Year				Year	00-99
08h	0	0	S	Calibration					Calibration	
09h	RB2	BMB4	BMB3	BMB2	BMB1	BMB0	RB1	RB0	Watchdog	
0Ah	0	SQWE	32kE	AI 10M	Alarm Month				AI Month	01-12
0Bh	RPT4	RPT5	AI 10 Date		Alarm Date				AI Date	01-31
0Ch	RPT3	0	AI 10 Hour		Alarm Hour				AI Hour	00-23
0Dh	RPT2	Alarm 10 Minutes			Alarm Minutes				AI Min	00-59
0Eh	RPT1	Alarm 10 Seconds			Alarm Seconds				AI Sec	00-59
0Fh	WDF	AF	0	0	0	OF	0	0	Flags	

Keys: 0 = Must be set to '0'

32kE = 32KHz Enable Bit

AF = Alarm Flag (Read only)

BMB0 - BMB4 = Watchdog Multiplier Bits

CB0-CB1 = Century Bits

OF = Oscillator Fail Bit

RB0 - RB2 = Watchdog Resolution Bits

RPT1-RPT5 = Alarm Repeat Mode Bits

RS0-RS3 = SQW Frequency Bits

S = Sign Bit

SQWE = Square Wave Enable Bit

ST = Stop Bit

WDF = Watchdog Flag Bit (Read only)

Table 6. M41T65 Register Map

Addr									Function/Range BCD Format		
	D7	D6	D5	D4	D3	D2	D1	D0			
00h	0.1 Seconds				0.01 Seconds				10ths/100ths of Seconds	00-99	
01h	ST	10 Seconds			Seconds					Seconds	00-59
02h	OFIE	10 Minutes			Minutes					Minutes	00-59
03h	0	0	10 Hours		Hours (24 Hour Format)				Hours	00-23	
04h	0	0	0	0	0	Day of Week			Day	01-7	
05h	0	0	10 Date		Date: Day of Month				Date	01-31	
06h	CB1	CB0	0	10M	Month				Century/ Month	0-3/01-12	
07h	10 Years				Year				Year	00-99	
08h	OUT	FT	S	Calibration					Calibration		
09h	RB2	BMB4	BMB3	BMB2	BMB1	BMB0	RB1	RB0	Watchdog		
0Ah	AFE	0	0	AI 10M	Alarm Month				AI Month	01-12	
0Bh	RPT4	RPT5	AI 10 Date		Alarm Date				AI Date	01-31	
0Ch	RPT3	0	AI 10 Hour		Alarm Hour				AI Hour	00-23	
0Dh	RPT2	Alarm 10 Minutes			Alarm Minutes				AI Min	00-59	
0Eh	RPT1	Alarm 10 Seconds			Alarm Seconds				AI Sec	00-59	
0Fh	WDF	AF	0	0	0	OF	0	0	Flags		

Keys: 0 = Must be set to '0'

AF = Alarm Flag (Read only)
 AFE = Alarm Flag Enable Flag
 BMB0 - BMB4 = Watchdog Multiplier Bits
 CB0-CB1 = Century Bits
 FT = Frequency Test Bit
 OF = Oscillator Fail Bit

OFIE = Oscillator Fail Interrupt Enable Bit
 OUT = Output level
 RB0 - RB2 = Watchdog Resolution Bits
 RPT1-RPT5 = Alarm Repeat Mode Bits
 S = Sign Bit
 ST = Stop Bit
 WDF = Watchdog Flag Bit (Read only)



Calibrating the Clock

The M41T6X is driven by a quartz controlled oscillator with a nominal frequency of 32,768Hz. The accuracy of the Real-Time Clock depends on the frequency of the quartz crystal that is used as the time-base for the RTC. The M41T6X is tested to meet ± 35 ppm (parts per million) oscillator frequency error at 25°C, with a nominal crystal (see Note 1 of Table 12., page 24). When the Calibration circuit is properly employed, accuracy improves to better than ± 2 ppm at 25°C.

The oscillation rate of crystals changes with temperature (see Figure 20., page 18). Therefore, the M41T6X design employs periodic counter correction. The calibration circuit adds or subtracts counts from the oscillator divider circuit at the divide by 256 stage, as shown in Figure 21., page 18. The number of times pulses which are blanked (subtracted, negative calibration) or split (added, positive calibration) depends upon the value loaded into the five Calibration Bits found in the Calibration Register. Adding counts speeds the clock up, subtracting counts slows the clock down.

The Calibration Bits occupy the five lower order bits (D4-D0) in the Calibration Register (08h). These bits can be set to represent any value between 0 and 31 in binary form. Bit D5 is a Sign Bit; '1' indicates positive calibration, '0' indicates negative calibration. Calibration occurs within a 64 minute cycle. The first 62 minutes in the cycle may, once per minute, have one second either shortened by 128 or lengthened by 256 oscillator cycles. If a binary '1' is loaded into the register, only the first 2 minutes in the 64 minute cycle will be modified; if a binary 6 is loaded, the first 12 will be affected, and so on.

Therefore, each calibration step has the effect of adding 512 or subtracting 256 oscillator cycles for every 125,829,120 actual oscillator cycles, that is +4.068 or -2.034 PPM of adjustment per calibration step in the calibration register.

Assuming that the oscillator is running at exactly 32,768 Hz, each of the 31 increments in the Calibration byte would represent +10.7 or -5.35 seconds per day which corresponds to a total range of +5.5 or -2.75 minutes per month (see Figure 21., page 18).

Two methods are available for ascertaining how much calibration a given M41T6X may require:

- The first involves setting the clock, letting it run for a month and comparing it to a known accurate reference and recording deviation over a fixed period of time. Calibration values, including the number of seconds lost or gained in a given period, can be found in Application Note AN934, "TIMEKEEPER[®] CALIBRATION." This allows the designer to give the end user the ability to calibrate the clock as the environment requires, even if the final product is packaged in a non-user serviceable enclosure. The designer could provide a simple utility that accesses the Calibration byte.
- The second approach is better suited to a manufacturing environment, and involves the use of either the SQW pin (M41T62/63/64) or the IRQ/FT/OUT pin (M41T65). The SQW pin will toggle at 512Hz when RS3 = '0,' RS2 = '1,' RS1 = '1,' RS0 = '0,' SQWE = '1,' and ST = '0.' Alternatively, for the M41T65, the IRQ/FT/OUT pin will toggle at 512Hz when FT and OUT Bits = '1' and ST = '0.'

Any deviation from 512Hz indicates the degree and direction of oscillator frequency shift at the test temperature. For example, a reading of 512.010124 Hz would indicate a +20 ppm oscillator frequency error, requiring a -10 (XX001010) to be loaded into the Calibration Byte for correction. Note that setting or changing the Calibration Byte does not affect the Frequency test or Square Wave output frequency.

Figure 20. Crystal Accuracy Across Temperature

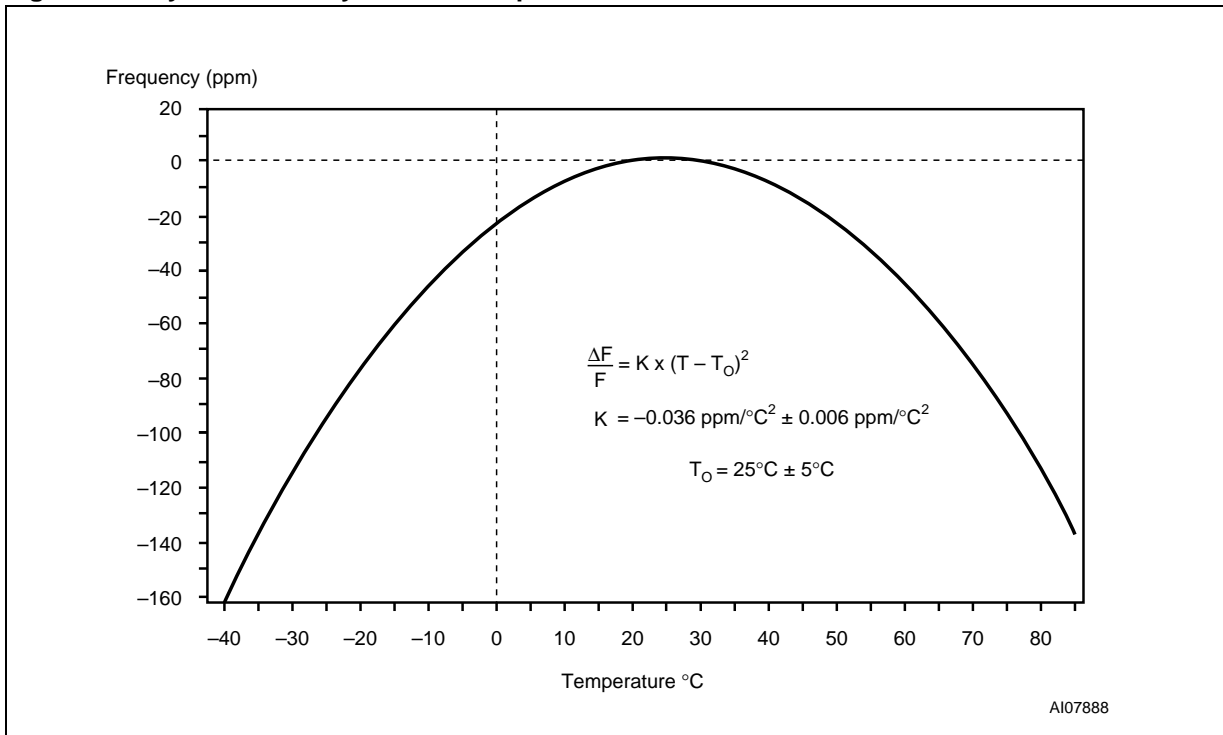
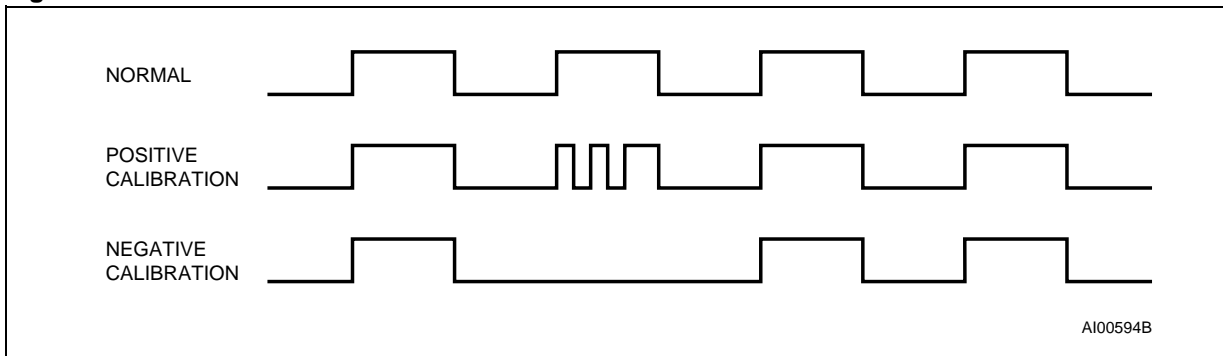

Figure 21. Calibration Waveform



Setting Alarm Clock Registers

Address locations 0Ah-0Eh contain the alarm settings. The alarm can be configured to go off at a prescribed time on a specific month, date, hour, minute, or second, or repeat every year, month, day, hour, minute, or second. Bits RPT5–RPT1 put the alarm in the repeat mode of operation. Table 7., page 19 shows the possible configurations. Codes not listed in the table default to the once per second mode to quickly alert the user of an incorrect alarm setting.

When the clock information matches the alarm clock settings based on the match criteria defined by RPT5–RPT1, the AF (Alarm Flag) is set. If AFE (Alarm Flag Enable) is also set (M41T62/65), the alarm condition activates the $\overline{\text{IRQ}}/\text{OUT}$ or $\overline{\text{IRQ}}/\text{FT}/\text{OUT}$ pin. To disable the alarm, write '0' to the Alarm Date Register and to RPT5–RPT1.

Note: If the address pointer is allowed to increment to the Flag Register address, an alarm condition will not cause the Interrupt/Flag to occur until the address pointer is moved to a different address. It should also be noted that if the last address written is the “Alarm Seconds,” the address pointer will increment to the Flag address, causing this situation to occur.

The $\overline{\text{IRQ}}$ output is cleared by a READ to the Flags Register as shown in Figure 22., page 19. A subsequent READ of the Flags Register is necessary to see that the value of the Alarm Flag has been reset to '0.'

Figure 22. Alarm Interrupt Reset Waveform

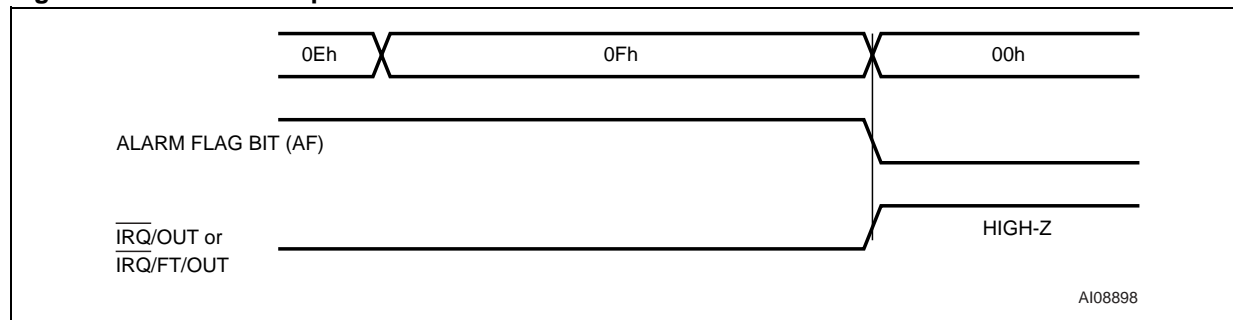

Table 7. Alarm Repeat Modes

RPT5	RPT4	RPT3	RPT2	RPT1	Alarm Setting
1	1	1	1	1	Once per Second
1	1	1	1	0	Once per Minute
1	1	1	0	0	Once per Hour
1	1	0	0	0	Once per Day
1	0	0	0	0	Once per Month
0	0	0	0	0	Once per Year

Watchdog Timer

The watchdog timer can be used to detect an out-of-control microprocessor. The user programs the watchdog timer by setting the desired amount of time-out into the Watchdog Register, address 09h.

Bits BMB4-BMB0 store a binary multiplier and the three bits RB2-RB0 select the resolution where:

000=1/16 second (16Hz);

001=1/4 second (4Hz);

010=1 second (1Hz);

011=4 seconds (1/4Hz); and

100 = 1 minute (1/60Hz).

Note: Invalid combinations (101, 110, and 111) will NOT enable a watchdog time-out. Setting the BMB4-BMB0 = 0 with any combination of RB2-RB0, other than 000, will result in an immediate watchdog time-out.

The amount of time-out is then determined to be the multiplication of the five-bit multiplier value with the resolution. (For example: writing 00001110 in the Watchdog Register = 3*1 or 3 seconds). If the processor does not reset the timer within the specified period, the M41T6X sets the WDF (Watchdog Flag) and generates an interrupt on the IRQ pin (M41T62), or a watchdog_output pulse (M41T63 and M41T65 only) on the WDO pin. The watchdog timer can only be reset by having the microproces-

sor perform a WRITE of the Watchdog Register. The time-out period then starts over.

Should the watchdog timer time-out, any value may be written to the Watchdog Register in order to clear the IRQ pin. A value of 00h will disable the watchdog function until it is again programmed to a new value. A READ of the Flags Register will reset the Watchdog Flag (Bit D7; Register 0Fh). The watchdog function is automatically disabled upon power-up, and the Watchdog Register is cleared.

Note: A WRITE to any clock register will restart the watchdog timer.

Watchdog Output (WDO - M41T63/65 only)

If the processor does not reset the watchdog timer within the specified period, the Watchdog Output (WDO) will pulse low for t_{rec} (see Table 16., page 26). This output may be connected to the Reset input of the processor in order to generate a processor reset. After a watchdog time-out occurs, the timer will remain disabled until such time as a new countdown value is written into the watchdog register.

Note: The crystal oscillator must be running for the WDO pulse to be available.

The WDO output is an N-channel, open drain output driver (with I_{OL} as specified in Table 14., page 25).

Square Wave Output (M41T62/63/64)

The M41T62/63/64 offers the user a programmable square wave function which is output on the SQW pin. RS3-RS0 bits located in 04h establish the square wave output frequency. These frequencies are listed in Table 8. Once the selection of the SQW frequency has been completed, the SQW pin can be turned on and off under software control with the Square Wave Enable Bit (SQWE) located in Register 0Ah.

The SQW output is an N-channel, open drain output driver for the M41T64, and a full CMOS output driver for the M41T62/63. The initial power-up default for the SQW output is 32KHz (except for M41T64, which defaults disabled).

Table 8. Square Wave Output Frequency

Square Wave Bits				Square Wave	
RS3	RS2	RS1	RS0	Frequency	Units
0	0	0	0	None	–
0	0	0	1	32.768	KHz
0	0	1	0	8.192	KHz
0	0	1	1	4.096	KHz
0	1	0	0	2.048	KHz
0	1	0	1	1.024	KHz
0	1	1	0	512	Hz
0	1	1	1	256	Hz
1	0	0	0	128	Hz
1	0	0	1	64	Hz
1	0	1	0	32	Hz
1	0	1	1	16	Hz
1	1	0	0	8	Hz
1	1	0	1	4	Hz
1	1	1	0	2	Hz
1	1	1	1	1	Hz

Full-time 32KHz Square Wave Output (M41T64)

The M41T64 offers the user a special 32KHz square wave function which is enabled on power-up to output on the F_{32k} pin as long as V_{CC} ≥ 1.3V, and the oscillator is running (ST Bit = '0'). This function is available within one second (typ) of ini-

tial power-up and can only be disabled by setting the 32kE Bit to '0' or the ST Bit to '1.' If not used, the F_{32k} pin should be disconnected and allowed to float.

Century Bits

These two bits will increment in a binary fashion at the turn of the century, and handle all leap years correctly. See Table 10., page 22 for additional explanation.

Output Driver Pin (M41T62/65)

When the OFIE Bit, AFE Bit, and watchdog register are not set to generate an interrupt, the IRQ/OUT pin becomes an output driver that reflects the contents of D7 of the Calibration Register. In other words, when D7 (OUT Bit) is a '0,' then the IRQ/OUT pin will be driven low.

Note: The IRQ/OUT pin is an open drain which requires an external pull-up resistor.

Oscillator Stop Detection

If the Oscillator Fail (OF) Bit is internally set to a '1,' this indicates that the oscillator has either stopped, or was stopped for some period of time and can be used to judge the validity of the clock and date data. This bit will be set to '1' any time the oscillator stops.

In the event the OF Bit is found to be set to '1' at any time other than the initial power-up, the STOP Bit (ST) should be written to a '1,' then immediately reset to '0.' This will restart the oscillator.

The following conditions can cause the OF Bit to be set:

- The first time power is applied (defaults to a '1' on power-up).
- **Note:** If the OF Bit cannot be written to '1' four (4) seconds after the initial power-up, the STOP Bit (ST) should be written to a '1,' then immediately reset to '0.'
- The voltage present on V_{CC} or battery is insufficient to support oscillation.
- The ST Bit is set to '1.'
- External interference of the crystal

If the Oscillator Fail Interrupt Enable Bit (OFIE) is set to a '1,' the IRQ pin will also be activated. The IRQ output is cleared by resetting the OFIE or OF Bit to '0' (NOT by reading the Flag Register).

The OF Bit will remain set to '1' until written to logic '0.' The oscillator must start and have run for at least 4 seconds before attempting to reset the OF Bit to '0.' If the trigger event occurs during a power-down condition, this bit will be set correctly.

Initial Power-on Defaults

Upon application of power to the device, the register bits will initially power-on in the state indicated in Table 9.

Table 9. Initial Power-on Default Values

Condition	Device	ST	OF	OFIE	OUT	FT	AFE	SQWE	32kE	RS3-1	RS0	Watchdog
Initial Power-up ⁽¹⁾	M41T62	0	1	0	1	N/A	0	1	N/A	0	1	0
	M41T63	0	1	N/A	N/A	N/A	N/A	1	N/A	0	1	0
	M41T64	0	1	N/A	N/A	N/A	N/A	0	1	0	1	0
	M41T65	0	1	0	1	0	0	N/A	N/A	N/A	N/A	0

Note: 1. All other control bits power-up in an undetermined state.

Table 10. Century Bits Examples

CB0	CB1	Leap Year?	Example ⁽¹⁾
0	0	Yes	2000
0	1	No	2100
1	0	No	2200
1	1	No	2300

Note: 1. Leap year occurs every four years (for years evenly divisible by four), except for years evenly divisible by 100. The only exceptions are those years evenly divisible by 400 (the year 2000 was a leap year, year 2100 is not).

MAXIMUM RATING

Stressing the device above the rating listed in the “Absolute Maximum Ratings” table may cause permanent damage to the device. These are stress ratings only and operation of the device at these or any other conditions above those indicated in the Operating sections of this specification is

not implied. Exposure to Absolute Maximum Rating conditions for extended periods may affect device reliability. Refer also to the STMicroelectronics SURE Program and other relevant quality documents.

Table 11. Absolute Maximum Ratings

Sym	Parameter	Value	Unit
T _{STG}	Storage Temperature (V _{CC} Off, Oscillator Off)	–55 to 125	°C
V _{CC}	Supply Voltage	–0.3 to 4.6	V
T _{SLD} ⁽¹⁾	Lead Solder Temperature for 10 Seconds	260	°C
V _{IO}	Input or Output Voltages	–0.2 to V _{CC} +0.2	V
I _O	Output Current	20	mA
P _D	Power Dissipation	1	W

Note: 1. Reflow at peak temperature of 260°C (total thermal budget not to exceed 245°C for greater than 30 seconds).

DC AND AC PARAMETERS

This section summarizes the operating and measurement conditions, as well as the DC and AC characteristics of the device. The parameters in the following DC and AC Characteristic tables are derived from tests performed under the Measure-

ment Conditions listed in the relevant tables. Designers should check that the operating conditions in their projects match the measurement conditions when using the quoted parameters.

Table 12. Operating and AC Measurement Conditions

Parameter	M41T6X
Supply Voltage (V _{CC})	1.3V to 3.6V
Ambient Operating Temperature (T _A)	-40 to 85°C
Load Capacitance (C _L)	50pF
Input Rise and Fall Times	≤ 50ns
Input Pulse Voltages	0.2V _{CC} to 0.8 V _{CC}
Input and Output Timing Ref. Voltages	0.3V _{CC} to 0.7 V _{CC}

Note: Output Hi-Z is defined as the point where data is no longer driven.

Figure 23. AC Measurement I/O Waveform

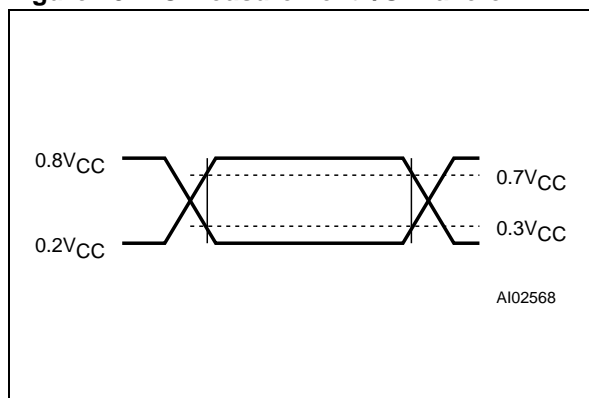
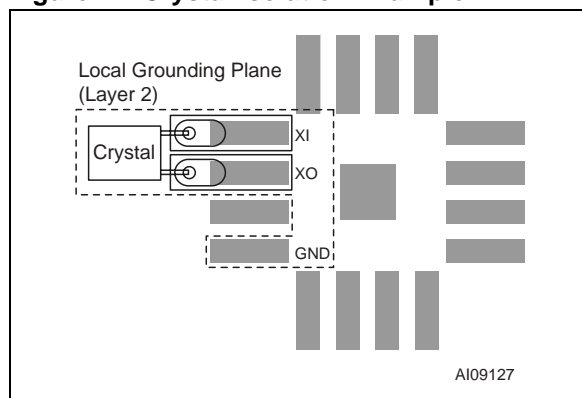

Figure 24. Crystal Isolation Example



Note: Substrate pad should be tied to V_{SS}.

Table 13. Capacitance

Symbol	Parameter ^(1,2)	Min	Max	Unit
C _{IN}	Input Capacitance		7	pF
C _{OUT} ⁽³⁾	Output Capacitance		10	pF
t _{LP}	Low-pass filter input time constant (SDA and SCL)		50	ns

Note: 1. Effective capacitance measured with power supply at 3.6V; sampled only, not 100% tested.
 2. At 25°C, f = 1MHz.
 3. Outputs deselected.

Table 14. DC Characteristics

Symbol	Parameter	Test Condition ⁽¹⁾		Min	Typ	Max	Unit
V _{CC} ⁽³⁾	Operating Voltage	Clock ⁽²⁾		1.0		3.6	V
		I ² C bus (400KHz)		1.3		3.6	V
I _{CC1}	Supply Current	SCL = 400KHz (No load)		V _{CC} = 3.6V		400	μA
				V _{CC} = 3.0V		350	μA
				V _{CC} = 2.5V		300	μA
				V _{CC} = 2.0V		250	μA
I _{CC2}	Supply Current (standby)	SCL = 0Hz All inputs ≥ V _{CC} - 0.2V ≤ V _{SS} + 0.2V	SQW On (Open Drain)	3.6V		1.3	μA
				3.0V		1.2	μA
				2.0V		0.9	μA
			SQW Off	3.6V		0.7	μA
				3.0V		0.65	μA
				2.0V		0.6	μA
I _{OSC}	Oscillator Current	@ 25°C		V _{CC} = 3.0V	0.3	0.5	μA
		-40°C to 85°C					μA
V _{IL}	Input Low Voltage			-0.2		0.3V _{CC}	V
V _{IH}	Input High Voltage			0.7V _{CC}		V _{CC} +0.2	V
V _{OL}	Output Low Voltage	V _{CC} = 3.6V, I _{OL} = 3.0mA (CMOS or Open Drain)				0.4	V
		V _{CC} = 3.6V, I _{OL} = 1.0mA (SQW, WDO, IRQ)				0.4	V
V _{OH}	Output High Voltage	V _{CC} = 3.6V, I _{OL} = -1.0mA (Push-Pull)		2.4			V
	Pull-up Supply Voltage (Open Drain)	IRQ/OUT, IRQ/FT/OUT, WDO, SQW (M41T64 only)				3.6	V
I _{LI}	Input Leakage Current	0V ≤ V _{IN} ≤ V _{CC}				±1	μA
I _{LO}	Output Leakage Current	0V ≤ V _{OUT} ≤ V _{CC}				±1	μA

Note: 1. Valid for Ambient Operating Temperature: T_A = -40 to 85°C; V_{CC} = 1.3V to 3.6V (except where noted).
 2. Oscillator start-up guaranteed at 1.5V only.
 3. When using battery back-up, V_{CC} fall time should not exceed 10mV/μs.

Table 15. Crystal Electrical Characteristics

Sym	Parameter ^(1,2)	Min	Typ	Max	Units
f ₀	Resonant Frequency		32.768		KHz
R _S	Series Resistance			60 ⁽³⁾	kΩ
C _L	Load Capacitance		6		pF

Note: 1. Externally supplied if using the QFN16 package. STMicroelectronics recommends the Citizen CFS-145 (1.5x5mm) and the KDS DT-38 (3x8mm) for thru-hole, or the KDS DMX-26S (3.2x8mm) for surface-mount, tuning fork-type quartz crystals.

KDS can be contacted at kouhou@kdsj.co.jp or <http://www.kdsj.co.jp>.

Citizen can be contacted at csd@citizen-america.com or <http://www.citizen-crystal.com>.

- Load capacitors are integrated within the M41T6X. Circuit board layout considerations for the 32.768 KHz crystal of minimum trace lengths and isolation from RF generating signals should be taken into account.
- Guaranteed by design.

Figure 25. Bus Timing Requirements Sequence

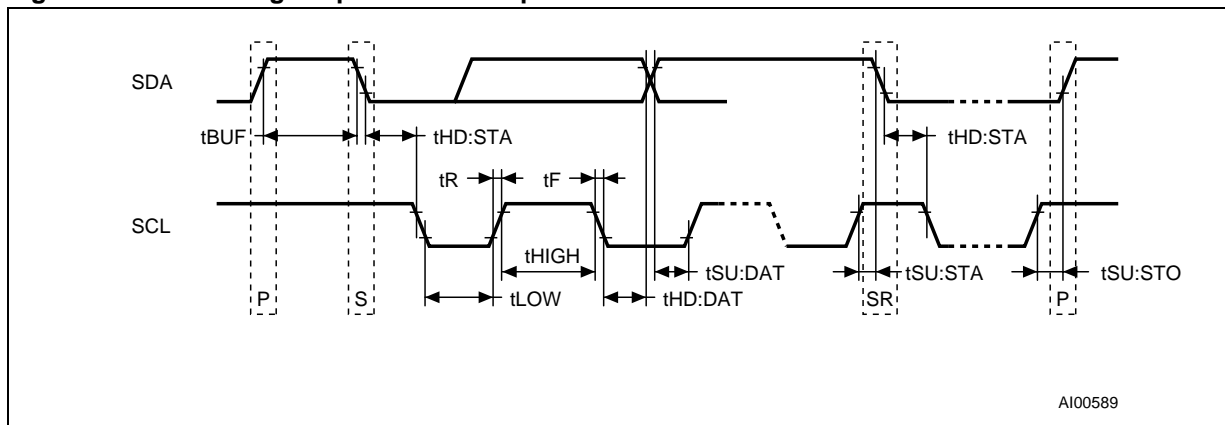

A100589

Table 16. AC Characteristics

Sym	Parameter ⁽¹⁾	Min	Typ	Max	Units
f _{SCL}	SCL Clock Frequency	0		400	KHz
t _{LOW}	Clock Low Period	1.3			µs
t _{HIGH}	Clock High Period	600			ns
t _R	SDA and SCL Rise Time			300	ns
t _F	SDA and SCL Fall Time			300	ns
t _{HD:STA}	START Condition Hold Time (after this period the first clock pulse is generated)	600			ns
t _{SU:STA}	START Condition Setup Time (only relevant for a repeated start condition)	600			ns
t _{SU:DAT} ⁽²⁾	Data Setup Time	100			ns
t _{HD:DAT}	Data Hold Time	0			µs
t _{SU:STO}	STOP Condition Setup Time	600			ns
t _{BUF}	Time the bus must be free before a new transmission can start	1.3			µs
t _{rec}	Watchdog Output Pulse Width	96		98	ms

Note: 1. Valid for Ambient Operating Temperature: T_A = -40 to 85°C; V_{CC} = 1.3 to 3.6V (except where noted).
 2. Transmitter must internally provide a hold time to bridge the undefined region (300ns max) of the falling edge of SCL.

PACKAGE MECHANICAL INFORMATION

Figure 26. QFN16 – 16-lead, Quad, Flat Package, No Lead, 3x3mm body size, Outline

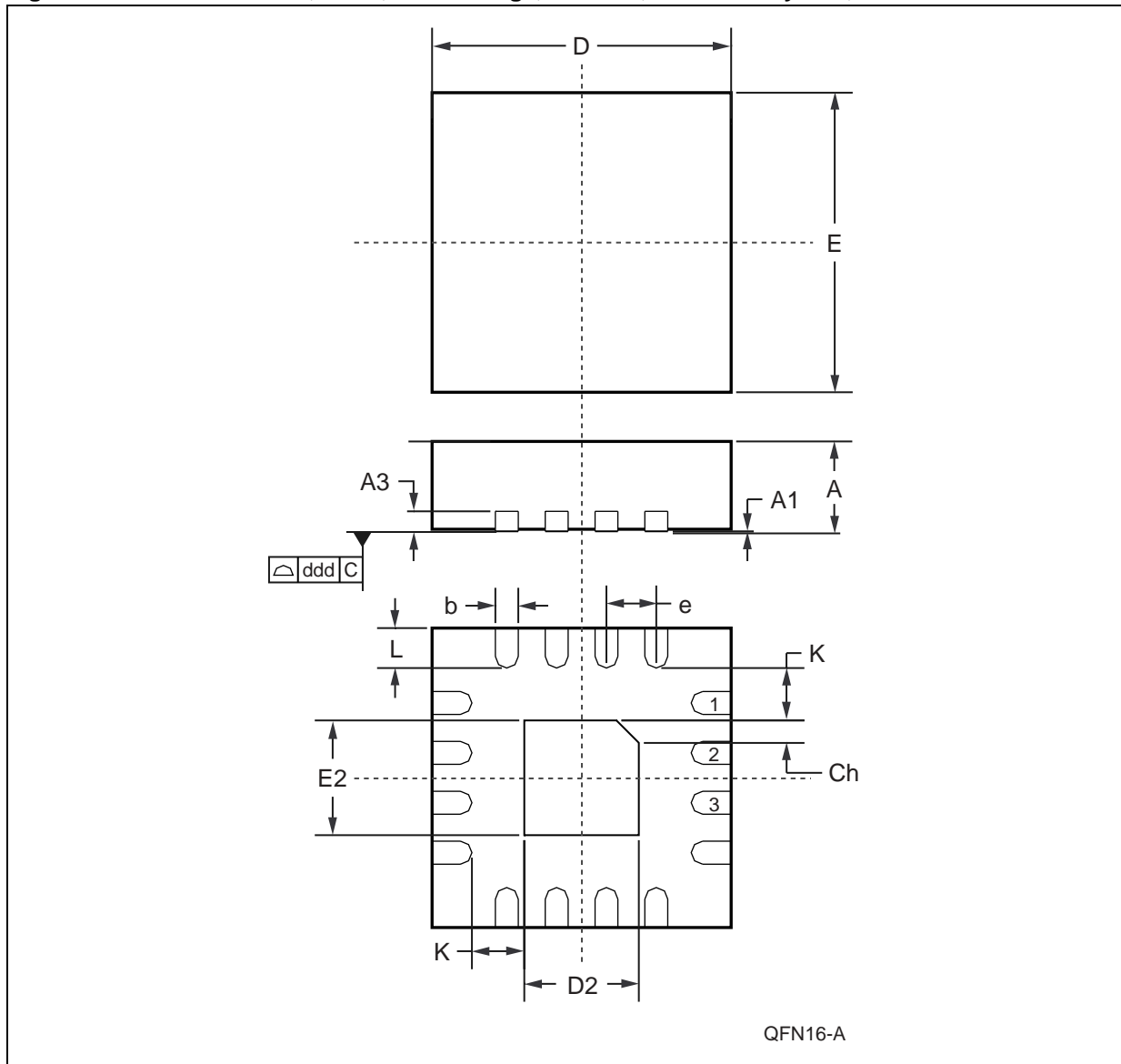

Note: Drawing is not to scale.

Table 17. QFN16 – 16-lead, Quad, Flat Package, No Lead, 3x3mm body size, Mechanical Data

Symb	mm			inches		
	Typ	Min	Max	Typ	Min	Max
A	0.90	0.80	1.00	0.035	0.032	0.039
A1	0.02	0.00	0.05	0.001	0.000	0.002
A3	0.20	–	–	0.008	–	–
b	0.25	0.18	0.30	0.010	0.007	0.012
D	3.00	2.90	3.10	0.118	0.114	0.122
D2	1.70	1.55	1.80	0.067	0.061	0.071
E	3.00	2.90	3.10	0.118	0.114	0.122
E2	1.70	1.55	1.80	0.067	0.061	0.071
e	0.50	–	–	0.020	–	–
K	0.20	–	–	0.008	–	–
L	0.40	0.30	0.50	0.016	0.012	0.020
ddd	–	0.08	–	–	0.003	–
Ch	–	0.33	–	–	0.013	–
N	16			16		

Figure 27. QFN16 – 16-lead, Quad, Flat Package, No Lead, 3x3mm body size, Footprint

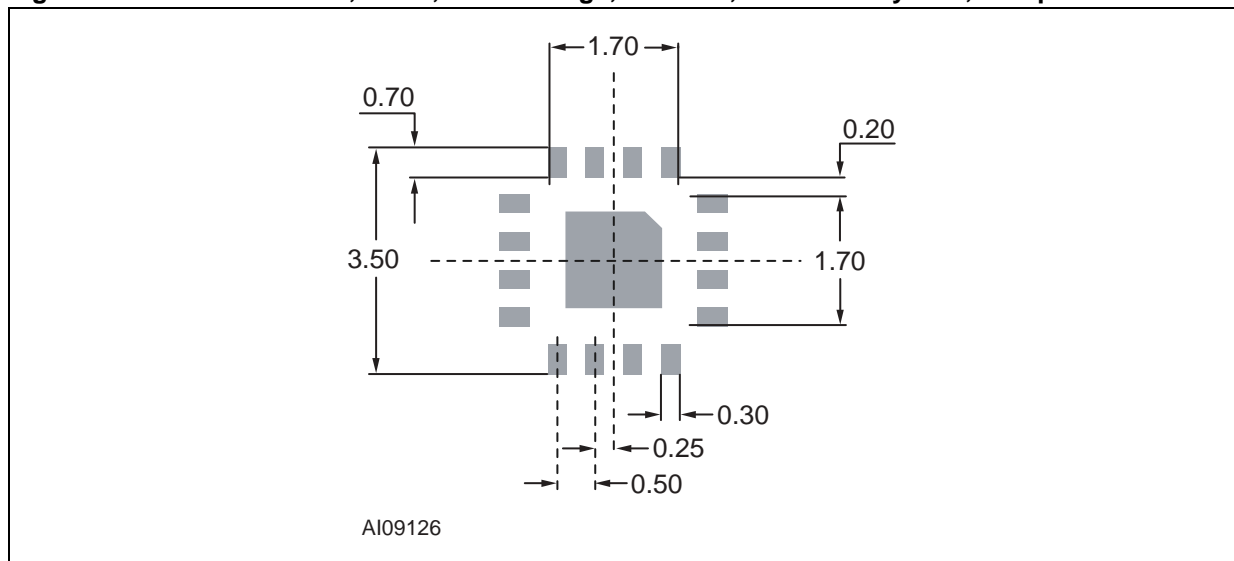

PART NUMBERING

Table 18. Ordering Information Scheme

Example:	M41T	62	Q	6	F
Device Family	M41T				
Device Type and Supply Voltage		62 = $V_{CC} = 1.3V$ to 3.6V 63 = $V_{CC} = 1.3V$ to 3.6V 64 = $V_{CC} = 1.3V$ to 3.6V 65 = $V_{CC} = 1.3V$ to 3.6V			
Package			Q = QFN16		
Temperature Range				6 = $-40^{\circ}C$ to $85^{\circ}C$	
Shipping Method for SOIC					F = Lead-free Package (ECO [®] PACK [®]), Tape & Reel

For other options, or for more information on any aspect of this device, please contact the ST Sales Office nearest you.

REVISION HISTORY**Table 19. Document Revision History**

Date	Version	Revision Details
November 13, 2003	1.0	First Issue
19-Nov-03	1.1	Add features, update characteristics (Figure 2, 3, 5, 10, 22; Table 2, 3, 9, 11, 14, 16)
25-Dec-03	2.0	Reformatted; add crystal isolation, footprint (Figure 24)
14-Jan-04	2.1	Update characteristics (Figure 2, 10, 24; Table 1, 3, 9, 14)
27-Feb-04	2.2	Update characteristics and mechanical dimensions (Figure 2, 3, 4, 5, 6, 7, 10, 11, 12, 13, 26, 27; Table 3, 4, 5, 6, 9, 11, 14, 17)
02-Mar-04	2.3	Update characteristics (Figure 8, 9, 12; Table 2, 14)
26-Apr-04	3.0	Reformat and republish
13-May-04	4.0	Update characteristics (Figure 6, 7, 8, 9, 24, 27; Table 11, 14, 15)

Information furnished is believed to be accurate and reliable. However, STMicroelectronics assumes no responsibility for the consequences of use of such information nor for any infringement of patents or other rights of third parties which may result from its use. No license is granted by implication or otherwise under any patent or patent rights of STMicroelectronics. Specifications mentioned in this publication are subject to change without notice. This publication supersedes and replaces all information previously supplied. STMicroelectronics products are not authorized for use as critical components in life support devices or systems without express written approval of STMicroelectronics.

The ST logo is a registered trademark of STMicroelectronics.

All other names are the property of their respective owners.

© 2004 STMicroelectronics - All rights reserved

STMicroelectronics GROUP OF COMPANIES
Australia - Belgium - Brazil - Canada - China - Czech Republic - Finland - France - Germany -
Hong Kong - India - Israel - Italy - Japan - Malaysia - Malta - Morocco - Singapore -
Spain - Sweden - Switzerland - United Kingdom - United States
www.st.com