

T-41-31

SIEMENS

SUPER RED OLB 2655

YELLOW YLB 2755

GREEN GLB 2855

LIGHT BARS

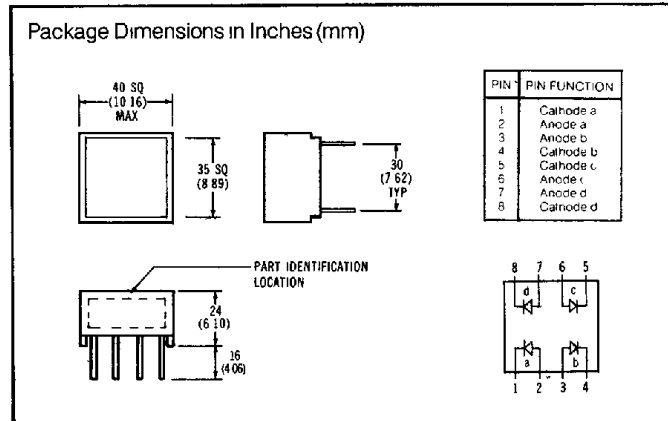
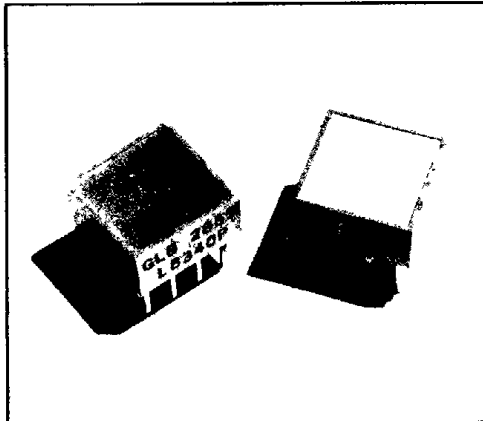

Num. Displays
Bar Graphs
Light Bars

FEATURES

- Square Package
- Uniform Light Emitting Area
- Excellent ON/OFF Contrast
- Choice of Three Colors
- Categorized for Light Output
- Yellow and Green Categorized for Dominant Wavelength
- Panel or Legend Mountable
- Can be Mounted on P.C. Boards or DIP Sockets
- X-Y Stackable
- Suitable for Multiplexing
- IC Compatible

APPLICATIONS

These devices are ideally suited for:

- Message Annunciators
- Positions/Status Indicators
- Telecommunications Indicators
- Bar Graphs

DESCRIPTION

The OLB 2655/YLB 2755/GLB 2855 series light bars are square displays designed for application requiring a large light emitting area. They are configured in a dual in-line package and contain a single light emitting area. The OLB 2655 and YLB 2755 devices utilize four LED chips which are made from GaAsP on a transparent GaP substrate. The GLB 2855 device utilizes four chips made from GaP on a transparent GaP substrate.

Maximum Ratings

	OLB 2655 & GLB 2855	YLB 2755
Average Power Dissipation per LED chip	135mW	85mW
Peak Forward Current per LED chip Ta = 50°C (max pulse width = 2ms)	90mA	60mA
Average Forward Current per LED	25mA	20mA
Pulsed conditions (Ta = 50°C)		
DC Forward Current Per LED (Ta = 50°C)	30mA	25mA
Reverse Voltage per LED chip	6V	
Operating Temperature	-40°C to +85°C	
Storage Temperature	-40°C to +85°C	
Lead Soldering Temperature, 1/16 inch below seating plane	260°C for 3 sec	
Junction Temperature	100°C	

Electrical/Optical Characteristics (@ 25°C)

Parameters	Min.	Typ.	Max.	Units	Test Conditions
Luminous Intensity					
OLB2655	9	20		mcd	20mA DC
YLB2755	8	12		mcd	20mA DC
GLB2855	7.5	20		mcd	20mA DC
Peak Wavelength				nm	
OLB2655		635		nm	
YLB2755		583		nm	
GLB2855		565		nm	
Dominant Wavelength				nm	
OLB2655		626		nm	
YLB2755		585		nm	
GLB2855		572		nm	
Forward Voltage				V	
OLB2655		2.1	2.6	V	If = 20mA
YLB2755		2.2	2.6	V	If = 20mA
GLB2855		2.2	2.6	V	If = 20mA
Reverse Voltage				V	
OLB2655	6	15		V	IR = 100µA
YLB2755	6	15		V	IR = 100µA
GLB2855	6	15		V	IR = 100µA