



Details are subject to change without notice.

8+1-CHANNEL BUFFER FOR TFT LCD

FEATURES

- 8 Channels with Output Current: $\pm 30\text{mA}$ (MAX)
- 1 V_{com} with Output Current: $\pm 100\text{mA}$ (MAX)
- Unity Gain Buffer Capable of Driving Large Capacitive Loads
- Input Range Matched to LCD Reference Requirements
- Specified for -20°C to $+85^{\circ}\text{C}$...6.5V to 16V
- SSOP-24 Package

GENERAL DESCRIPTION

The AAT7205 is specially designed for thin film transistor liquid crystal display (TFT LCD). It is a buffer with 8+1 channels which delivers output current up to 30mA. This device is equipped with a V_{com} buffer circuit, two rail-to-rail buffer amplifier circuits, and 6 buffer amplifiers circuits. Each buffer is capable of driving heavy capacitive loads and offers fast load current (V_{com} : 100mA, the others: 30mA).

PIN CONFIGURATION

TOP VIEW

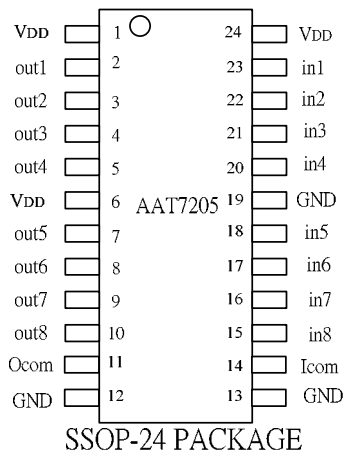

**PIN DESCRIPTION**

PIN NO.	NAME	I/O	DESCRIPTION
1	V _{DD}	I	Power Supply
2	out1	O	Buffer Channel 1 Output
3	out2	O	Buffer Channel 2 Output
4	out3	O	Buffer Channel 3 Output
5	out4	O	Buffer Channel 4 Output
6	V _{DD}	I	Power Supply
7	out5	O	Buffer Channel 5 Output
8	out6	O	Buffer Channel 6 Output
9	out7	O	Buffer Channel 7 Output
10	out8	O	Buffer Channel 8 Output
11	O _{com}	O	Com Buffer Output
12	GND	I	Ground
13	GND	I	Ground
14	I _{com}	I	Com Buffer Input
15	in8	I	Buffer Channel 8 Input
16	in7	I	Buffer Channel 7 Input
17	in6	I	Buffer Channel 6 Input
18	in5	I	Buffer Channel 5 Input
19	GND	I	Ground
20	in4	I	Buffer Channel 4 Input
21	in3	I	Buffer Channel 3 Input
22	in2	I	Buffer Channel 2 Input
23	in1	I	Buffer Channel 1 Input
24	V _{DD}	I	Power Supply

**ABSOLUTE MAXIMUM RATINGS**

CHARACTERISTICS	SYMBOL	VALUE	UNIT
Supply Voltage	V_{DD}	+18	V
Input Voltage	V_I	-0.5 to $V_{DD} + 0.5$	V
Output Voltage	V_O	-0.5 to $V_{DD} + 0.5$	V
Output Loading Current for Gamma Rail-to-Rail Buffer	I_L	± 30	mA
Output Loading Current for Com Buffer		± 100	mA
Maximum Junction Temperature	T_J	+125	°C
Operating Temperature	T_C	-20 to +85	°C
Storage Temperature	$T_{storage}$	-45 to +125	°C
Lead Temperature (Soldering for 10 Seconds)	---	260	°C

Note1: Values beyond absolute maximum ratings may cause permanent damage to the device.

**ELECTRICAL CHARACTERISTICS ($V_{DD}=10V$, $T_C=25^{\circ}C$ UNLESS OTHERWISE SPECIFIED)****POWER SUPPLY PERFORMANCE**

PARAMETER		TEST CONDITIONS	MIN	TYP	MAX	UNITS
Power Supply Rejection Ratio	PSRR	V_{DD} is Moved from 6.5V to 15.5V		80		dB
Supply Current	I_S			7.4		mA

INPUT CHARACTERISTICS

PARAMETER		TEST CONDITIONS	MIN	TYP	MAX	UNITS
Input Offset Voltage	V_{OS}	$V_I = V_{DD}/2$, $V_O = V_{DD}/2$		2	12	mV
Input Bias Current	I_B	$V_I = V_{DD}/2$, $V_O = V_{DD}/2$		2	50	nA



ELECTRICAL CHARACTERISTICS ($V_{DD}=10V$, $T_C=25^\circ C$ UNLESS OTHERWISE SPECIFIED) (CONT.)

OUTPUT CHARACTERISTICS

PARAMETER		TEST CONDITIONS	MIN	TYP	MAX	UNITS
Output Swing Low	V_{OL}	$I_L=5mA$ (Buffer 1,8) $V_I=0V$		0.08	0.15	V
		$I_L=10mA$ (Buffer 2,3,4,5,6,7) $V_I=1V$		1.02	1.05	V
Output Swing High	V_{OH}	$I_L=-5mA$ (Buffer 1,8) $V_I=10V$	9.85	9.92		V
		$I_L=-10mA$ (Buffer 2,3,4,5,6,7) $V_I=9V$	8.95	8.98		V
Output Swing (Buffer 2,3,4,5,6,7)	V_{OL}	$I_L=10mA$ $V_I=5V$		5.02	5.04	V
	V_{OH}	$I_L=-10mA$ $V_I=5V$	4.96	4.98		V
Output Swing (COM)	V_{OL}	$I_L=50mA$ $V_I=5V$		5.03	5.05	V
	V_{OH}	$I_L=-50mA$ $V_I=5V$	4.95	4.97		V
Short Circuit Current	I_{SC}	(Buffer 2~7)		± 70		mA
		(Com Buffer, Buffer1,8)		± 180		mA

AC Characteristics

Parameter		Test Conditions	Min	Typ	Max	Units
Slew Rate [Note 2]	SR	$V_I=2V$ to $8V$, 20% to 80%		1		V/ μs
Settling Time	t_s	$V_I=4.5V$ to $5.5V$ 0.1%		5		μs
		$V_I=5.5V$ to $4.5V$ 0.1%				

Note 2: Slew rate is measured on rising and falling edges.



BLOCK DIAGRAM

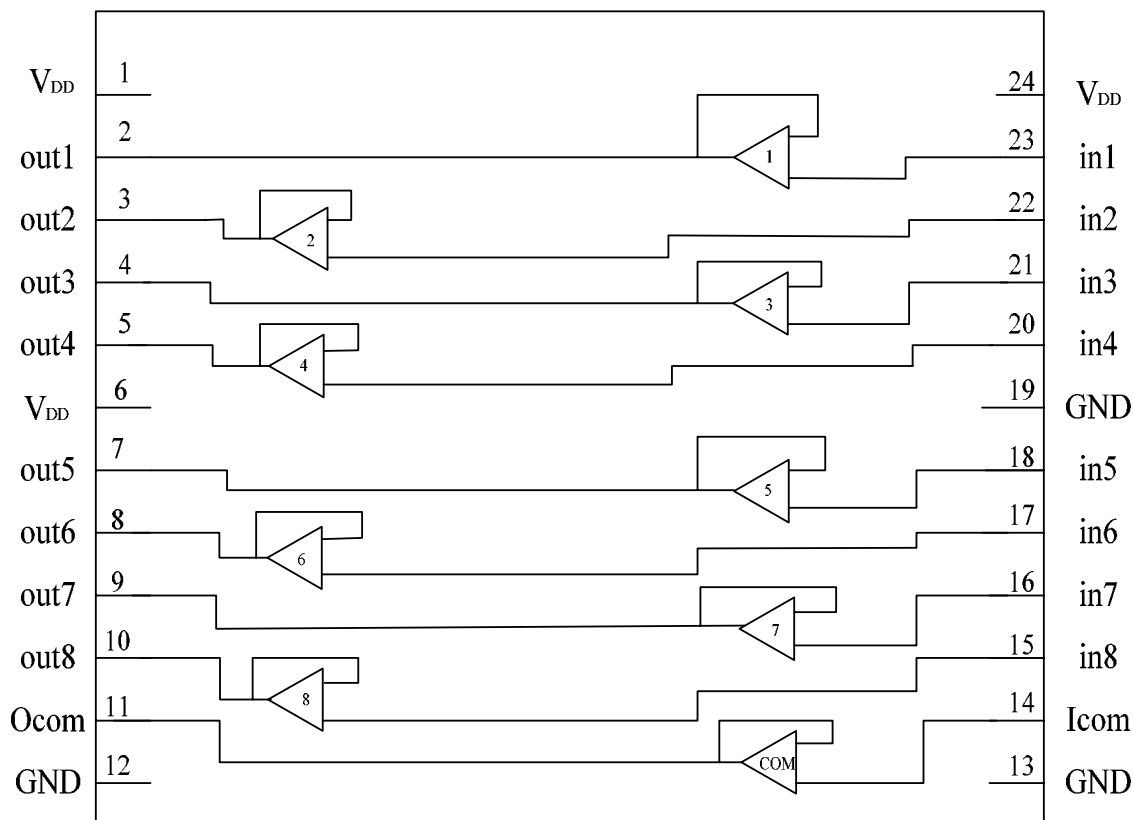



APPLICATION CIRCUIT

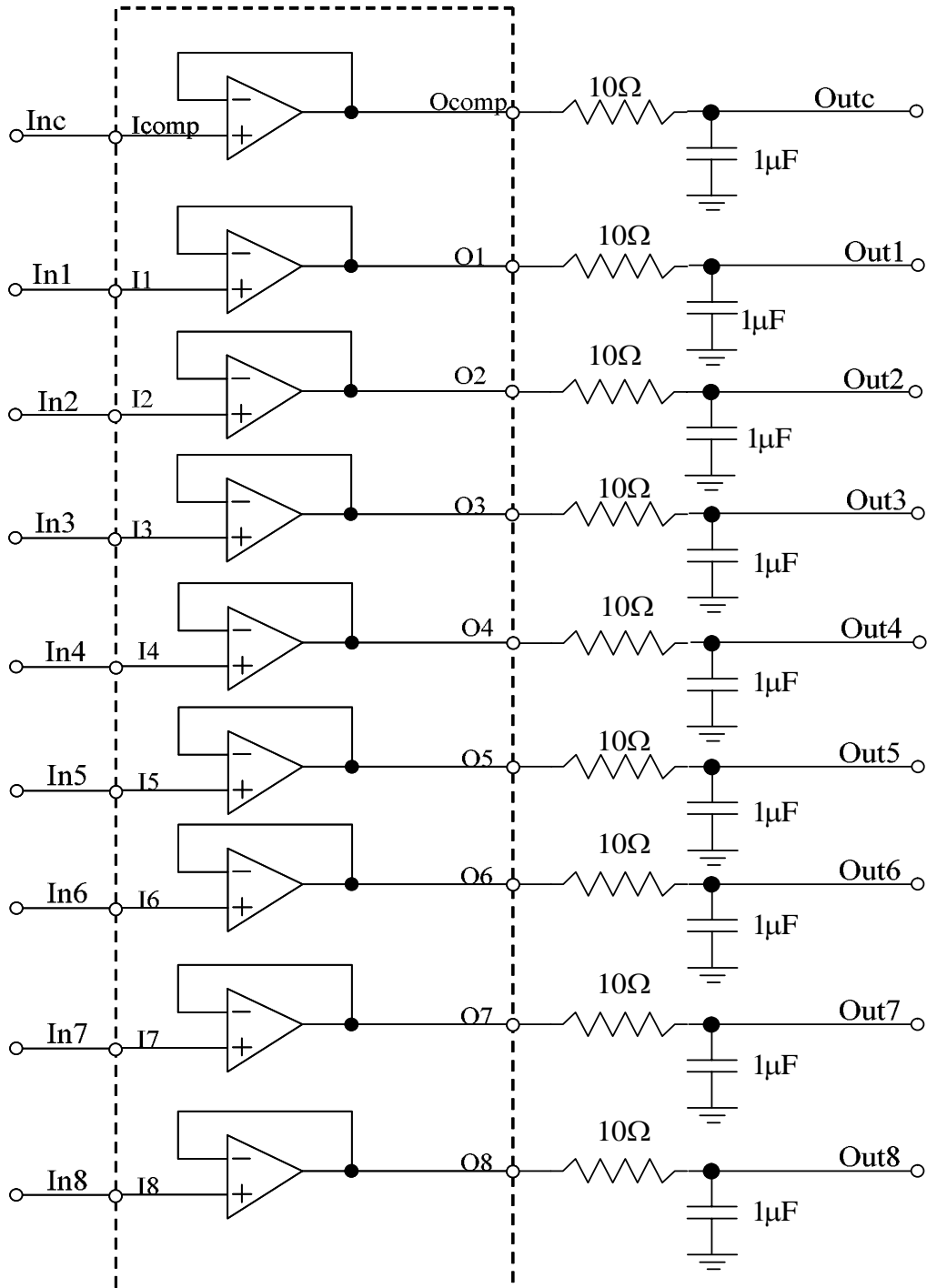



PACKAGE DIMENSION
SSOP-24 PACKAGE

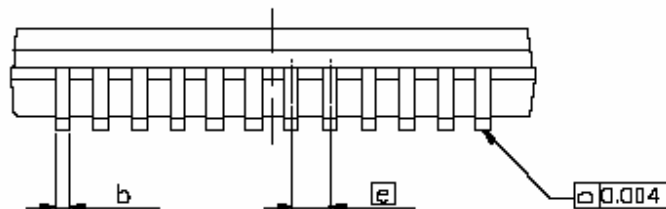
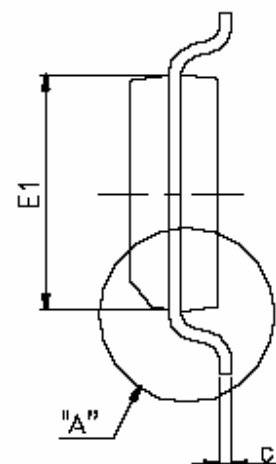
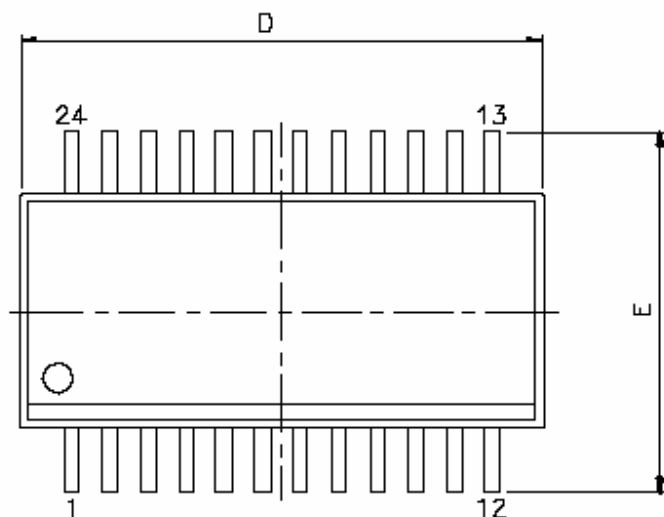



PACKAGE DIMENSION (CONT.)
SSOP-24 PACKAGE

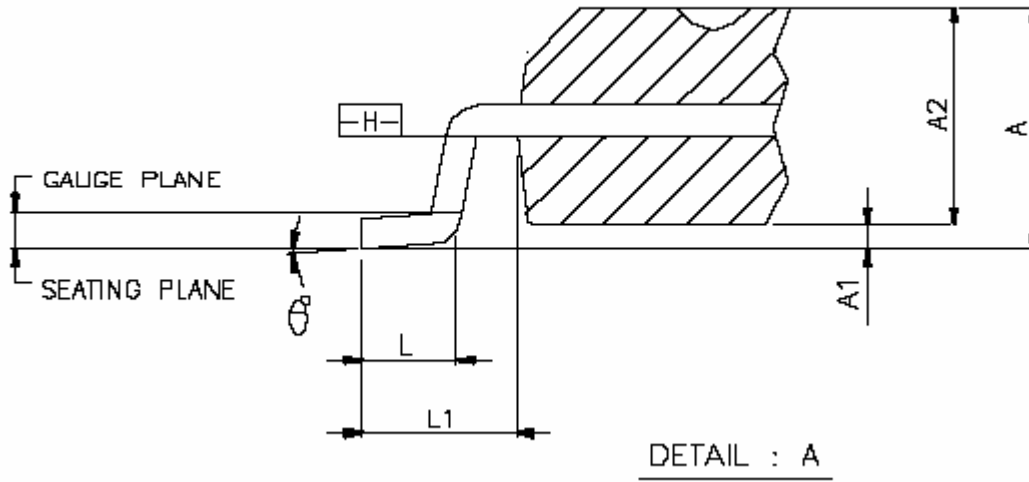

SYMBOL	DIMENSION IN INCHES		
	MIN	TYP	MAX
A	0.053	0.064	0.069
A1	0.004	0.006	0.010
A2	-	-	0.060
D	0.336	0.340	0.344
E	0.228	0.236	0.244
E1	0.150	0.154	0.157
b	0.008	-	0.012
C	0.007	-	0.010
e	0.025 BASIC		
L	0.015	0.025	0.050
L1	0.041 BASIC		
θ°	0°	-	8°

Note:

1. JEDEC OUTLINE: MO-137 AE
2. DIMENSION D DOES NOT INCLUDE MOLD PROTRUSIONS OR GATE BURRS. MOLD PROTRUSIONS AND GATE BURRS SHALL NOT EXCEED 0.006" PER SIDE. DIMENSION E1 DOES NOT INCLUDE INTERLEAD MOLD PROTRUSIONS. INTERLEAD MOLD PROTRUSIONS SHALL NOT EXCEED 0.010° PER SIDE.
3. DIMENSION b DOES NOT INCLUDE DAMBAR PROTRUSION/INTRUSION. ALLOWABLE DAMBAR PROTRUSION SHALL BE 0.004" TOTAL IN EXCESS OF b DIMENSION AT MAXIMUM MATERIAL CONDITION. DAMBAR INTRUSION SHALL NOT REDUCE DIMENSION b BY MORE THAN 0.002° AT LEAST.



ORDERING INFORMATION

AAT xxxxx-xx-x

AAT Part Number

Package Code 2
T=Taping Reel
Blank=Tube or Tray

Remark:
T=Taping Reel
PS.
Ssop24→2,500pcs/reel

Blank=Tube

Package Code 1
Ssop24: S11