

## FEATURES

- 10 - 500 MHz
- $\pm 1$  Deg. Phase Accuracy
- 0.3 mA, +5 VDC
- 1.0 dB Insertion Loss
- 35 nSec Transition Time
- 50 nSec Switching Speed
- 22 mV Transients
- TTL Control
- .530 Sq. Surface Mount Package



MODEL NO.  
DBP0738

## GaAs Bi-Phase Modulator

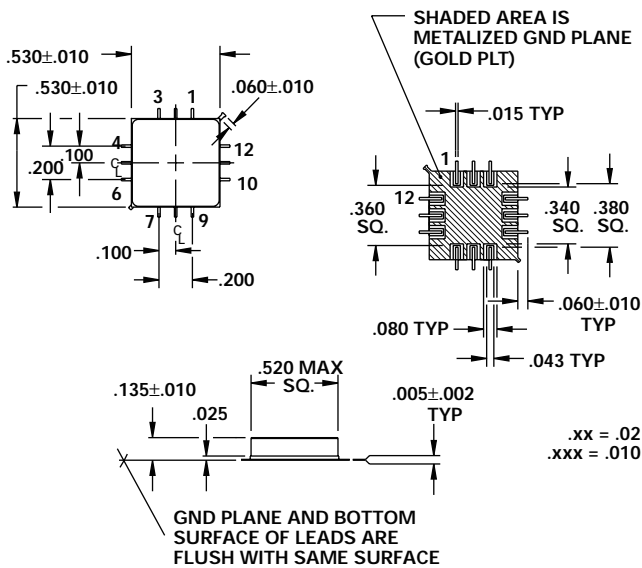
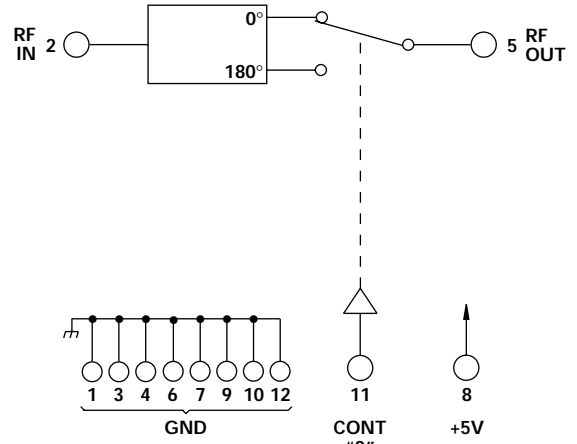

## GUARANTEED PERFORMANCE

Parameter	Min	Typ	Max	Units	Conditions
Operating Frequency	10		500	MHz	
DC Current		0.3	2.0	mA	At +5 VDC Supply
Control Type		TTL			1 Line Logic "1" = Phase Reversal
Control Current		0	$\pm 20$	$\mu$ A	$V_{IH} = +3.0$ V $V_{IL} = +0.6$ V
Insertion Loss		1.0	1.5	dB	10 - 100 MHz
		1.6	2.5	dB	100 - 500 MHz
Phase		180		DEG	
	Step Accuracy	$\pm 1.0$	$\pm 3.0$	DEG	
VSWR		1.28/1	1.4/1		
Impedance		50		OHMS	
Switching Speed		50	70	nSec	50% TTL to 90% / 10% RF
Transition (Rise/Fall) Time		35	50	nSec	90% / 10% or 10% / 90% RF
Switching (Video) Transients		22	50	mV	Peak Value
Intercept Points	2nd	+80		dBm	70 MHz / 50 MHz
	3rd	+51		dBm	35 MHz / 50 MHz
RF Power	Operate	+17	+13	dBm	0.1 dB Compression
	No Damage		+23	dBm	
Operating Temperature	-55	+25	+85	$^{\circ}$ C	TA

