



### GENERAL DESCRIPTION

The ICS8421002I-01 is a 2 output HSTL Synthesizer optimized to generate Ethernet reference clock frequencies and is a member of the HiPerClocks™ family of high performance clock solutions from ICS. Using a 25MHz, 18pF parallel resonant crystal, the following frequencies can be generated based on the 2 frequency select pins (F\_SEL[1:0]): 156.25MHz, 125MHz and 62.5MHz. The ICS8421002I-01 uses ICS' 3<sup>rd</sup> generation low phase noise VCO technology and can achieve 1ps or lower typical rms phase jitter, easily meeting Ethernet jitter requirements. The ICS8421002I-01 is packaged in a small 20-pin TSSOP package.

### FEATURES

- Two HSTL outputs (VOHmax = 1.5V)
- Selectable crystal oscillator interface or LVCMOS/LVTTL single-ended input
- Supports the following output frequencies: 156.25MHz, 125MHz, 62.5MHz
- VCO range: 560MHz - 680MHz
- RMS phase jitter @ 156.25MHz, using a 25MHz crystal (1.875MHz - 20MHz): 0.44ps (typical)
- Power supply modes:  
Core/Output  
3.3V/1.8V  
2.5V/1.8V
- -40°C to 85°C ambient operating temperature
- Available in both standard and lead-free RoHS compliant packages

FREQUENCY SELECT FUNCTION TABLE

F_SEL1	F_SEL0	M Divider Value	N Divider Value	Output Frequency (25MHz Ref.)
0	0	25	4	156.25
0	1	25	5	125
1	0	25	10	62.5
1	1	not used		not used

### PIN ASSIGNMENT

nc	1	20	VDD0
VDD0	2	19	Q1
Q0	3	18	nQ1
nQ0	4	17	GND
MR	5	16	VDD
nPLL_SEL	6	15	nXTAL_SEL
nc	7	14	REF_CLK
VDDA	8	13	XTAL_IN
F_SEL0	9	12	XTAL_OUT
VDD	10	11	F_SEL1

### ICS8421002I-01

#### 20-Lead TSSOP

6.5mm x 4.4mm x 0.92mm  
package body

**G Package**  
Top View

### BLOCK DIAGRAM

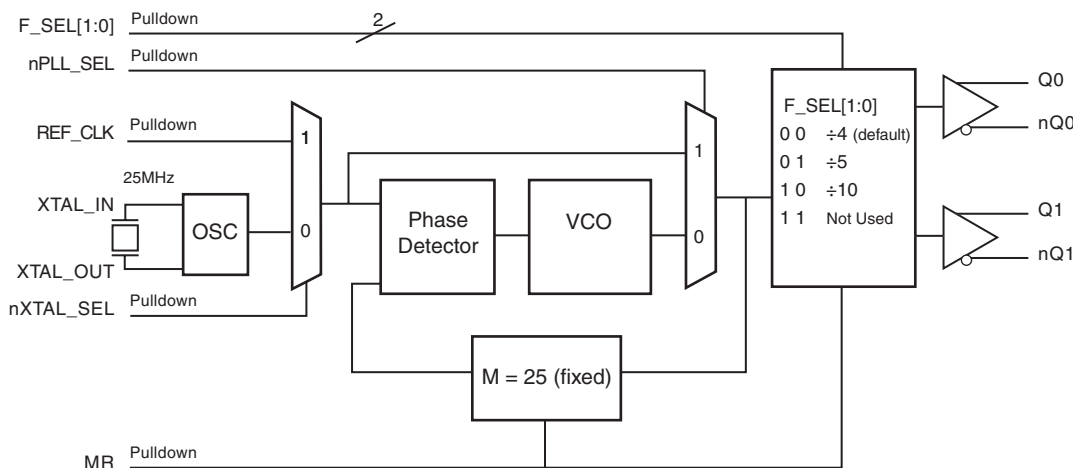



**TABLE 1. PIN DESCRIPTIONS**

Number	Name	Type		Description
1, 7	nc	Unused		No connect.
2, 20	V <sub>DDO</sub>	Power		Output supply pins.
3, 4	Q0, nQ0	Ouput		Differential output pair. HSTL interface levels.
5	MR	Input	Pulldown	Active HIGH Master Reset. When logic HIGH, the internal dividers are reset causing the true outputs Qx to go low and the inverted outputs nQx to go high. When logic LOW, the internal dividers and the outputs are enabled. LVCMOS/LVTTL interface levels.
6	nPLL_SEL	Input	Pulldown	Selects between the PLL and REF_CLK as input to the dividers. When LOW, selects PLL (PLL Enable). When HIGH, deselects the reference clock (PLL Bypass). LVCMOS/LVTTL interface levels.
8	V <sub>DDA</sub>	Power		Analog supply pin.
9, 11	F_SEL0, F_SEL1	Input	Pulldown	Frequency select pins. LVCMOS/LVTTL interface levels.
10, 16	V <sub>DD</sub>	Power		Core supply pin.
12, 13	XTAL_OUT, XTAL_IN	Input		Parallel resonant crystal interface. XTAL_OUT is the output, XTAL_IN is the input.
14	REF_CLK	Input	Pulldown	LVCMOS/LVTTL reference clock input.
15	nXTAL_SEL	Input	Pulldown	Selects between crystal or REF_CLK inputs as the the PLL Reference source. Selects XTAL inputs when LOW. Selects REF_CLK when HIGH. LVCMOS/LVTTL interface levels.
17	GND	Power		Power supply ground.
18, 19	nQ1, Q1	Output		Differential output pair. HSTL interface levels.

NOTE: *Pulldown* refers to internal input resistors. See Table 2, Pin Characteristics, for typical values.

**TABLE 2. PIN CHARACTERISTICS**

Symbol	Parameter	Test Conditions	Minimum	Typical	Maximum	Units
C <sub>IN</sub>	Input Capacitance			4		pF
R <sub>PULLDOWN</sub>	Input Pulldown Resistor			51		kΩ



**ABSOLUTE MAXIMUM RATINGS**

Supply Voltage, $V_{DD}$	4.6V
Inputs, $V_I$	-0.5V to $V_{DD} + 0.5V$
Outputs, $I_O$	
Continuous Current	50mA
Surge Current	100mA
Package Thermal Impedance, $\theta_{JA}$	73.2°C/W (0 lfpm)
Storage Temperature, $T_{STG}$	-65°C to 150°C

NOTE: Stresses beyond those listed under Absolute Maximum Ratings may cause permanent damage to the device. These ratings are stress specifications only. Functional operation of product at these conditions or any conditions beyond those listed in the *DC Characteristics* or *AC Characteristics* is not implied. Exposure to absolute maximum rating conditions for extended periods may affect product reliability.

**TABLE 3A. POWER SUPPLY DC CHARACTERISTICS,  $V_{DD} = V_{DDA} = 3.3V \pm 5\%$ ,  $V_{DDO} = 1.8V \pm 0.2V$ ,  $T_A = -40^\circ C$  TO  $85^\circ C$**

Symbol	Parameter	Test Conditions	Minimum	Typical	Maximum	Units
$V_{DD}$	Core Supply Voltage		3.135	3.3	3.465	V
$V_{DDA}$	Analog Supply Voltage		3.135	3.3	3.465	V
$V_{DDO}$	Output Supply Voltage		3.135	3.3	3.465	V
$I_{DD}$	Power Supply Current				110	mA
$I_{DDA}$	Analog Supply Current				12	mA
$I_{DDO}$	Output Supply Current	No Load		0		mA

**TABLE 3B. POWER SUPPLY DC CHARACTERISTICS,  $V_{DD} = V_{DDA} = 2.5V \pm 5\%$ ,  $V_{DDO} = 1.8V \pm 0.2V$ ,  $T_A = -40^\circ C$  TO  $85^\circ C$**

Symbol	Parameter	Test Conditions	Minimum	Typical	Maximum	Units
$V_{DD}$	Core Supply Voltage		2.375	2.5	2.625	V
$V_{DDA}$	Analog Supply Voltage		2.375	2.5	2.625	V
$V_{DDO}$	Output Supply Voltage		2.375	2.5	2.625	V
$I_{DD}$	Power Supply Current				96	mA
$I_{DDA}$	Analog Supply Current				12	mA
$I_{DDO}$	Output Supply Current	No Load		0		mA

**TABLE 3C. LVCMOS / LVTTL DC CHARACTERISTICS,  $V_{DD} = V_{DDA} = 3.3V \pm 5\%$  OR  $2.5V \pm 5\%$ ,  $V_{DDO} = 1.8V \pm 0.2V$ ,  $T_A = -40^\circ C$  TO  $85^\circ C$**

Symbol	Parameter	Test Conditions	Minimum	Typical	Maximum	Units
$V_{IH}$	Input High Voltage	$V_{DD} = 3.3V$	2		$V_{DD} + 0.3$	V
		$V_{DD} = 2.5V$	1.7		$V_{DD} + 0.3$	V
$V_{IL}$	Input Low Voltage	$V_{DD} = 3.3V$	-0.3		0.8	V
		$V_{DD} = 2.5V$	-0.3		0.7	V
$I_{IH}$	Input High Current	REF_CLK, MR, F_SEL0, F_SEL1, nPLL_SEL, nXTAL_SEL $V_{DD} = V_{IN} = 3.465$ or 2.5V			150	$\mu A$
$I_{IL}$	Input Low Current	REF_CLK, MR, F_SEL0, F_SEL1, nPLL_SEL, nXTAL_SEL $V_{DD} = 3.465V$ or 2.5V, $V_{IN} = 0V$	-150			$\mu A$



**TABLE 3D. HSTL DC CHARACTERISTICS,  $V_{DD} = V_{DDA} = 3.3V \pm 5\%$ ,  $V_{DDO} = 1.8V \pm 0.2V$ ,  $T_A = -40^\circ\text{C}$  TO  $85^\circ\text{C}$**

Symbol	Parameter	Test Conditions	Minimum	Typical	Maximum	Units
$V_{OH}$	Output High Voltage; NOTE 1		1.0		1.5	V
$V_{OL}$	Output Low Voltage; NOTE 1		0		0.5	V
$V_{OX}$	Output Crossover Voltage; NOTE 2		40		60	%
$V_{SWING}$	Peak-to-Peak Output Voltage Swing		0.6		1.3	V

NOTE 1: Outputs terminated with  $50\Omega$  to ground.

NOTE 2: Defined with respect to output voltage swing at a given condition.

**TABLE 3E. HSTL DC CHARACTERISTICS,  $V_{DD} = V_{DDA} = 2.5V \pm 5\%$ ,  $V_{DDO} = 1.8V \pm 0.2V$ ,  $T_A = -40^\circ\text{C}$  TO  $85^\circ\text{C}$**

Symbol	Parameter	Test Conditions	Minimum	Typical	Maximum	Units
$V_{OH}$	Output High Voltage; NOTE 1		0.8		1.5	V
$V_{OL}$	Output Low Voltage; NOTE 1		0		0.6	V
$V_{OX}$	Output Crossover Voltage; NOTE 2		40		60	%
$V_{SWING}$	Peak-to-Peak Output Voltage Swing		0.5		1.5	V

NOTE 1: Outputs terminated with  $50\Omega$  to ground.

NOTE 2: Defined with respect to output voltage swing at a given condition.

**TABLE 4. CRYSTAL CHARACTERISTICS**

Parameter	Test Conditions	Minimum	Typical	Maximum	Units
Mode of Oscillation		Fundamental			
Frequency		22.4	25	27.2	MHz
Equivalent Series Resistance (ESR)				50	$\Omega$
Shunt Capacitance				7	pF
Drive Level				1	mW

NOTE: Characterized using an 18pF parallel resonant crystal.



**TABLE 5A. AC CHARACTERISTICS,  $V_{DD} = V_{DDA} = 3.3V \pm 5\%$ ,  $V_{DDO} = 1.8V \pm 0.2V$ ,  $T_A = -40^\circ C$  TO  $85^\circ C$**

Symbol	Parameter	Test Conditions	Minimum	Typical	Maximum	Units
$f_{OUT}$	Output Frequency	F_SEL[1:0] = 00	140		170	MHz
		F_SEL[1:0] = 01	112		136	MHz
		F_SEL[1:0] = 10	56		68	MHz
tsk(o)	Output Skew; NOTE 1, 3				20	ps
fjit( $\emptyset$ )	RMS Phase Jitter (Random); NOTE 2	156.25MHz, (1.875MHz - 20MHz)		0.44		ps
		125MHz, (1.875MHz - 20MHz)		0.48		ps
		62.5MHz, (1.875MHz - 20MHz)		0.49		ps
$t_R / t_F$	Output Rise/Fall Time	20% to 80%	215		815	ps
odc	Output Duty Cycle		48		52	%

NOTE 1: Defined as skew between outputs at the same supply voltages and with equal load conditions.  
Measured at  $V_{DDO}/2$ .

NOTE 2: Please refer to the Phase Noise Plot.

NOTE 3: This parameter is defined in accordance with JEDEC Standard 65.

**TABLE 5B. AC CHARACTERISTICS,  $V_{DD} = V_{DDA} = 2.5V \pm 5\%$ ,  $V_{DDO} = 1.8V \pm 0.2V$ ,  $T_A = -40^\circ C$  TO  $85^\circ C$**

Symbol	Parameter	Test Conditions	Minimum	Typical	Maximum	Units
$f_{OUT}$	Output Frequency	F_SEL[1:0] = 00	140		170	MHz
		F_SEL[1:0] = 01	112		136	MHz
		F_SEL[1:0] = 10	56		68	MHz
tsk(o)	Output Skew; NOTE 1, 3				20	ps
fjit( $\emptyset$ )	RMS Phase Jitter (Random); NOTE 2	156.25MHz, (1.875MHz - 20MHz)		0.41		ps
		125MHz, (1.875MHz - 20MHz)		0.49		ps
		62.5MHz, (1.875MHz - 20MHz)		0.50		ps
$t_R / t_F$	Output Rise/Fall Time	20% to 80%	315		715	ps
odc	Output Duty Cycle		48		52	%

NOTE 1: Defined as skew between outputs at the same supply voltages and with equal load conditions.  
Measured at  $V_{DDO}/2$ .

NOTE 2 Please refer to the Phase Noise Plot.

NOTE 3 This parameter is defined in accordance with JEDEC Standard 65.



### TYPICAL PHASE NOISE AT 156.25MHz @ 3.3V

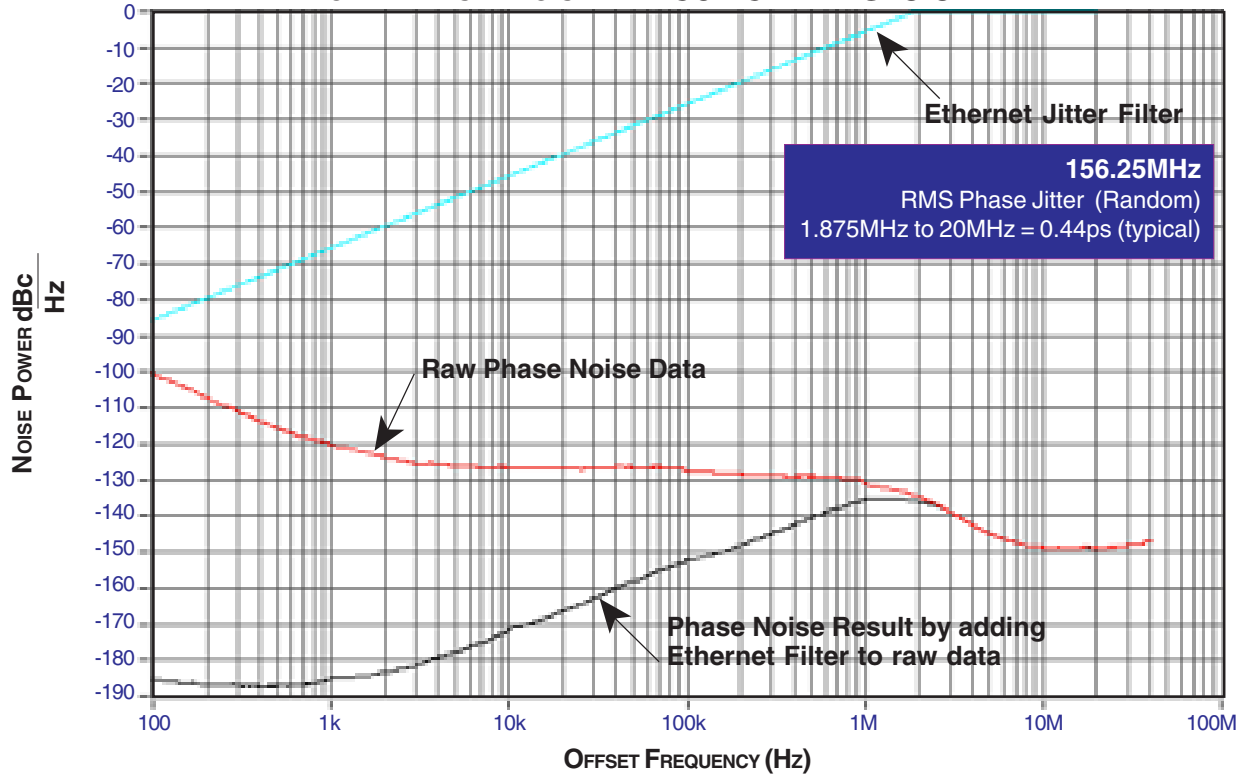

### TYPICAL PHASE NOISE AT 62.5MHz @ 3.3V

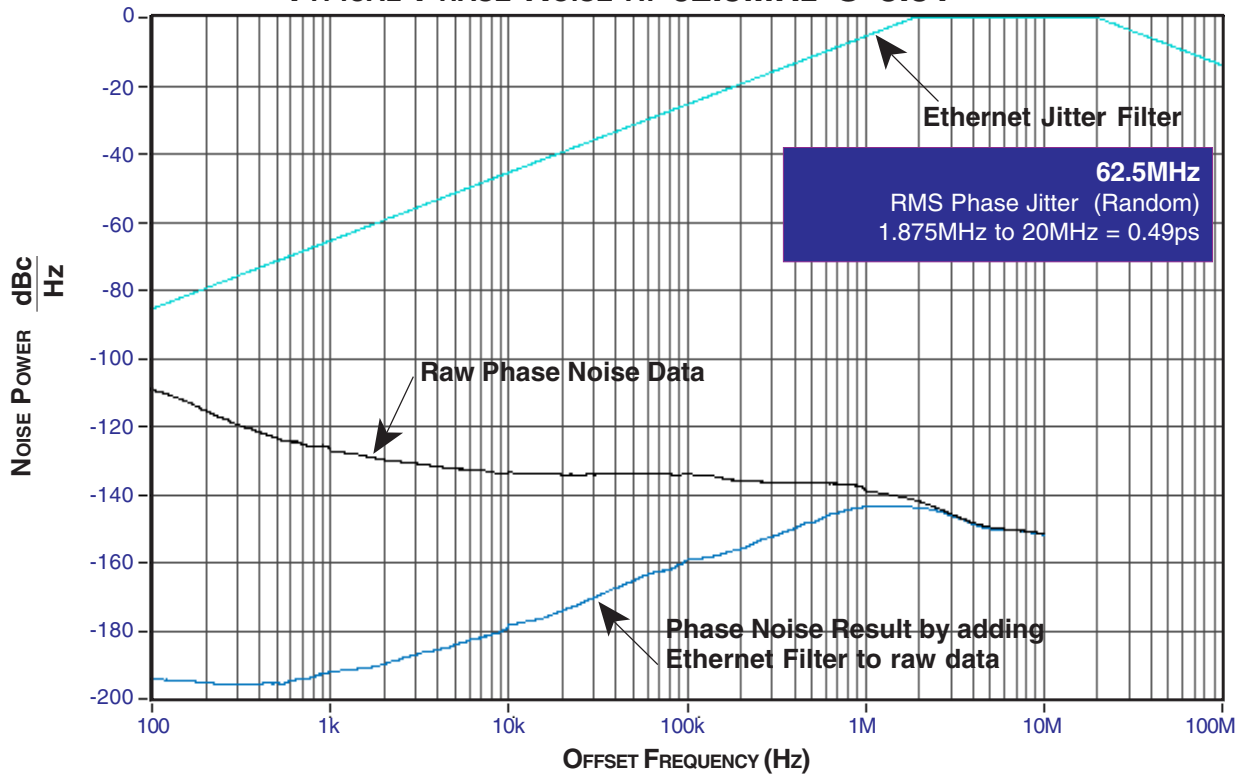



## PARAMETER MEASUREMENT INFORMATION

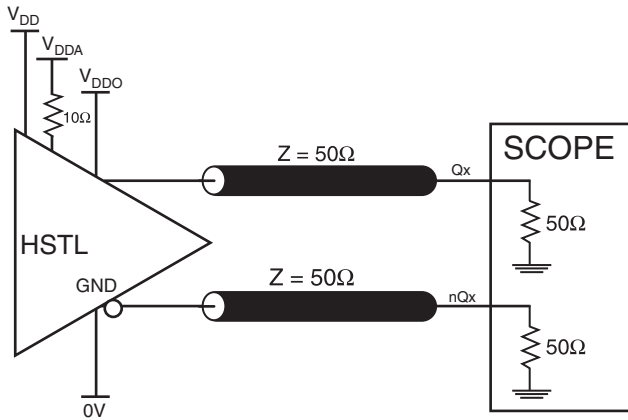

**HSTL 3.3V/1.8V OUTPUT LOAD AC TEST CIRCUIT**

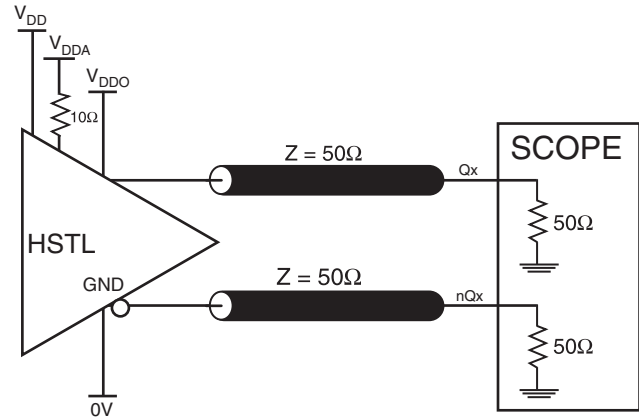

**HSTL 2.5V/1.8V OUTPUT LOAD AC TEST CIRCUIT**

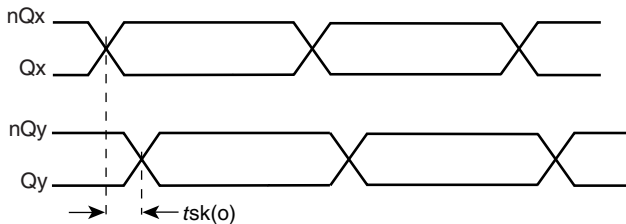

**OUTPUT SKEW**

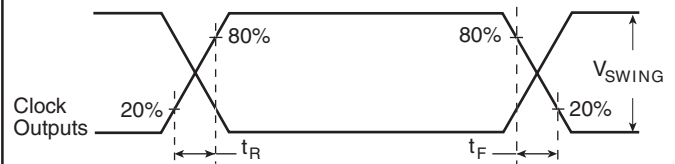

**OUTPUT RISE/FALL TIME**

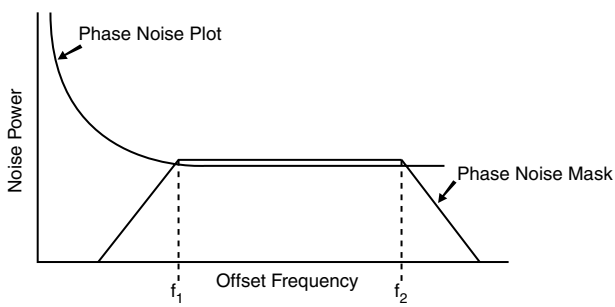

$$\text{RMS Jitter} = \sqrt{\text{Area Under the Masked Phase Noise Plot}}$$

**RMS PHASE JITTER**

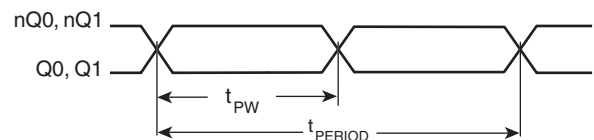

$$\text{odc} = \frac{t_{PW}}{t_{PERIOD}} \times 100\%$$

**OUTPUT DUTY CYCLE/PULSE WIDTH/PERIOD**



## APPLICATION INFORMATION

### POWER SUPPLY FILTERING TECHNIQUES

As in any high speed analog circuitry, the power supply pins are vulnerable to random noise. The ICS8421002I-01 provides separate power supplies to isolate any high switching noise from the outputs to the internal PLL.  $V_{DD}$ ,  $V_{DDA}$ , and  $V_{DDO}$  should be individually connected to the power supply plane through vias, and bypass capacitors should be used for each pin. To achieve optimum jitter performance, power supply isolation is required. *Figure 1* illustrates how a  $10\Omega$  resistor along with a  $10\mu\text{F}$  and a  $.01\mu\text{F}$  bypass capacitor should be connected to each  $V_{DDA}$ .

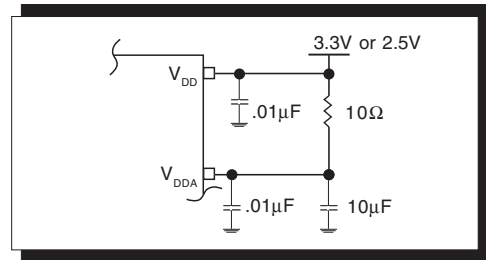

FIGURE 1. POWER SUPPLY FILTERING

### CRYSTAL INPUT INTERFACE

The ICS8421002I-01 has been characterized with 18pF parallel resonant crystals. The capacitor values shown in *Figure*

2 below were determined using a 25MHz 18pF parallel resonant crystal and were chosen to minimize the ppm error.

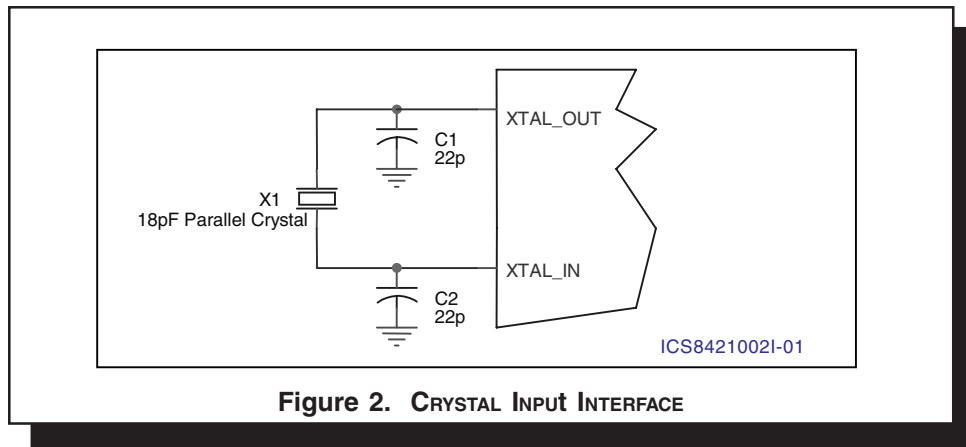

Figure 2. CRYSTAL INPUT INTERFACE





## POWER CONSIDERATIONS

This section provides information on power dissipation and junction temperature for the ICS8421002I-01. Equations and example calculations are also provided.

### 1. Power Dissipation.

The total power dissipation for the ICS8421002I-01 is the sum of the core power plus the power dissipated in the load(s). The following is the power dissipation for  $V_{DD} = 3.3V + 5\% = 3.465V$ , which gives worst case results.

**NOTE:** Please refer to Section 3 for details on calculating power dissipated in the load.

- Power (core)<sub>MAX</sub> =  $V_{DD\_MAX} * I_{DD\_MAX} = 3.465V * 122mA = 422.7mW$
- Power (outputs)<sub>MAX</sub> = **32.8mW/Loaded Output pair**  
If all outputs are loaded, the total power is  $2 * 32.8mW = 65.6mW$

$$\text{Total Power}_{MAX} (3.465V, \text{ with all outputs switching}) = 422.7mW + 65.6mW = 488.3mW$$

### 2. Junction Temperature.

Junction temperature,  $T_j$ , is the temperature at the junction of the bond wire and bond pad and directly affects the reliability of the device. The maximum recommended junction temperature for HiPerClockS™ devices is 125°C.

The equation for  $T_j$  is as follows:  $T_j = \theta_{JA} * Pd\_total + T_A$

$T_j$  = Junction Temperature

$\theta_{JA}$  = Junction-to-Ambient Thermal Resistance

$Pd\_total$  = Total Device Power Dissipation (example calculation is in section 1 above)

$T_A$  = Ambient Temperature

In order to calculate junction temperature, the appropriate junction-to-ambient thermal resistance  $\theta_{JA}$  must be used. Assuming a moderate air flow of 200 linear feet per minute and a multi-layer board, the appropriate value is 66.6°C/W per Table 6 below.

Therefore,  $T_j$  for an ambient temperature of 85°C with all outputs switching is:

$$85^\circ C + 0.488W * 66.6^\circ C/W = 117.5^\circ C. \text{ This is below the limit of } 125^\circ C.$$

This calculation is only an example.  $T_j$  will obviously vary depending on the number of loaded outputs, supply voltage, air flow, and the type of board (single layer or multi-layer).

**TABLE 6. THERMAL RESISTANCE  $\theta_{JA}$  FOR 20-PIN TSSOP, FORCED CONVECTION**

$\theta_{JA}$ by Velocity (Linear Feet per Minute)			
	0	200	500
Single-Layer PCB, JEDEC Standard Test Boards	114.5°C/W	98.0°C/W	88.0°C/W
Multi-Layer PCB, JEDEC Standard Test Boards	73.2°C/W	66.6°C/W	63.5°C/W

**NOTE:** Most modern PCB designs use multi-layered boards. The data in the second row pertains to most designs.



### 3. Calculations and Equations.

The purpose of this section is to derive the power dissipated into the load.

HSTL output driver circuit and termination are shown in *Figure 3*.

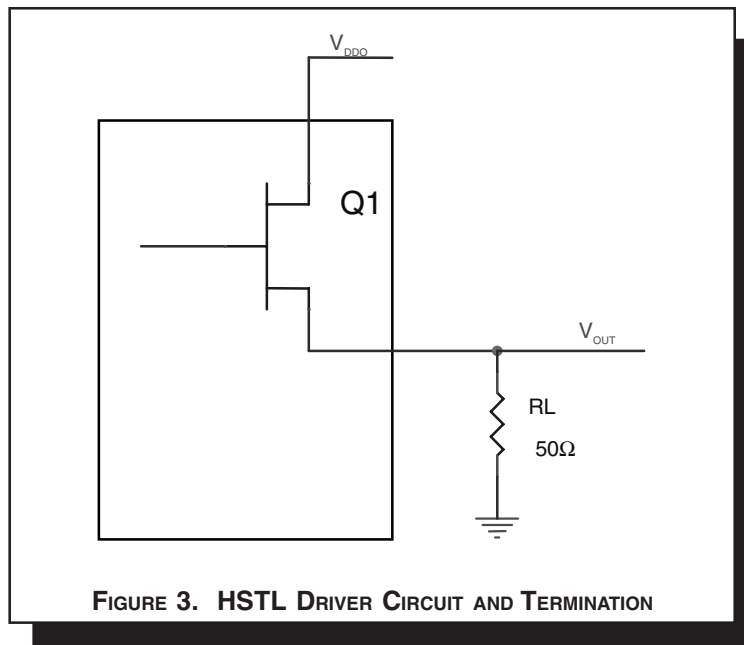

To calculate worst case power dissipation into the load, use the following equations which assume a 50Ω load.

Pd\_H is power dissipation when the output drives high.

Pd\_L is the power dissipation when the output drives low.

$$Pd_H = (V_{OH\_MAX} / R_L) * (V_{DD\_MAX} - V_{OH\_MAX})$$

$$Pd_L = (V_{OL\_MAX} / R_L) * (V_{DD\_MAX} - V_{OL\_MAX})$$

$$Pd_H = (1V/50\Omega) * (2V - 1V) = \mathbf{20mW}$$

$$Pd_L = (0.4V/50\Omega) * (2V - 0.4V) = \mathbf{12.8mW}$$

$$\text{Total Power Dissipation per output pair} = Pd_H + Pd_L = \mathbf{32.8mW}$$



## RELIABILITY INFORMATION

TABLE 7.  $\theta_{JA}$  vs. AIR FLOW TABLE FOR 20 LEAD TSSOP

$\theta_{JA}$ by Velocity (Linear Feet per Minute)			
	0	200	500
Single-Layer PCB, JEDEC Standard Test Boards	114.5°C/W	98.0°C/W	88.0°C/W
Multi-Layer PCB, JEDEC Standard Test Boards	73.2°C/W	66.6°C/W	63.5°C/W

**NOTE:** Most modern PCB designs use multi-layered boards. The data in the second row pertains to most designs.

### TRANSISTOR COUNT

The transistor count for ICS8421002I-01 is: 2951



PACKAGE OUTLINE - G SUFFIX FOR 20 LEAD TSSOP

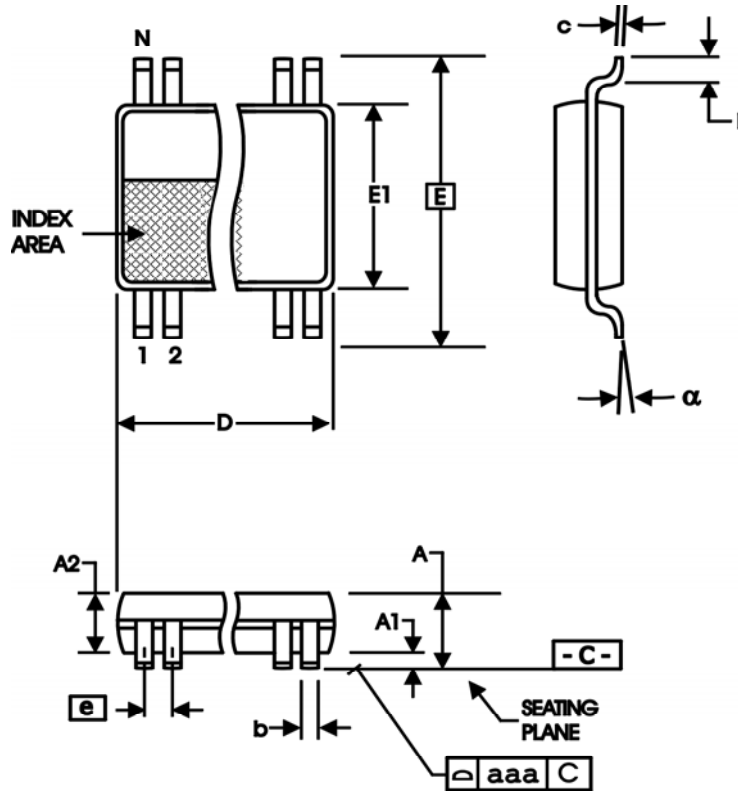

TABLE 7. PACKAGE DIMENSIONS

SYMBOL	Millimeters	
	MIN	MAX
N	20	
A	--	1.20
A1	0.05	0.15
A2	0.80	1.05
b	0.19	0.30
c	0.09	0.20
D	6.40	6.60
E	6.40 BASIC	
E1	4.30	4.50
e	0.65 BASIC	
L	0.45	0.75
α	0°	8°
aaa	--	0.10

Reference Document: JEDEC Publication 95, MO-153



Integrated  
Circuit  
Systems, Inc.

# ICS8421002I-01

## FEMTOCLOCKS™ CRYSTAL-TO- HSTL FREQUENCY SYNTHESIZER

**TABLE 9. ORDERING INFORMATION**

Part/Order Number	Marking	Package	Shipping Packaging	Temperature
ICS8421002AGI-01	ICS421002AI01	20 Lead TSSOP	tube	-40°C to 85°C
ICS8421002AGI-01T	ICS421002AI01	20 Lead TSSOP	2500 tape & reel	-40°C to 85°C
ICS8421002AGI-01LF	ICS1002AI01L	20 Lead "Lead-Free" TSSOP	tube	-40°C to 85°C
ICS8421002AGI-01LFT	ICS1002AI01L	20 Lead "Lead-Free" TSSOP	2500 tape & reel	-40°C to 85°C

NOTE: Parts that are ordered with an "LF" suffix to the part number are the Pb-Free Configuration and are RoHS compliant.

The aforementioned trademarks, HiPerClockS and FemtoClocks are trademarks of Integrated Circuit Systems, Inc. or its subsidiaries in the United States and/or other countries. While the information presented herein has been checked for both accuracy and reliability, Integrated Circuit Systems, Incorporated (ICS) assumes no responsibility for either its use or for infringement of any patents or other rights of third parties, which would result from its use. No other circuits, patents, or licenses are implied. This product is intended for use in normal commercial and industrial applications. Any other applications such as those requiring high reliability or other extraordinary environmental requirements are not recommended without additional processing by ICS. ICS reserves the right to change any circuitry or specifications without notice. ICS does not authorize or warrant any ICS product for use in life support devices or critical medical instruments.