



# RF Power Field Effect Transistor LDMOS, 800—1700 MHz, 15W, 26V

1/11/06

Preliminary

MAPL-000817-015C00



## Features

- Designed for broadband commercial applications up to 1.7GHz
- High Gain, High Efficiency and High Linearity
- Typical P1dB performance at 960MHz, 26Vdc, CW
  - Typical Power Output: 16.5W
  - Gain: 16.5dB
  - Efficiency: 50%
  - 10:1 VSWR Ruggedness at 15W, 26Vdc, 960MHz

## Package Style

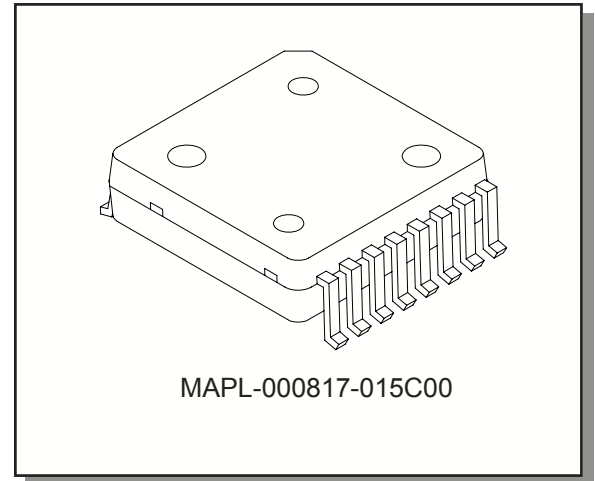

## Maximum Ratings

Parameter	Symbol	Rating	Units
Drain—Source Voltage	$V_{DSS}$	65	V <sub>dc</sub>
Gate—Source Voltage	$V_{GS}$	+20, -20	V <sub>dc</sub>
Total Power Dissipation @ T <sub>c</sub> = 25 °C	P <sub>d</sub>	31.25	W
Storage Temperature	T <sub>STG</sub>	-65 to +150	°C
Junction Temperature	T <sub>J</sub>	150	°C

## Thermal Characteristics

Characteristic	Symbol	Max	Unit
Thermal Resistance, Junction to Case	R <sub>θJC</sub>	4	°C/W

NOTE—**CAUTION**—MOS devices are susceptible to damage from electrostatic charge. Precautions in handling and packaging MOS devices should be observed.

Characteristic	Symbol	Min	Typ	Max	Unit
<b>DC CHARACTERISTICS @ 25°C</b>					
Drain-Source Breakdown Voltage ( $V_{GS} = 0$ Vdc, $I_D = 30$ $\mu$ Adc)	$V_{(BR)DSS}$	65	—	—	Vdc
Gate Threshold Voltage ( $V_{ds} = 26$ Vdc, $I_d = 100$ mA)	$V_{GS(th)}$	2	—	5	Vdc
Gate Quiescent Voltage ( $V_{ds} = 26$ Vdc, $I_d = 100$ mA)	$V_{DS(Q)}$	3	—	5	Vdc
Drain-Source On-Voltage ( $V_{gs} = 10$ Vdc, $I_d = 1$ A)	$V_{DS(on)}$	—	0.25	—	Vdc
<b>RF FUNCTIONAL TESTS @ 25°C (In M/A-COM Test Fixture) (1)</b>					
Common Source Amplifier Gain ( $V_{DD} = 26$ Vdc, $I_{DQ} = 100$ mA, $f = 960$ MHz, $P_{OUT} = 15$ W)	$G_P$	—	17	—	dB
Drain Efficiency ( $V_{DD} = 26$ Vdc, $I_{DQ} = 100$ mA, $f = 960$ MHz, $P_{OUT} = 15$ W)	EFF ( $\eta$ )	—	50	—	%
Input Return Loss ( $V_{DD} = 26$ Vdc, $I_{DQ} = 100$ mA, $f = 960$ MHz, $P_{OUT} = 15$ W)	IRL	—	-10	—	dB
Output VSWR Tolerance ( $V_{DD} = 26$ Vdc, $I_{DQ} = 100$ mA, $f = 960$ MHz, $P_{OUT} = 15$ W, VSWR = 10:1, All Phase Angles at Frequency of Tests)	$\Psi$	No Degradation In Output Power Before and After Test			
Common Source Amplifier Gain ( $V_{DD} = 26$ Vdc, $I_{DQ} = 100$ mA, $f = 1670$ MHz, $P_{OUT} = 15$ W)	$G_P$	—	12.5	—	dB
Drain Efficiency ( $V_{DD} = 26$ Vdc, $I_{DQ} = 100$ mA, $f = 1670$ MHz, $P_{OUT} = 15$ W)	EFF ( $\eta$ )	—	50	—	%
Input Return Loss ( $V_{DD} = 26$ Vdc, $I_{DQ} = 100$ mA, $f = 1670$ MHz, $P_{OUT} = 15$ W)	IRL	—	-10	—	dB

(1) Device specifications obtained on a Production Test Fixture.

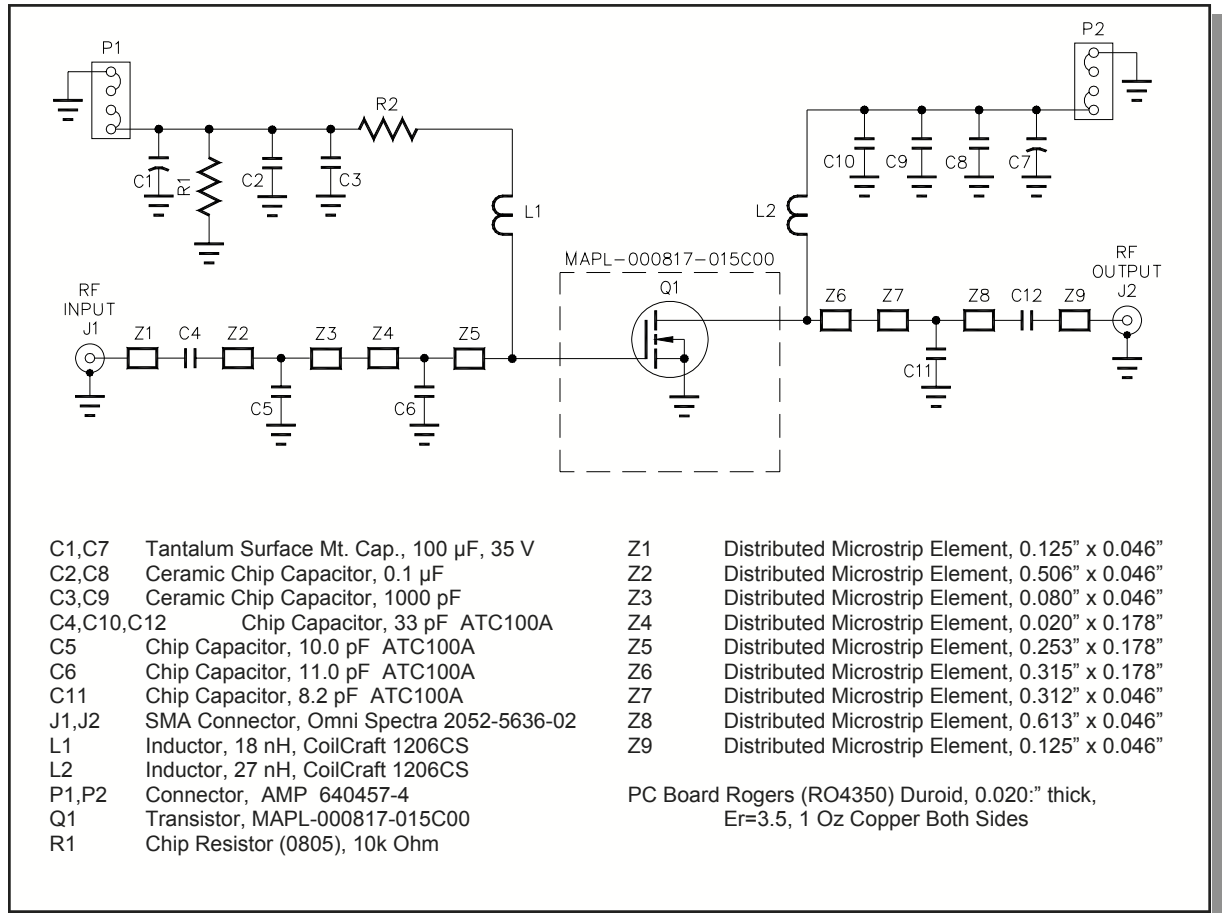

Figure 1. 920—960 MHz Test Fixture Schematic

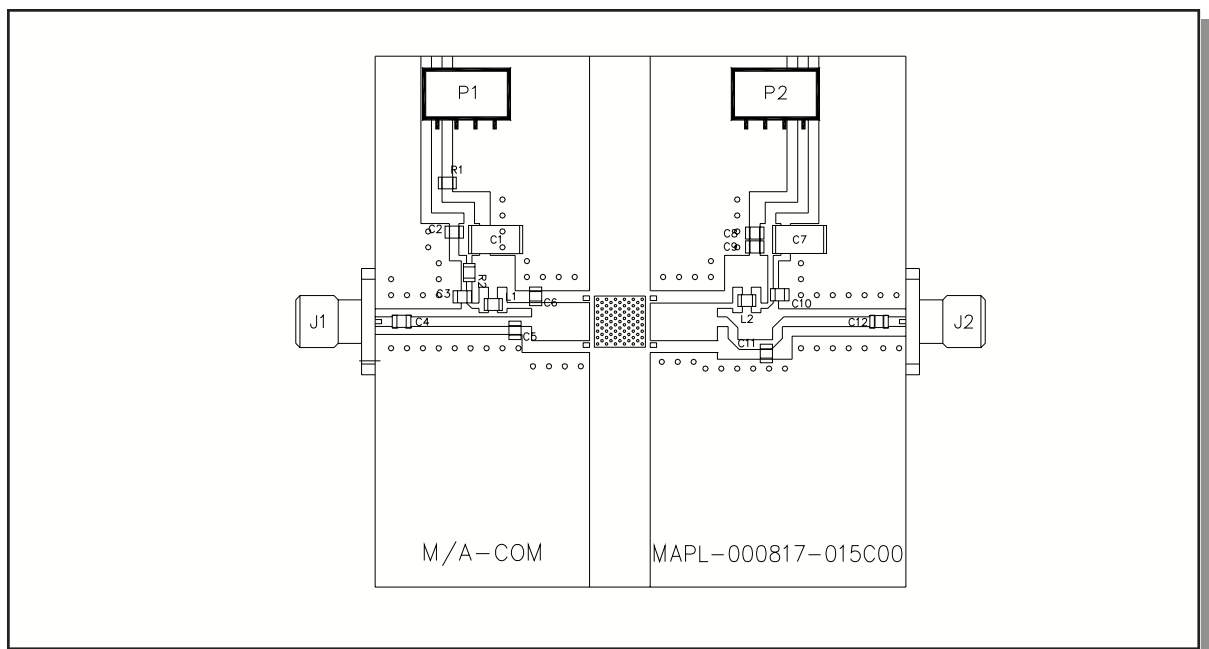

Figure 2. 920—960 MHz Test Fixture Component Layout

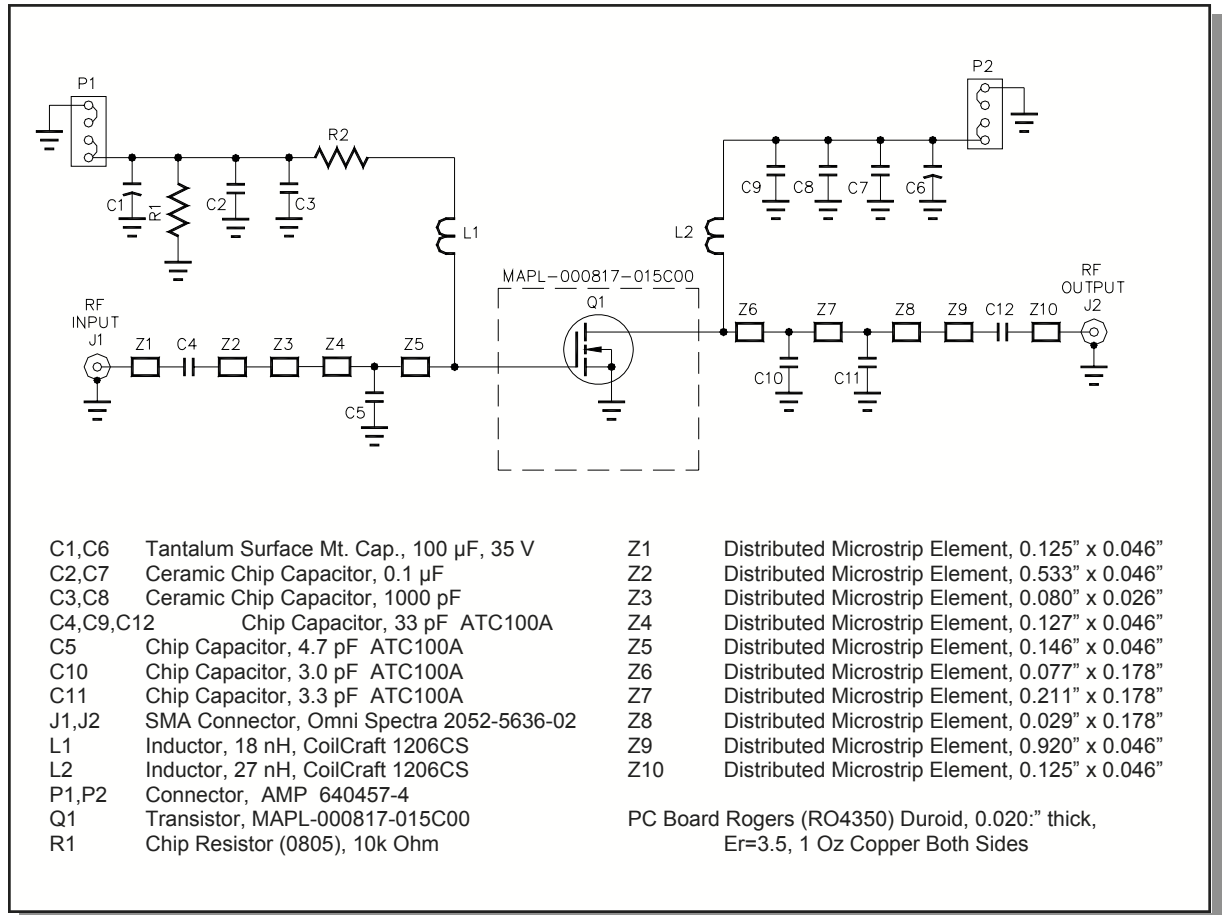

Figure 3. 1620-1670 MHz Test Fixture Schematic

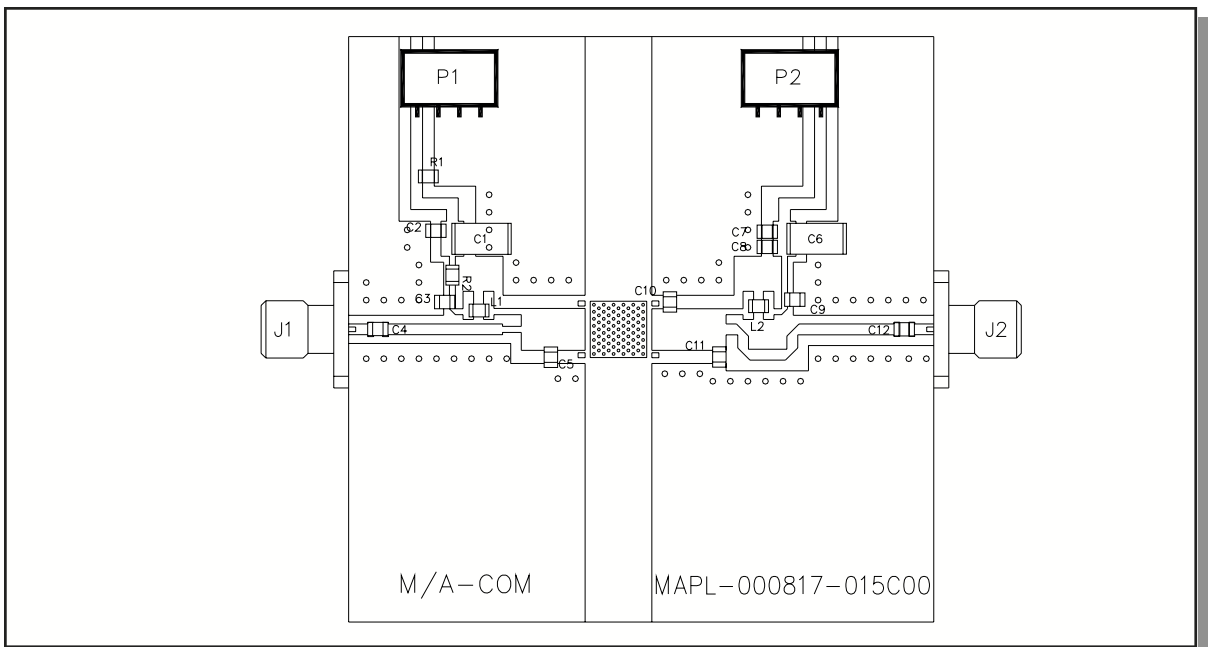
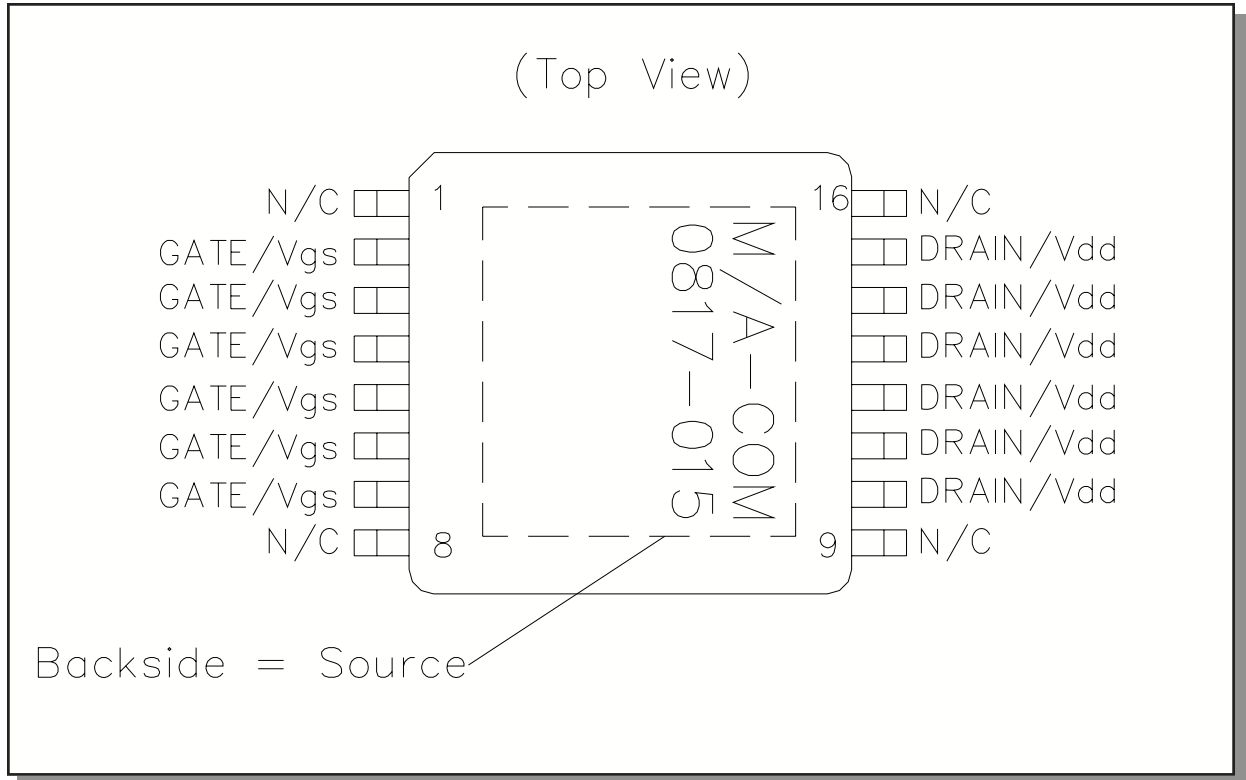
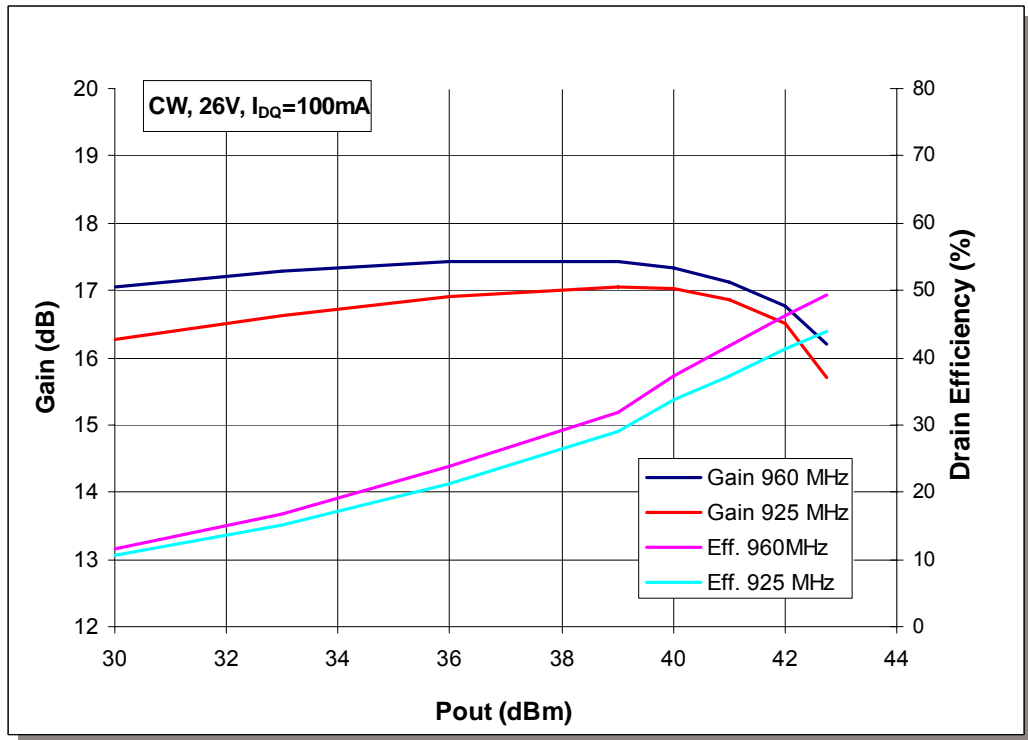

Figure 4. 1620—1670 MHz Test Fixture Component Layout

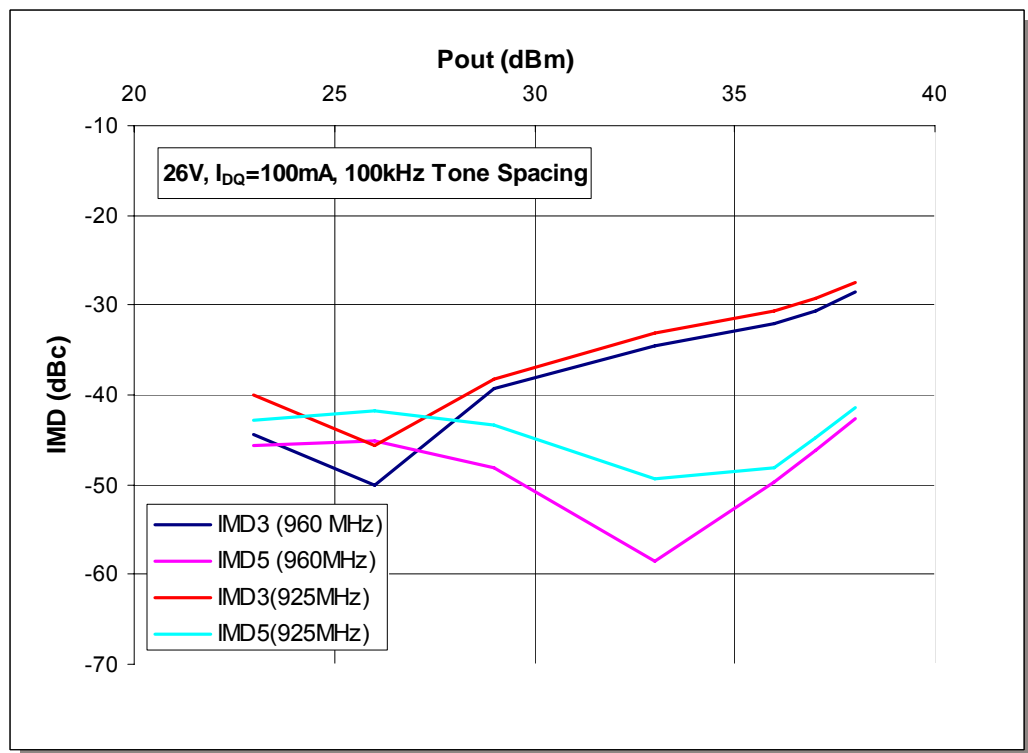

**Figure 5. MAPL-000817-015C00 Pin Connections**

Preliminary



Graph 1. 925, 960MHz: CW Power Gain and Drain Efficiency vs. Output Power



Graph 2. 925, 960 MHz: 2 Tone Intermodulation Distortion vs. Output Power

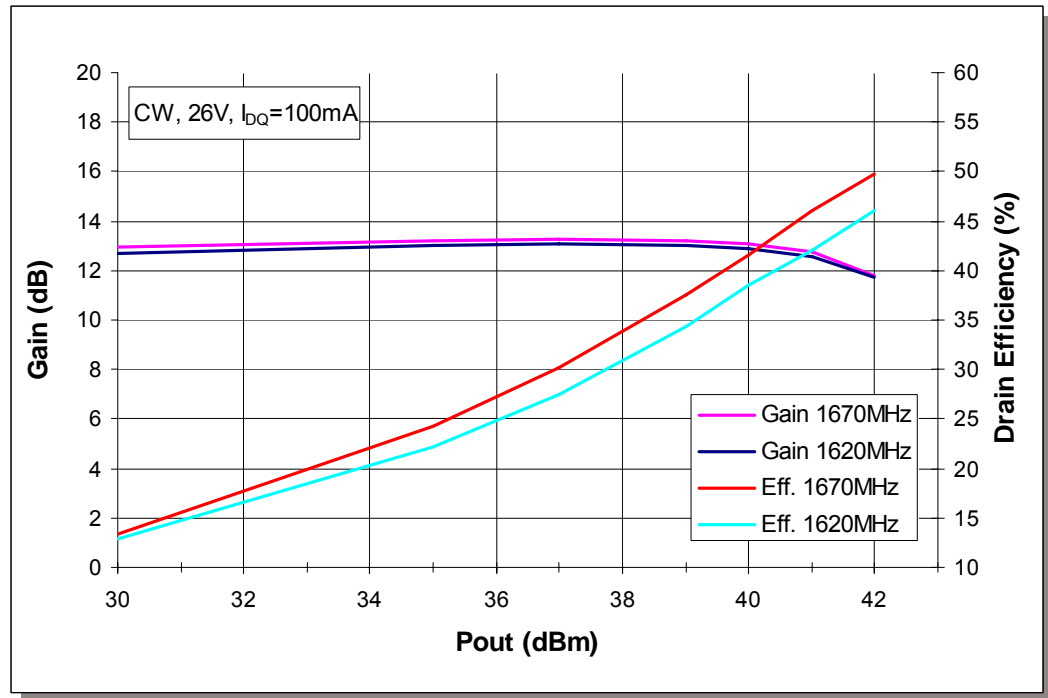

Graph 3. 1620, 1670MHz: CW Power Gain and Drain Efficiency vs. Output Power

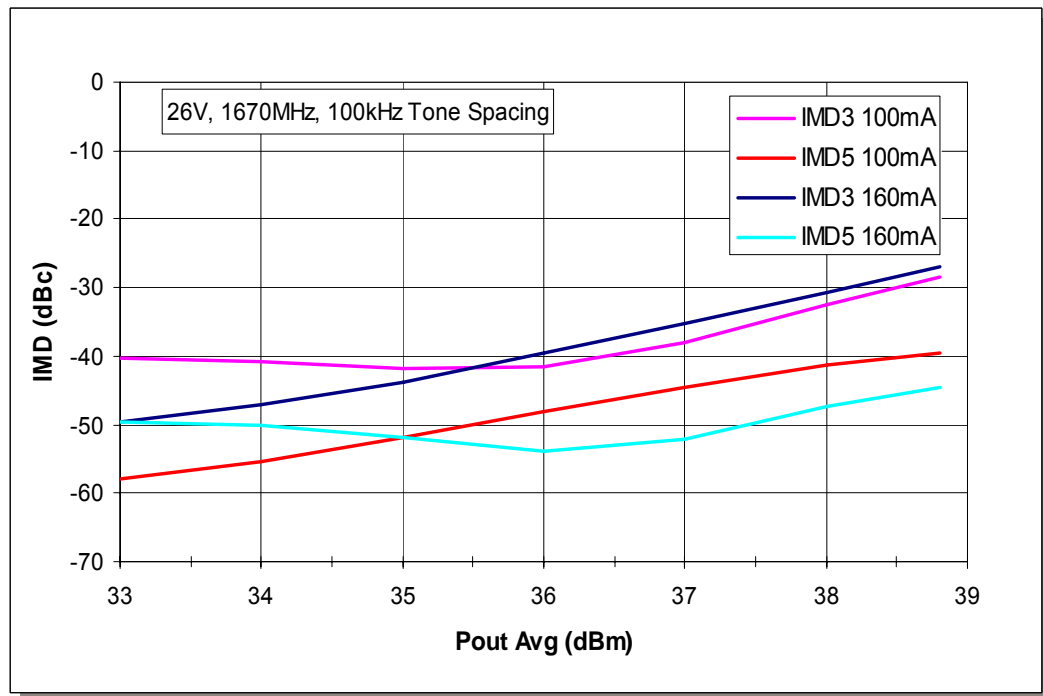

Graph 4. 1620, 1670MHz: 2 Tone Intermodulation Distortion vs. Output Power

Package Dimensions

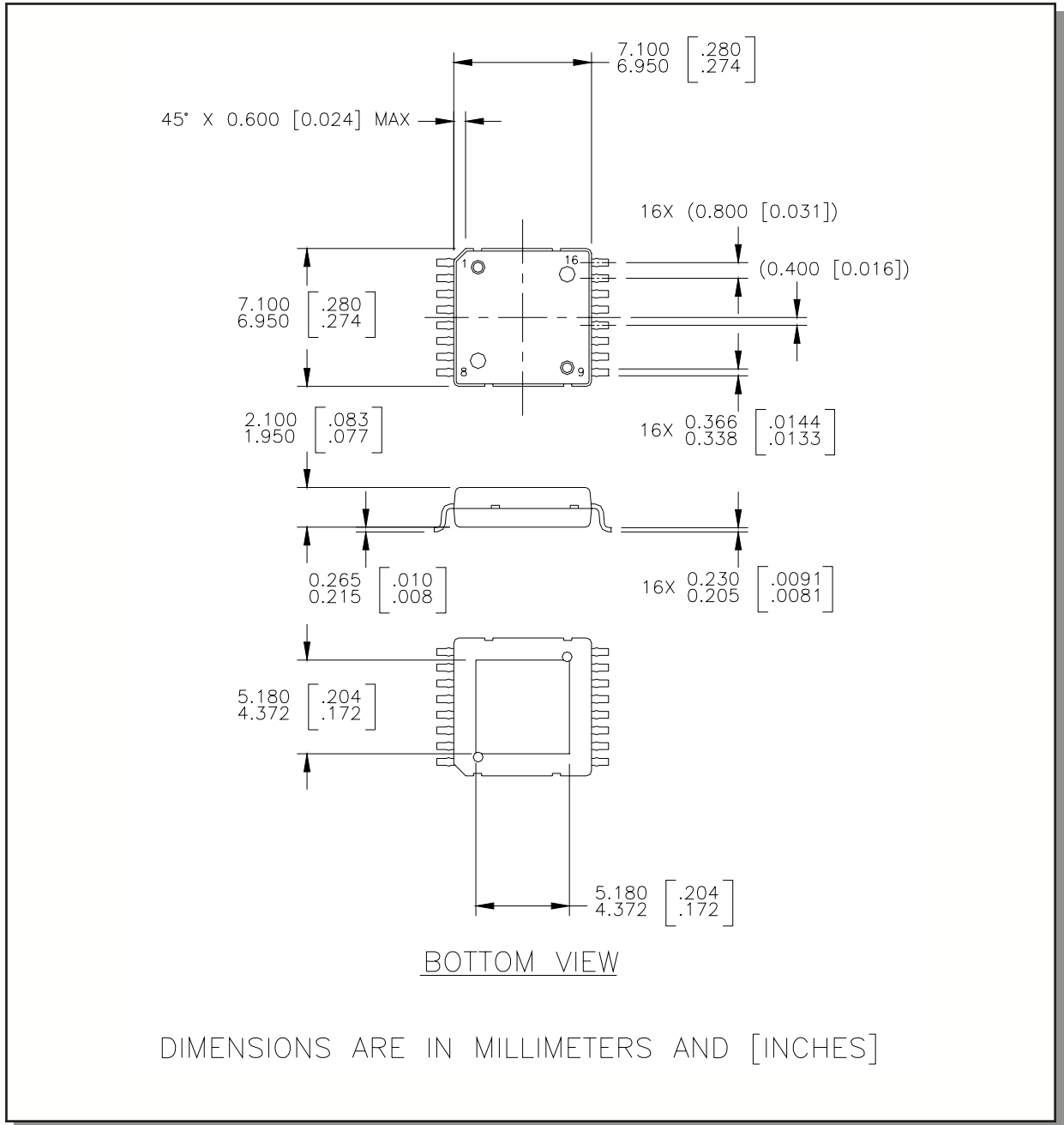

M/A-COM Inc. and its affiliates reserve the right to make changes to the product(s) or information contained herein without notice. M/A-COM makes no warranty, representation or guarantee regarding the suitability of its products for any particular purpose, nor does M/A-COM assume any liability whatsoever arising out of the use or application of any product(s) or information.

Visit [www.macom.com](http://www.macom.com) for additional data sheets and product information.

- North America: Tel. (800) 366-2266
- Asia/Pacific: Tel. +81-44-844-8296, Fax +81-44-844-8298
- Europe: Tel. +44 (1344) 869 595, Fax+44 (1344) 300 020