

2²⁴ OTP ENCODER

DESCRIPTION

The SC9314 is CMOS LSI encoder designed for remote control system applications. It encodes 24 bits of information and then serially transmits it via the DOUT pin upon receipt of transmission enable (DATA pins: D0~D3) signals. The combination of address and bits of the SC9314 is designed by a one-time programmable process. The chip, in addition, offers various packaging for flexible combination of programmable address/data so as to meet various applications. Its programmable address/data is transmitted together with the anti-code bits via RF or infrared transmission medium upon receipt of a trigger signal.

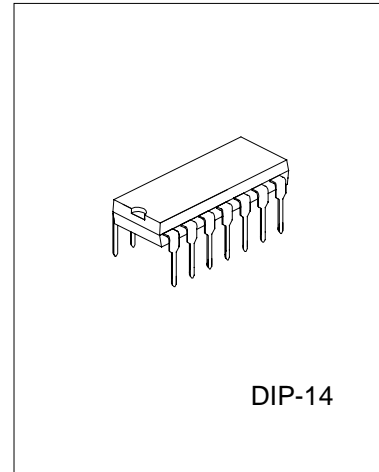

FEATURES

- * Operating voltage: 2V~12V
- * Low power consumption
- * Built-in oscillator needs only 5% resistor
- * 0/2/4/8 data selectable
- * 2²⁴ maximum address and data codes
- * Easy interface with RF or IR medium
- * One-time programmable
- * Data active: D0~D3
- * Minimal external components

APPLICATIONS

- * Burglar alarm system
- * Smoke and fire alarm system
- * Garage door controllers
- * Car door controllers
- * Security system
- * Cordless telephones
- * Other remote control systems

PIN CONFIGURATION

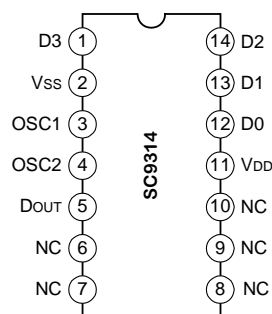

BLOCK DIAGRAM

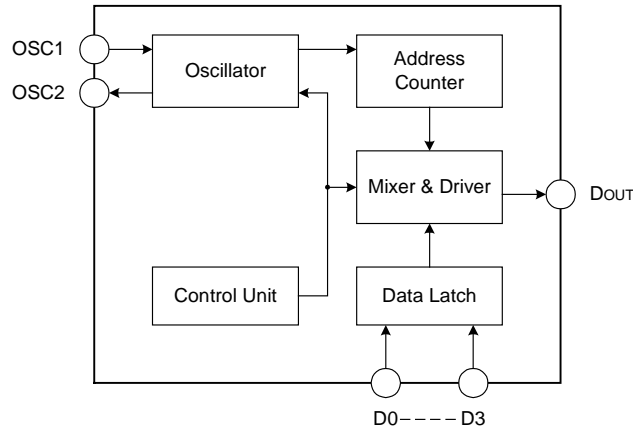

Note: Address/Data number are available in various combinations, refer to functional description.

ABSOLUTE MAXIMUM RATING

Characteristic	Symbol	Value	Unit
Supply Voltage	V _{DD}	0.3~12	V
Input Voltage	V _{IN}	0.3~ V _{DD} +0.3	V
Storage temperature	T _{STG}	-50 ~ 125	°C
Operating Temperature	T _{OPR}	-20 ~ 70	°C

ELECTRICAL CHARACTERISTICS (V_{DD} =5.0V, T_A=25°C)

Parameter	Symbol	Test conditions		Min	Typ	Max	Unit	
		V _{DD}	Condition					
Operating Voltage	V _{DD}			2		12	V	
Standby Current	I _{STB}	12V	Oscillator stops		1	2	A	
Operating Current	I _{DD}	12V	No load F _{OSC} =3KHz		200	400	A	
H Input Voltage	V _{IH}			0.8 V _{DD}		V _{DD}	V	
L Input Voltage	V _{IL}			0		0.2V _{DD}	V	
D0~D7 Pull-High Resistance	R _{PH}	12V			150	300	k	
Output Current	Source	I _{DOUT}	5V	0.9V _{DD}	2	5		mA
			12V	0.9V _{DD}	6.5	15		mA
	Sink		5V	0.1V _{DD}	2	5		mA
			12V	0.1V _{DD}	6	15		mA
Oscillator Frequency	F _{OSC}	12V	f _{OSC} =1.4M		3		kHz	

— HANGZHOU SILAN MICROELECTRONICS JOINT-STOCK CO.,LTD —

Rev: 1.0 2001.04.15

PIN DESCRIPTION

Pin No.	Symbol	I/O	Internal Connection	Description
14 1~3	D0~D3	I	CMOS IN Pull-High	Data input and transmission enable (active low). They can be externally set to VSS or left open.
4	Vss	I		Negative power supply (GND)
9	OSC2	O	OSCILLATOR	Oscillator output pin
10	OSC1	I	OSCILLATOR	Oscillator output pin
11	DOUT	O	CMOS OUT	Data serial transmission output
12	VDD	I		Positive power supply

APPROXIMATE INTERNAL CONNECTION CIRCUIT

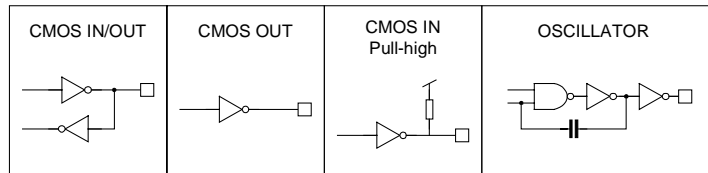

FUNCTIONAL DESCRIPTION

Normal operation

The SC9314 encodes and transmits address/data to a decoder upon receipt of a trigger signal. The address codes of SC9314 are always being transmitted as long as power (VDD) is supplied. The transmission function of the SC9314 is enabled by the D0~D3 pins (active low). The following is the transmission of the SC9314.

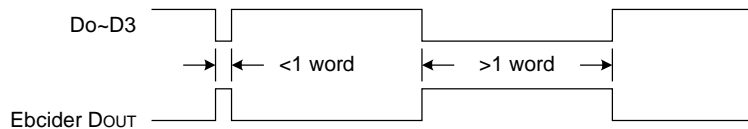

Transmission timing

A complete code word of the SC9314 consists of 3 periods as shown below.

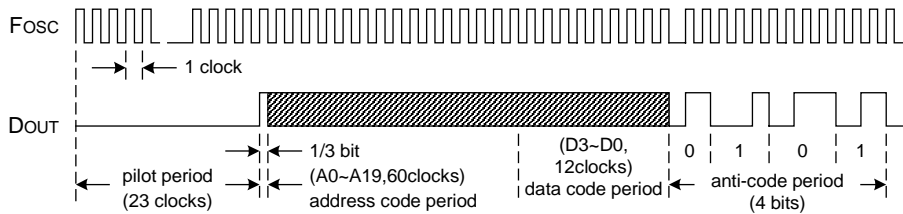

A complete code word for the SC9314

The SC9314 detects the logic state of the internal programmed address and the external data pins, and then transmits the detected information during the code period. Each address/data bit can be set to one of the following two logic states:

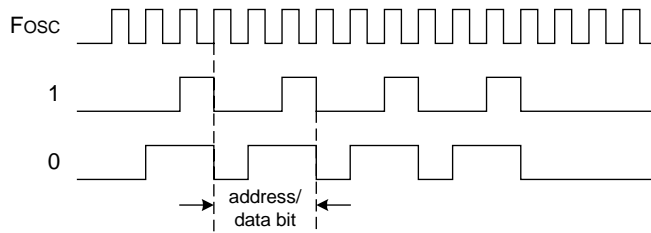

Flowchart

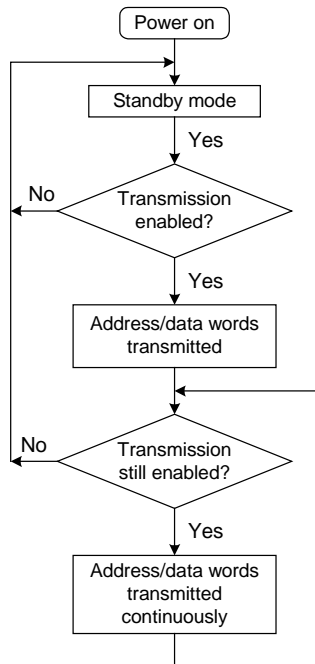

TYPICAL APPLICATION CIRCUITS

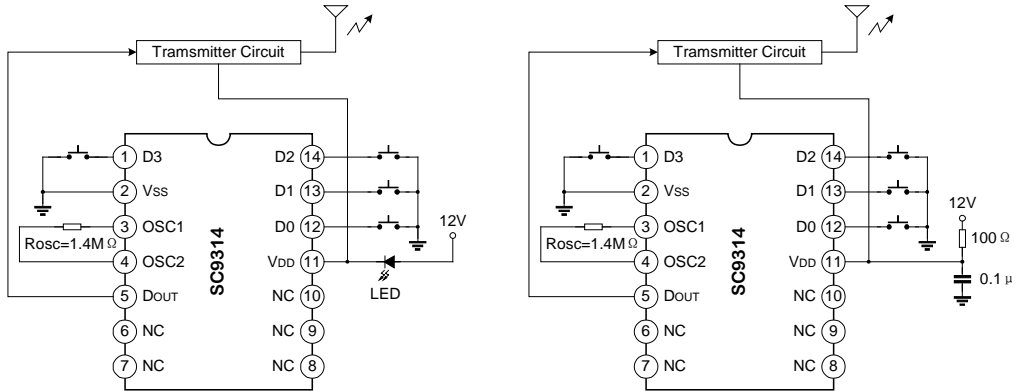

Note: In order to prevent the IC from being damaged owing to the latch up, the 100Ω resistor or the LED which also can be a transmission indicator is indispensable when VDD=9V-12V.

PACKAGE OUTLINE

