

## Feature

- Operating Voltage: 2.5V to 6.0V.
- High Operating Frequency: 1MHz
- High Output Voltage: Up to 16V/23V/28V
- Shutdown Current <math><1\mu\text{A}</math>
- 16V/23V/28V Output Over-Voltage Protection
- Digital Dimming Control.
- Built-in Cycle-by-Cycle Current-Limiting.
- Built-in Soft-Start Function.
- 0.2V Low Reference Voltage
- Tiny SOT-26 Package

## Application

- LED Module
- Compact Back Light Module
- Constant Current Source

## Description

The AT1312A/B/C step-up converter drives white LEDs with a constant current to provide backlight in cell phones, PDAs, and other hand-held devices. It features allowing series connection of the white LEDs so that the LED currents are identical for uniform brightness. An enable input can be pulsed repeatedly to adjust LED's brightness. The fast 1.0 MHz current-mode PWM control allows for smaller capacitor and inductor. Fault condition protection uses cycle-by-cycle current limiting to sense maximum inductor current, thermal protection and over-voltage protection. Also included soft-start eliminates inrush current during start-up. The 0.2V low reference voltage minimized the power loss across the current-setting resistor.

The AT1312A/B/C is available in 6-pin SOT-26 packages.

## Block Diagram

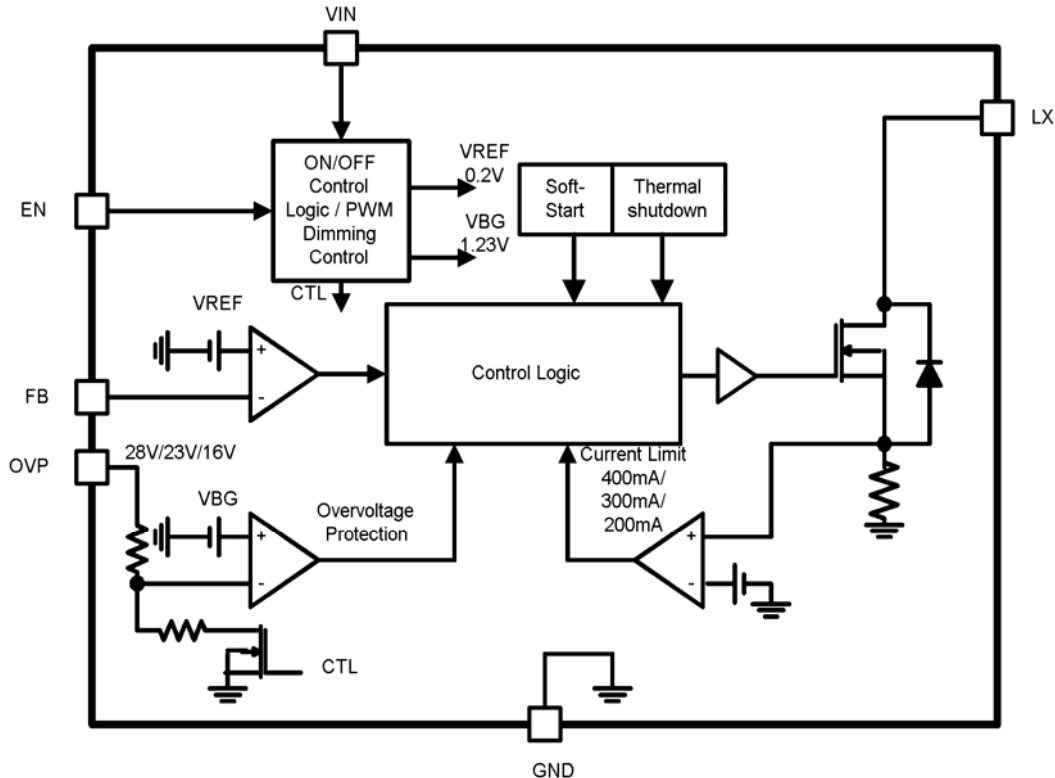

**Aimtron reserves the right without notice to change this circuitry and specifications.**

**Pin Configuration**

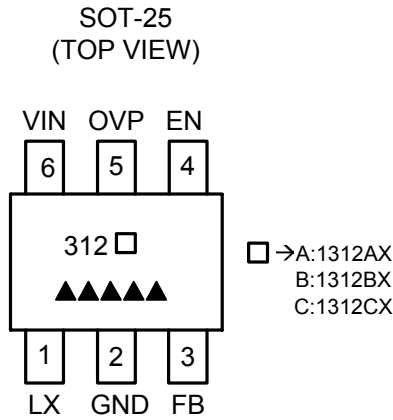

**Ordering Information**

Part number	Package	Current Limit	OVP Protection	Marking
AT1312AX	SOT-26	400mA	28V	▲▲▲▲▲ Date Code
AT1312AX_GRE	SOT-26, Green	400mA	28V	▲▲▲▲▲ —————,Date Code with one bottom line
AT1312BX	SOT-26	300mA	23V	▲▲▲▲▲ Date Code
AT1312BX_GRE	SOT-26, Green	300mA	23V	▲▲▲▲▲ —————,Date Code with one bottom line
AT1312CX	SOT-26	200mA	16V	▲▲▲▲▲ Date Code
AT1312CX_GRE	SOT-26, Green	200mA	16V	▲▲▲▲▲ —————,Date Code with one bottom line

▲▲▲▲▲ : Date Code

*\*For more marking information, contact our sales representative directly*

**Pin Description**

Pin NO.	Symbol	I / O	Description
1	LX	I	Step-up Regulator N-MOS Drain. Place output diode and inductor.
2	GND	P	Ground
3	FB	I	Step-Up Regulator Feedback Input. Connect a sense resistor from FB to ground.
4	EN	I	Enable and Dimming Control Input. LED brightness and IC shutdown are controlled by the voltage on EN. Driving low for longer than 4ms to shutdown the IC.
5	OVP	I	Over-voltage protection input. Connect to the output.
6	VIN	P	Power supply.

**Absolute Maximum Ratings\*1**

Parameter	Rated Value	Unit	
VIN voltage	-0.3 to +6.5	V	
LX , OVP voltage	-0.3 to +28	V	
EN , FB to GND	-0.3 to +6.5	V	
Switch Current (ILX)	0.6	A	
Continuous power dissipation (SOT-26 Ta=+25°C)	0.35	W	
Operating Junction Temperature Range	-30 to 85	°C	
Lead Temperature (Soldering 5 sec)	260	°C	
Storage Temperature	-65 to 125	°C	
Package Thermal Resistance ( $\Theta_{JA}$ )	250	°C/W	
ESD Susceptibility*2	HBM	2	KV
	MM	200	V

1. Stresses beyond those listed under “Absolute Maximum Ratings” may cause permanent damage to the device. These are stress ratings only, and functional operation of the device at these or any other conditions beyond those indicated in the operational sections of the specifications is not implied. Exposure to absolute maximum rating conditions for extended periods may affect device reliability.
2. Device are ESD sensitive. Handling precaution recommended. The Human Body model is a 100pF capacitor discharged through a 1.5K $\Omega$  resistor into each pin.

**Recommended Operation Conditions**

Parameter	Symbol	Values			Unit
		Min.	Typ.	Max.	
Power supply voltage	V <sub>IN</sub>	2.5	—	6.0	V
Operating temperature	Top	-20	+25	+85	°C

**Electrical Characteristics**

 ( $V_{IN}=2.5V$ ,  $T_a=+25^{\circ}C$ , unless otherwise noted)

Parameter	Symbol	Test Condition	Min.	Typ.	Max.	Units
Operating $V_{IN}$ Range	$V_{IN}$	$V_{IN}$ input Voltage	2.5	-	6.0	V
Under Voltage Thershold	UVLO	$V_{IN}$ falling, 100mV hysteresis	2.1	2.2	2.3	V
Switch- Off Input Current	$I_{IN1}$	No Switching	-	100	120	$\mu A$
Shutdown Current	$I_{IN3}$	EN=0V	-	-	1	$\mu A$
Feedback Reference	$V_{FB}$		0.190	0.2	0.210	V
FB Input Bias Current	$I_{FB}$	$V_{FB}=0.2V$	-	-	1	$\mu A$
Over-voltage Threshold	$V_{OVP}$	$V_{OUT}$ Rising (AT1312A)	-	28	-	V
		$V_{OUT}$ Rising (AT1312B)	-	23	25	V
		$V_{OUT}$ Rising (AT1312C)	-	16	18	V
Over-voltage Hysteresis			2		V	
OVP Leakage Current	$I_{OVP}$	EN=0V	-	-	1	$\mu A$
Output Voltage Line Regulation		$2.5V < V_{IN} < 6.0V$	-	0.1	-	%
Switching Frequency	$f_{OSC}$		-	1	-	MHz
Maximum Duty	$D_{MAX}$		-	90	-	%
Soft-Start charging time	$t_{SS}$		0.05	0.5	-	ms
Switching Current Limit	$I_{LX}$	$V_{IN}=3.0V$ ,duty cycle=80% , (AT1312A)	-	400	-	mA
		$V_{IN}=3.0V$ ,duty cycle=80% , (AT1312B)	-	300	-	mA
		$V_{IN}=3.0V$ ,duty cycle=80% , (AT1312C)	-	200	-	mA
LX ON Resistance	$R_{LX}$	$V_{IN}=2.5V$ , $I_{LX}=200mA$	-	0.3	-	$\Omega$
LX Leakage Current	$I_{Leakage}$	$V_{LX}=16V/23V/28V$ , EN=0V	-	-	5	$\mu A$
EN Input Current	$I_{EN}$	EN=5V	-	-	1	$\mu A$
EN Input Level	$V_{IH}$	0.1V hysteresis	2.0	-	-	V
	$V_{IL}$		-	-	0.8	V
EN low Shutdown Delay			-	4	-	ms
EN Low Cycle Time	$t_{CYCL}$	*1	0.05	-	5	ms
EN High Cycle Time	$t_{CYCH}$	*1	0.05	-	5	ms
Thermal Shutdown			-	120	-	$^{\circ}C$

 \*1:  $t_{CYCL}$  and  $t_{CYCH}$  are included rising time and falling time of PWM signal.

**Typical Characteristics**

**Conversion Efficiency**  
L:SR0302 D:RB501-40

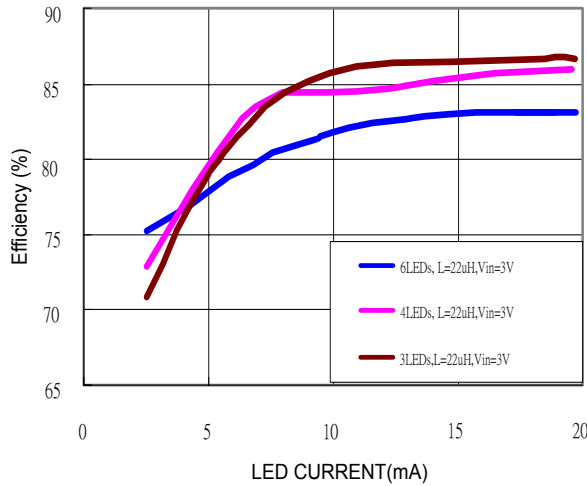

**Efficiency vs. Vin (3 LED)**  
L:SR0302 D:RB501-40

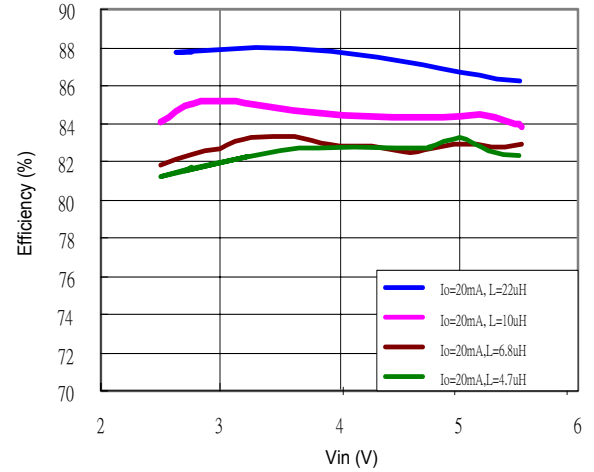

**Efficiency vs. Vin (4 LED)**  
L:SR0302 D:RB501-40

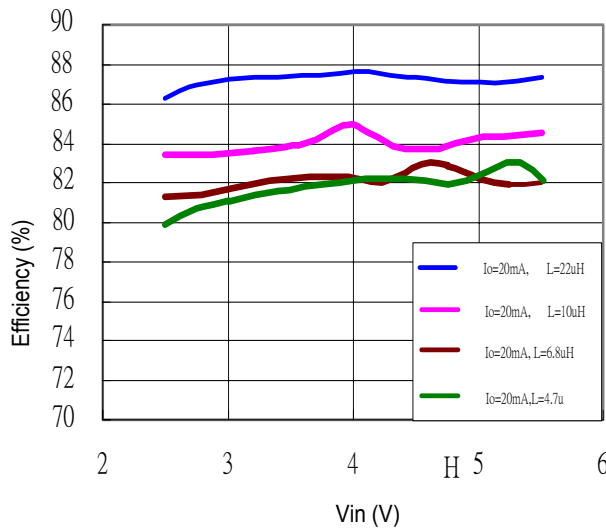

**Efficiency vs. Vin (6 LED)**  
L:SR0302 D:RB501-40

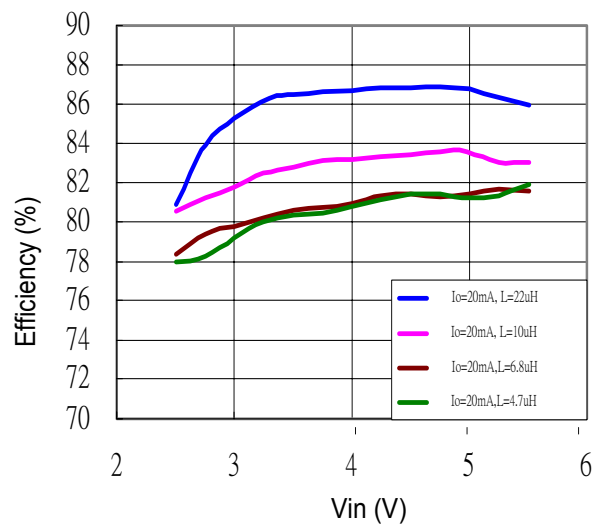

**Efficiency vs. Vin (6 LED)**  
**L:SR0302 D:RB501-40**

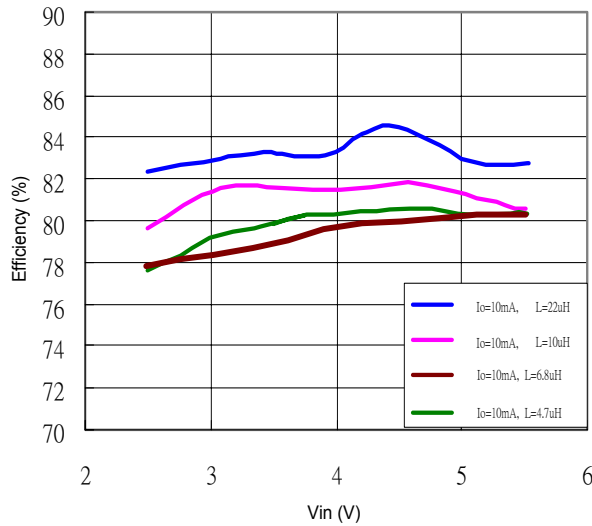

**Efficiency vs. Vin (4 LED)**  
**L:SR0302 D:RB501-40**

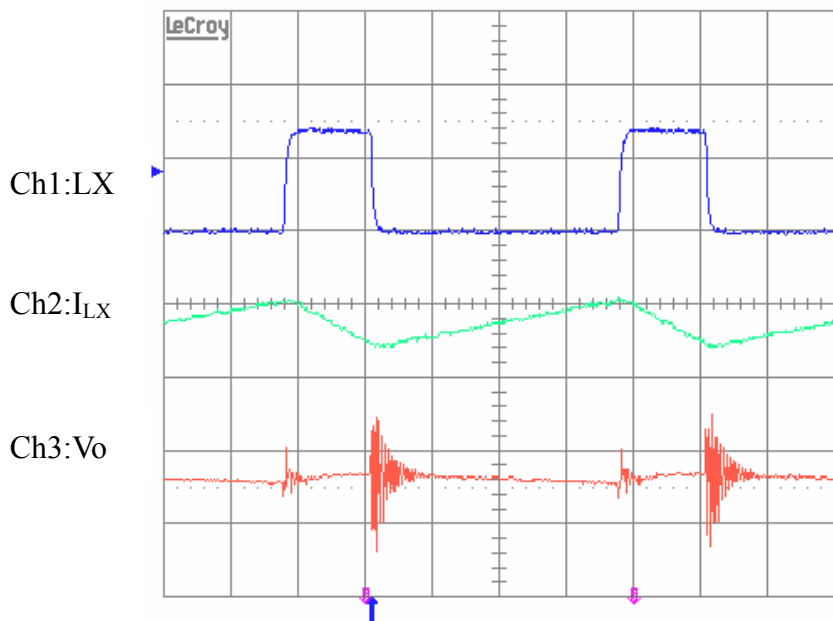
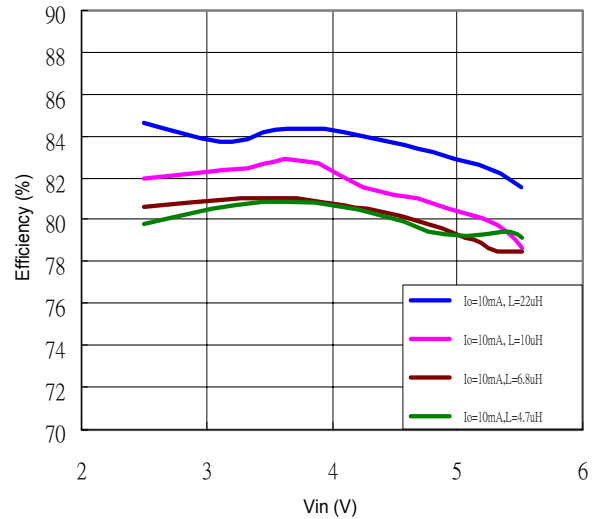

Ch1:LX :10V/div , Ch2:ILX: 200mA/div, Ch3: Vo :100mV/div ,0.2uS/div

**Switching Transient Waveform**

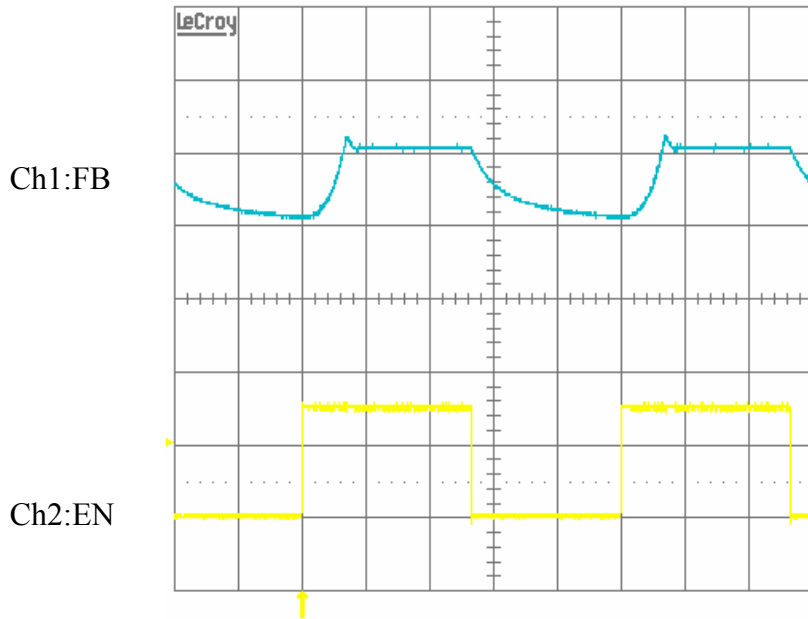

Ch1:FB : 200mV/div , Ch2:ENABLE: 2V/div , 0.2mS/div

**PWM Dimming Control Using the EN Pin**

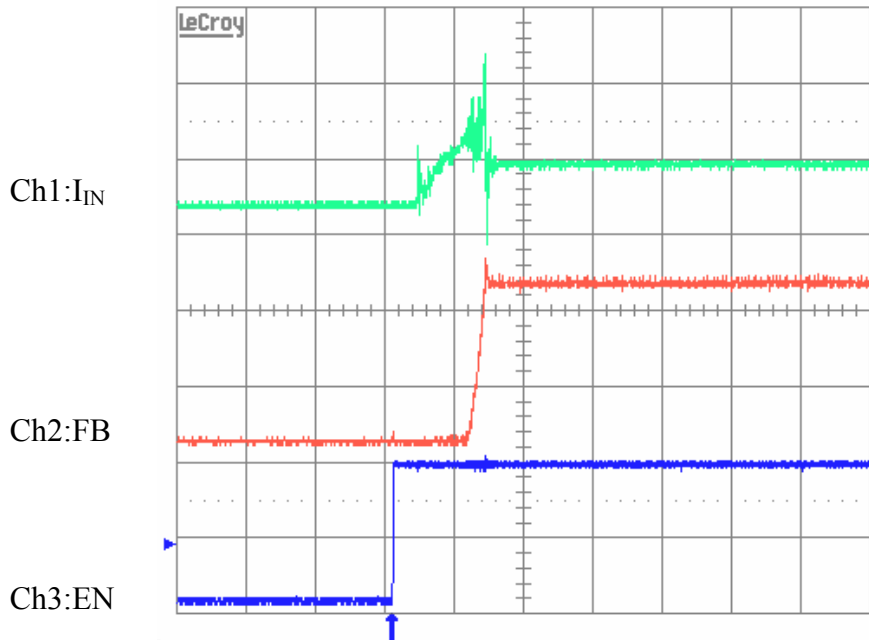

Ch1:IN : 200mA/div , Ch2:FB: 100mV/div , Ch3:ENABLE:2V/div , 0.5mS/div

**Start-Up Waveform**

**Application Circuit**

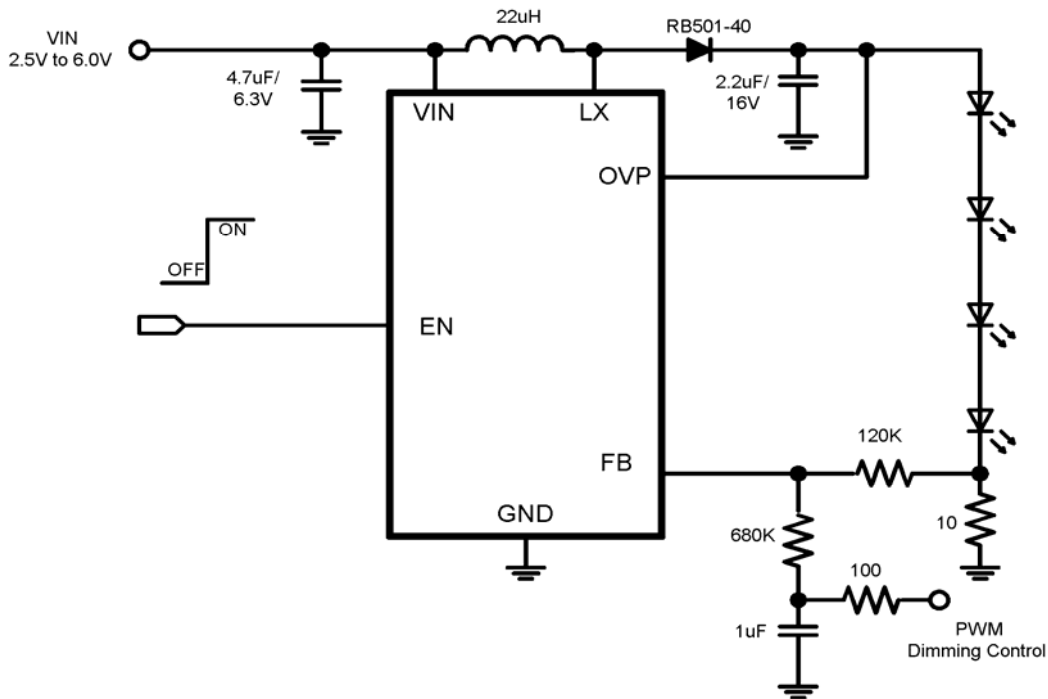
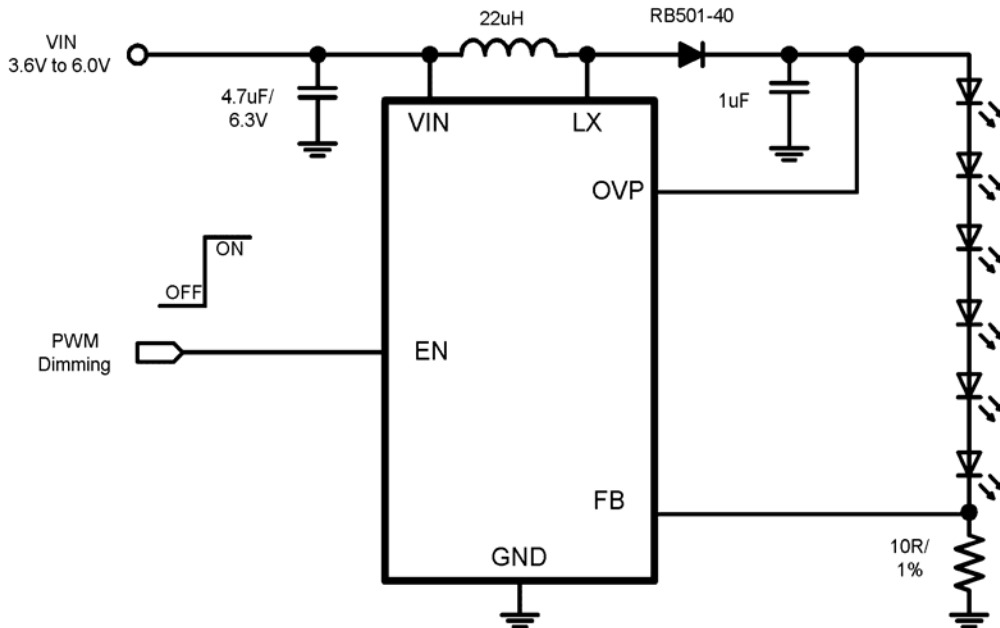

*※ Use the tantalum capacitor to eliminate inductor noise on output terminal when you want to control dimming function.*



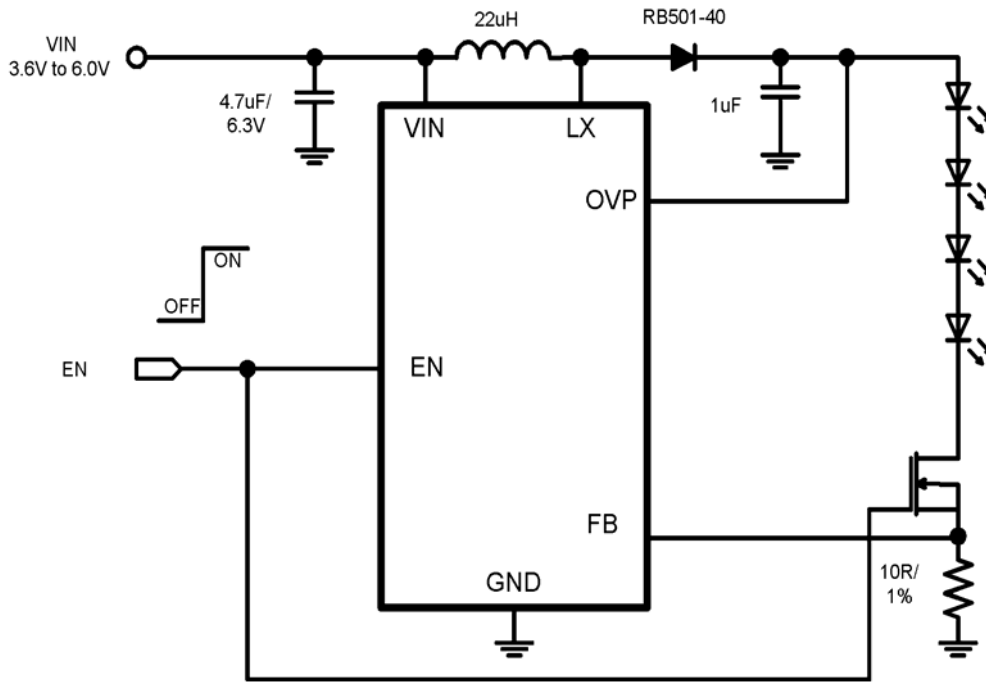

**Prevent Emission Caused by White LEDs Leakage**

## Function Description

The AT1312 series are high efficiency and constant current DC-DC converter IC which is designed primarily for use in LED module applications. The output voltage of the step-up converter can be set from  $V_{in}$  to 16V/23V/28V with external sense resistor. The device suits to drive series-connected LEDs and provides even illumination by sourcing the same output current through each LED. AT1312 series also consists of a logic shutdown, cycle-by-cycle current-limited, soft-start functions. Logic control input or PWM duty cycle control allows easy adjustment of LEDs brightness and on/off control. The average LED current is proportional to the duty-cycle of the PWM signal. Typical PWM frequency should be between 100Hz and 1KHz.

The boost converter operates in current-mode PWM and a constant frequency of 1.0 MHz. Depending on duty cycle of each switching cycle can regulate output voltage. On the rising edge of the internal clock, the control and driver logic block sets internal flip-flop when the output voltage is too low, which turns on the N-MOS. The external inductor current ramps up linearly, storing energy in a magnetic field. Once peak current of inductor over trans-conductance output level, the N-MOS turns off, the flip-flop resets, and external schottky diode turns on. This forces the current through the inductor to ramp back down, transferring the energy stored in the magnetic field to the output capacitor and LEDs. To reduce external components, the device will be built-in internal loop compensation.

## Enable Control

Digital logic of EN provides an electrical ON/OFF control of the power supply. Connecting this pin to ground or to any voltage less than 0.7V and sustain the level over 4ms will completely turn off the regulator. In this state, current drain from the input supply is less than 1uA, the internal reference, error amplifier, comparators, and biasing circuitry turn off. If holding time of low level is less than 3ms on this pin, then the device only shutdown driver logic block.

## Dimming Control

Digital logic of EN also provides LEDs brightness control by applying a PWM signal on EN pin. With this way, the LEDs operate with either zero or full current. The average LED current is proportional to the duty-cycle of the PWM signal. Typical PWM frequency should be between 100Hz and 1KHz. Output current is given by:

$$I_{LED} = \frac{200mV \times T_{ON-PWM}}{R_{SENSE} \times T_{S-PWM}}$$

Where:

$T_{ON-PWM}$  : On time of PWM signal

$T_{S-PWM}$  : A cycle time of PWM signal

If dimming control is not required , EN works as a simple on/off control. Drive EN

high to enable the device , or drive EN low for shutdown.

### **Soft-Start**

Soft-start allows a gradual increase of the internal current-limit level for the step-up converter during power-up to reduce input surge currents. As the internal current source charges the internal soft-start capacitor, the peak N-MOS current is limited by the voltage on the capacitor. In another story, when toggle or a logic-level transition on EN pin from low to high, soft-start function must work to enable constant current charging internal capacitor. When soft-start process has finished or appeared falling edge of PWM signal on EN pin, soft-start capacitor must be discharged to ground level.

### **Cycle-by-Cycle Over-Current Protection**

The AT1312 series provides cycle-by-cycle over-current protection. Current limit is accomplished using a separate dedicated comparator. The cycle-by-cycle current limit abbreviates the on-time of the N-MOS in event that the current of flowing N-MOS is greater than the current limit value. The current-limit feature protection against a hard short or over-current fault at the output.

### **Over-Voltage Protection**

If  $V_{OUT}$  is above 16V/23V/28V( for AT1312A/B/C) or LEDs are disconnected from the circuit, the FB pin is similar to pull down to ground with a sense resistor. This will cause N-MOS to switch with a maximum duty cycle and come out output over-voltage. This may cause the LX pin voltage to exceed its maximum voltage rating to damage built-in N-MOS. In the state, the OVP protection circuitry stops the internal N-MOS. When  $V_{OUT}$  falls below 14V/21V/26V, IC will automatically recover normal operation.

### **Thermal-Overload Protection**

Thermal-overload protection limits total power dissipation in the AT1312 series. When the junction temperature exceeds  $T_j=130\text{ }^\circ\text{C}$ , a thermal sensor activates the thermal protection, which shuts down the IC, allowing the IC to cool. Once the device cools down by  $10\text{ }^\circ\text{C}$ , IC will automatically recover normal operation. For continuous operation , do not exceed the absolute maximum junction-temperature rating of  $T_j=120\text{ }^\circ\text{C}$ .

### **Power dissipation consideration**

The AT1312 series maximum power dissipation depends on the thermal resistance of the IC package and circuit board, the temperature difference between the die junction and ambient air, and the rate of any airflow. The power dissipation in the device depends on the operating conditions of the regulator. In continuous condition, the step-up converter power dissipated internally across the internal N-MOS can be approximated by :

$$P_{boost} = \left[ \left( \frac{I_O \times V_O}{V_{in}} \right)^2 + \frac{1}{12} \left( \frac{V_{in} \times D}{f_{OSC} \times L} \right)^2 \right] \times R_{DS(ON)} \times D$$

where

$I_O$  : It is the load current.

$f_{OSC}$  : It is a switching frequency.

## Application Information

External components of boost converter can be designed by performing simple calculations.

### Boost inductor

Inductor selection depends on input voltage, output voltage, maximum output current, switching frequency and availability of inductor values. The following boost circuit equations are useful in choosing the inductor values based on the application. They allow the trading of peak current and inductor value while allowing for consideration of component availability and cost.

The peak inductor current is given by:

$$I_{L_{peak}} = I_{L_{AVG}} + \frac{\Delta I_L}{2}$$

$$I_{L_{AVG}} = \frac{I_o}{1-D}$$

where:

$\Delta I_L$  is the inductor peak-to-peak current ripple and is decided by:

$$\Delta I_L = \frac{V_{in}}{L} \times \frac{D}{f_{OSC}}$$

D is the MOSFET turn on ratio and is decided by:

$$D = \frac{V_o - V_{in}}{V_o}$$

$f_{OSC}$  is the switching frequency.

The inductor should be chosen to be able to handle this current and inductor saturation current rating should be greater than  $I_{PEAK}$ .

### Diode selection

The output diode has average current of  $I_o$ , and peak current the same as the inductor's peak current and a voltage rating at least 1.5 times the output voltage. Schottky diode is recommended and it should be able to handle those current.

### Output Capacitor

The AT1312 series are specially compensated to be stable with capacitors which have a worst- case minimum value of 1uF at the particular  $V_{OUT}$  being set. Output ripple voltage requirements also determine the minimum value and type of capacitors. Output ripple voltage consists of two components the voltage drop caused by the switching current through the ESR of the output capacitor and the charging and discharging of the output capacitor:

$$V_{RIPPLE} = I_{L_{PEAK}} \times ESR + \frac{V_o - V_{in}}{V_o} \times \frac{I_o}{C_{OUT} \times f_{OSC}}$$

For low ESR ceramic capacitors, the output ripple is dominated by the charging or discharging of the output capacitor.

### **PCB layout guidelines**

Careful printed circuit layout is extremely important to avoid causing parasitical capacitance and line inductance. The following layout guidelines are recommended to achieve optimum performance.

- Please the boost converter diode and inductor close to the LX pin and no via. Keep traces short, direct, and wide.
- Please ceramic bypass capacitors near the input/output pin.
- Locate all feedback sense resistors as close to the feedback pins as possible.
- The ground connections of  $V_{IN}$  and  $V_{OUT}$  should be as close together as possible.

**Small Outline SOT-26**

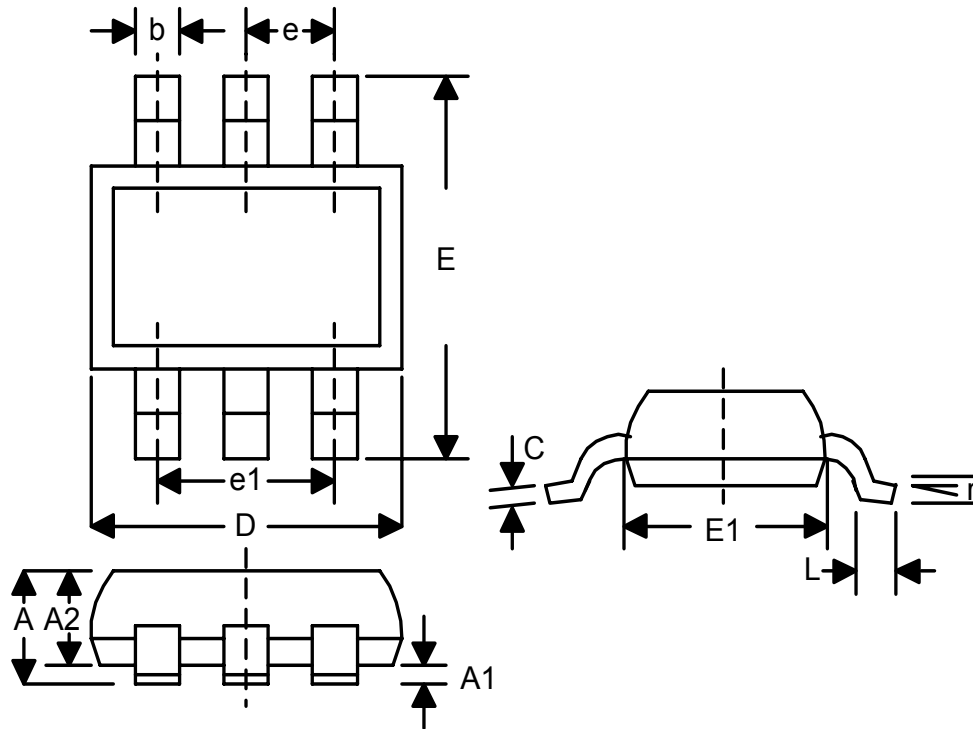

SYMBOL	INCHES		MILLIMETERS		NOTES
	MIN	MAX	MIN	MAX	
A	0.035	0.057	0.90	1.45	-
A1	0.000	0.006	0.00	0.15	-
A2	0.035	0.051	0.90	1.30	-
b	0.010	0.020	0.25	0.50	-
C	0.003	0.008	0.08	0.20	-
D	0.110	0.122	2.80	3.10	-
E	0.102	0.118	2.60	3.00	-
E1	0.059	0.069	1.50	1.75	-
L	0.014	0.022	0.35	0.55	-
e	0.037ref		0.95ref		
e1	0.075ref		1.90ref		
r	0 <sup>0</sup>	10 <sup>0</sup>	0 <sup>0</sup>	10 <sup>0</sup>	-

**Reflow Profiles**

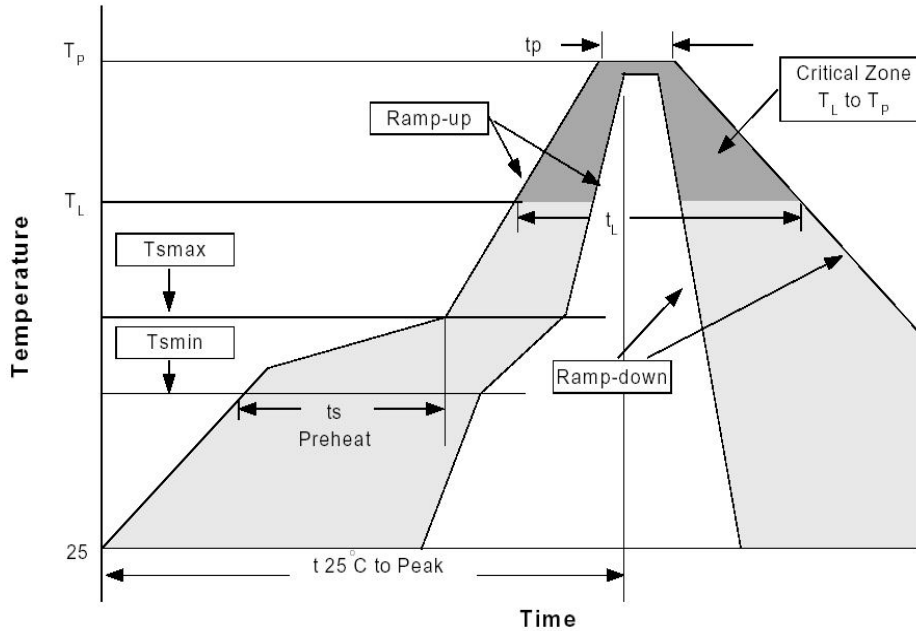

Profile Feature	Sn-Pb Eutectic Assembly		Pb-Free Assembly	
	Large Body Pkg. thickness ≥2.5mm or Pkg. volume ≥350mm <sup>3</sup>	Small Body Pkg. thickness <2.5mm or Pkg. volume <350mm <sup>3</sup>	Large Body Pkg. thickness ≥2.5mm or Pkg. volume ≥350mm <sup>3</sup>	Small Body Pkg. thickness ≥2.5mm or Pkg. volume ≥350mm <sup>3</sup>
Average ramp-up rate (T <sub>L</sub> to T <sub>P</sub> )	3°C/second max.		3°C/second max.	
Preheat -Temperature Min(T <sub>min</sub> ) -Temperature Max (T <sub>max</sub> ) -Time (min to max)(t <sub>s</sub> )	100°C 150°C 60-120 seconds		150°C 200°C 60-180 seconds	
T <sub>max</sub> to T <sub>L</sub> -Ramp-up Rate			3°C/second max.	
Time maintained above: -Temperature (T <sub>L</sub> ) -Time (t <sub>L</sub> )	183°C 60-150 seconds		217°C 60-150 seconds	
Peak Temperature(T <sub>P</sub> )	225+0/-5°C	240+0/-5°C	245+0/-5°C	250+0/-5°C
Time within 5°C of actual Peak Temperature (t <sub>p</sub> )	10-30 seconds	10-30 seconds	10-30 seconds	20-40 seconds
Ramp-down Rate	6°C/second max.		3°C/second max.	
Time 25°C to Peak Temperature	6 minutes max.		8 minutes max.	

\*All temperatures refer to topside of the package, measured on the package body surface.