



HLM358P / HLM358S

LOW POWER DUAL OPERATIONAL AMPLIFIERS

Description

These devices consist of two independent, high gain, internally frequency-compensated operational amplifiers designed to operate from a single supply over a wide range of voltages. Operation from split supplies also is possible if the difference between the two supplies is 3V to 32V, and V_{CC} is at least 1.5V more positive than the input common-mode voltage. The low supply-current drain is independent of the magnitude of the power supply voltage.

Features

- Two internally compensated OP amps
- Internally frequency compensated for unity gain
- Short Circuit Protected Outputs
- Wide power supply range: $3V_{DC}$ to $32V_{DC}$ (Single supply)
- Input common-mode voltage range includes ground
- Large output voltage swing: $0V_{DC}$ to $V_{CC}-1.5V_{DC}$

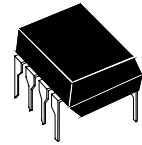

8-Lead Plastic **DIP-8**
 Package Code: P

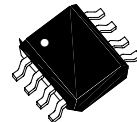

8-Lead Plastic **SO-8**
 Package Code: S

Logic Diagram (each amplifier)

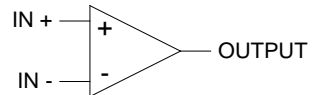

Pin Configurations

	Pin 1: Output 1	Pin 5: Non Inverting Input 2
	Pin 2: Inverting Input 1	Pin 6: Inverting Input 2
	Pin 3: Non Inverting Input 1	Pin 7: Output 2
	Pin 4: V_{EE}	Pin 8: V_{CC}

Schematic Diagram

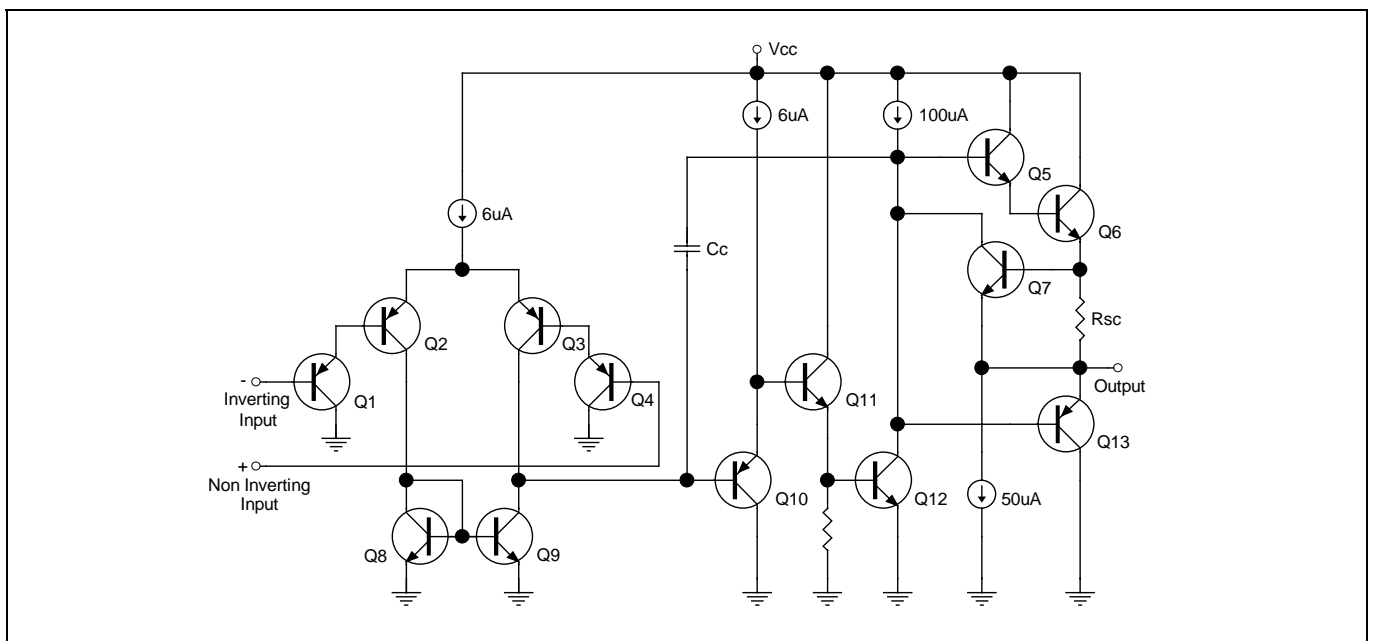



Absolute Maximum Ratings (Ta=25°C, unless otherwise specified)

Symbol	Parameter	Range	Units
V _{CC}	Power Supply Voltage (Single Supply)	32	V _{DC}
V _{CC} , V _{EE}	Power Supply Voltage (Split Supplies)	±16	V _{DC}
V _{IDR}	Input Differential Voltage Range	±32	V _{DC}
V _{ICR}	Input Common Mode Voltage Range	-0.3 to +32	V _{DC}
t _{SC}	Output Short Circuit Duration	Continuous	
T _J	Junction Temperature	150	°C
T _{stg}	Storage Temperature Range	-55 to +125	°C
T _A	Operating Ambient Temperature Range	0 to +70	°C
P _D	Maximum Power Dissipation (DIP-8) Maximum Power Dissipation (SO-8)	800 500	mW

Electrical Characteristics (V_{CC}=5V, V_{EE}=Ground, Ta=25°C, unless otherwise specified)

Symbol	Parameter	Test Conditions	HLM358P/S			Unit
			Min	Typ	Max	
V _{IO}	Input Offset Voltage	V _{CC} =5V~30V, V _{ICR} =0V~V _{CC} -1.5V, V _O =1.4V, R _S =0Ω	-	2	7	mV
I _{IO}	Input Offset Current	I _{IN(+)} -I _{IN(-)}	-	-	30	nA
I _{IB}	Input Bias Current	I _{IN(+)} or I _{IN(-)}	-	35	200	nA
A _{VOL}	Large Signal Voltage Gain	V _{CC} =15V, R _L =2KΩ	25	100	-	V/mV
CMR	Common-Mode Rejection Ratio	V _{CM} =0V~V _{CC} -1.5V	65	85	-	dB
CS	Channel Separation	1KHz≤f≤20KHz	-	-120	-	dB
PSR	Power Supply Rejection	V _{CC} =5V~30V	65	100	-	dB
ΔV _{IO} /ΔT	Average Temperature Coefficient of Input Offset Voltage	R _S =0Ω	-	7	-	uV/°C
ΔI _{IO} /ΔT	Average Temperature Coefficient of Input Offset Current	R _S =0Ω	-	10	-	pA/°C
V _{ICR}	Input Common Mode Voltage Range	V _{CC} =30V			V _{CC} -2V	V
V _{OH}	Output Voltage (High Limit)	V _{CC} =30V, R _L =2KΩ	26	27	-	V
		V _{CC} =30V, R _L =10KΩ	27	28	-	
V _{OL}	Output Voltage (Low Limit)	R _L =10KΩ	-	5	20	mV
I _{CC}	Supply current	R _L =∞, V _{CC} =30V	-	1	2	mA
I _{Source}	Output Source Current	V _{CC} =15V, V _{IN+} =1V, V _{IN-} =0V, V _O =2V	20	40	-	mA
I _{Sink}	Output Sink Current	V _{CC} =15V, V _{IN+} =0V, V _{IN-} =1V, V _O =2V	10	20	-	mA
I _{CC}	Power Supply Current	V _{CC} =30V, Ta=T _{high} to T _{low}	-	1	2	mA
		V _{CC} =5V, Ta=T _{high} to T _{low}	-	0.6	1.2	mA
I _{SC}	Output Short Circuit to Ground	V _{CC} =5V, GND at -5V, V _O =0V	-	40	60	mA



Characteristics Curve

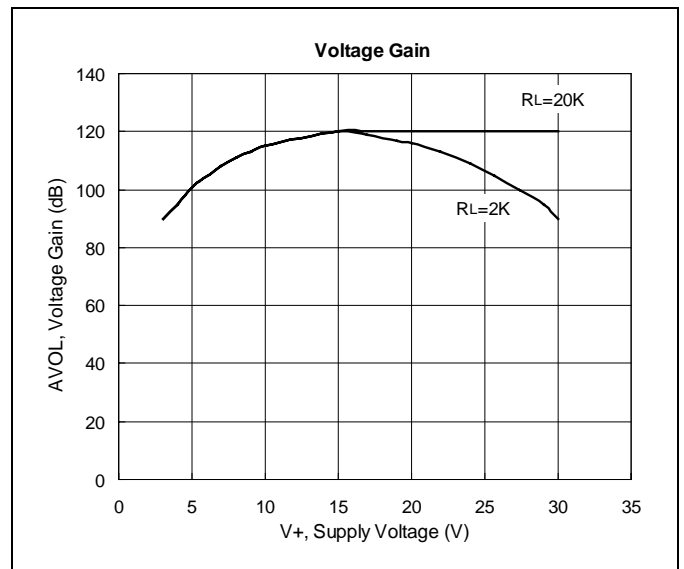
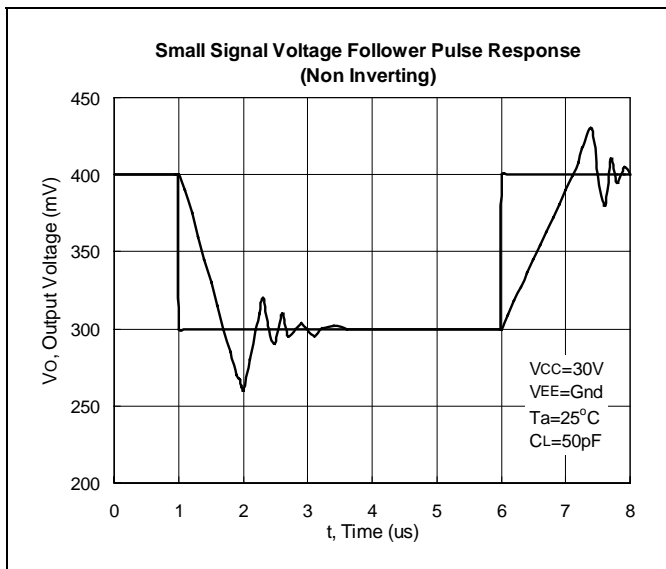
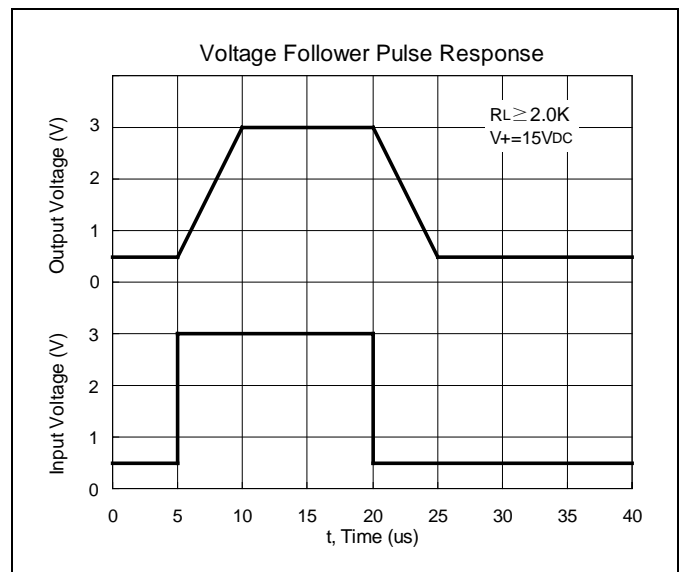
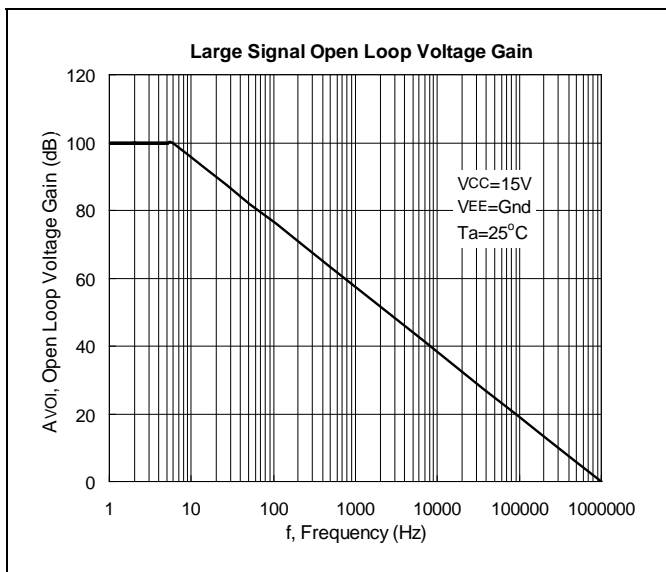
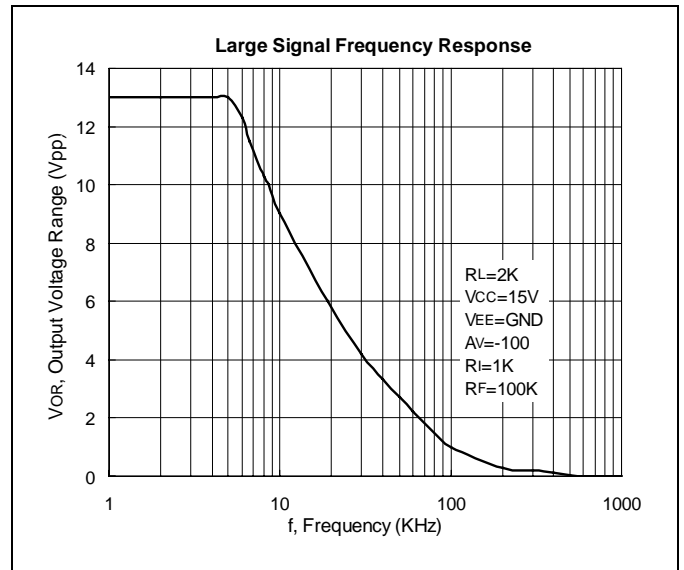
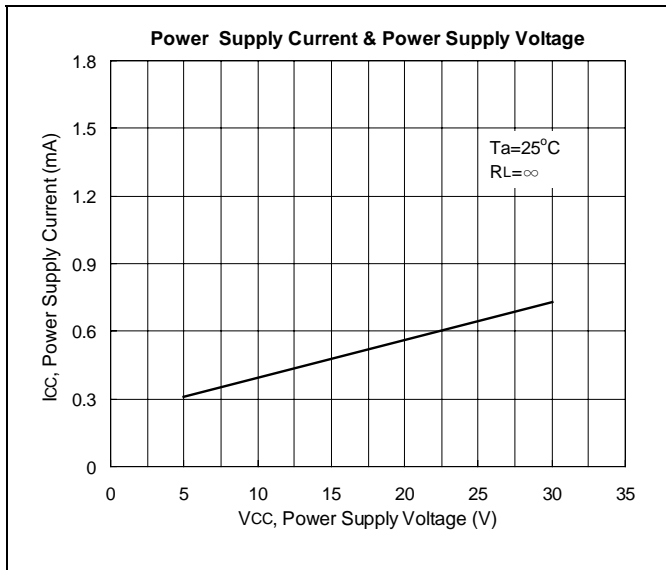



Characteristics Curve

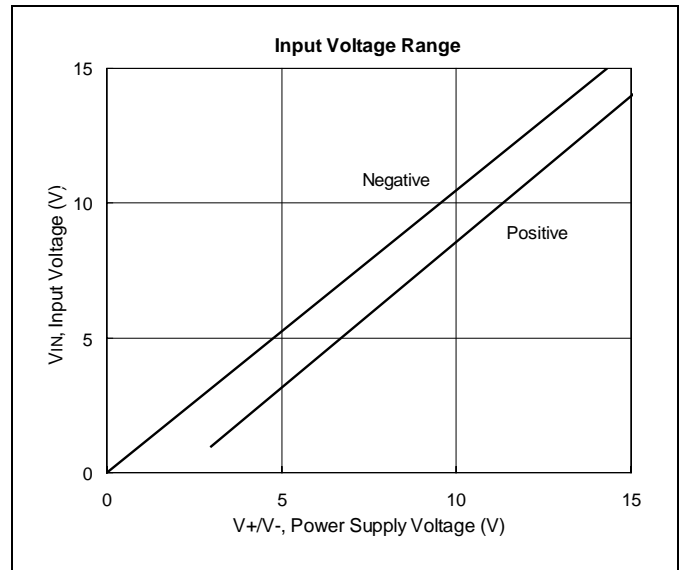
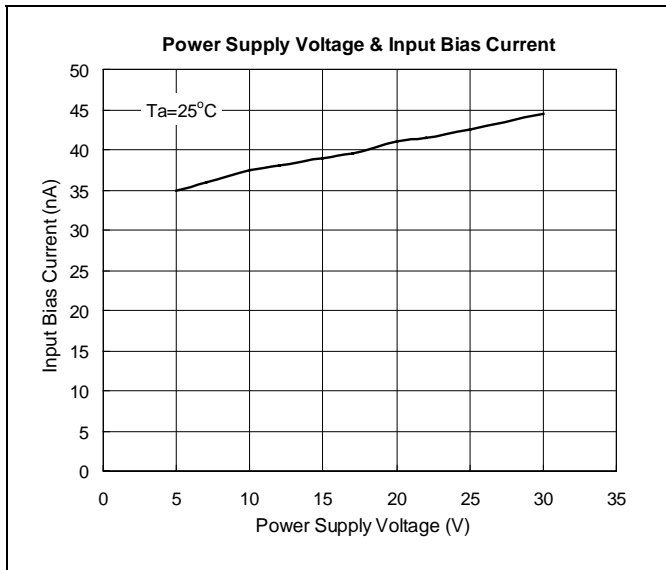

Typical Application Circuit

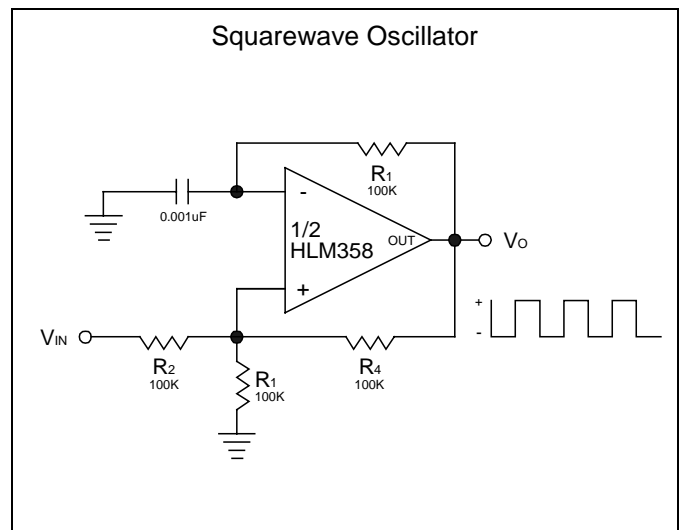
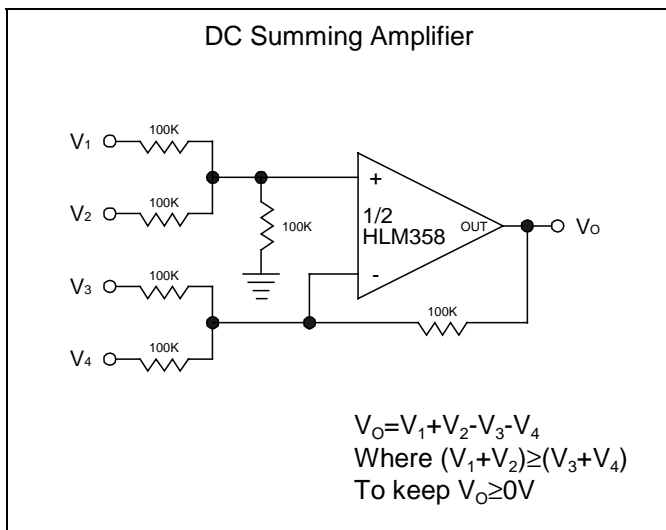
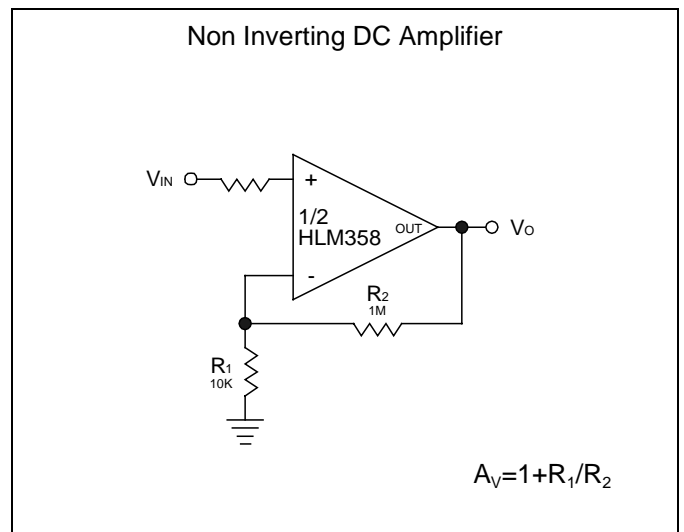
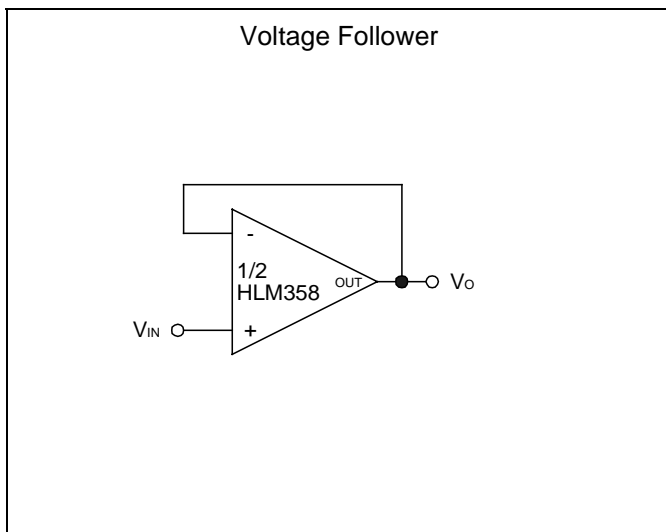



Typical Application Circuit

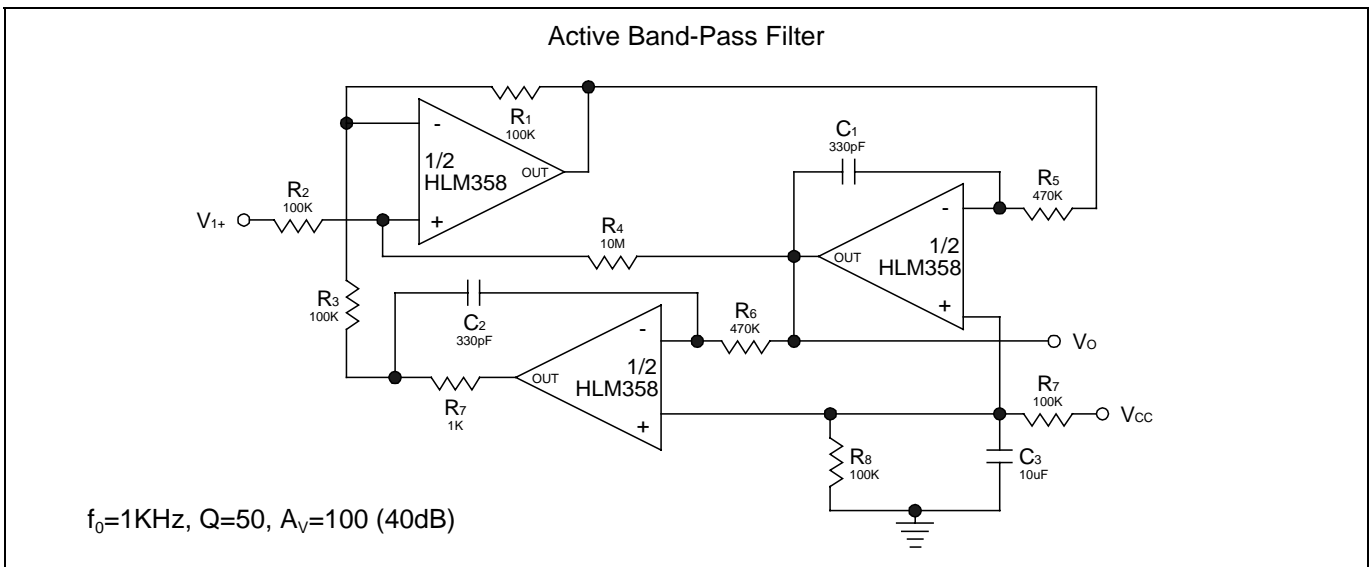
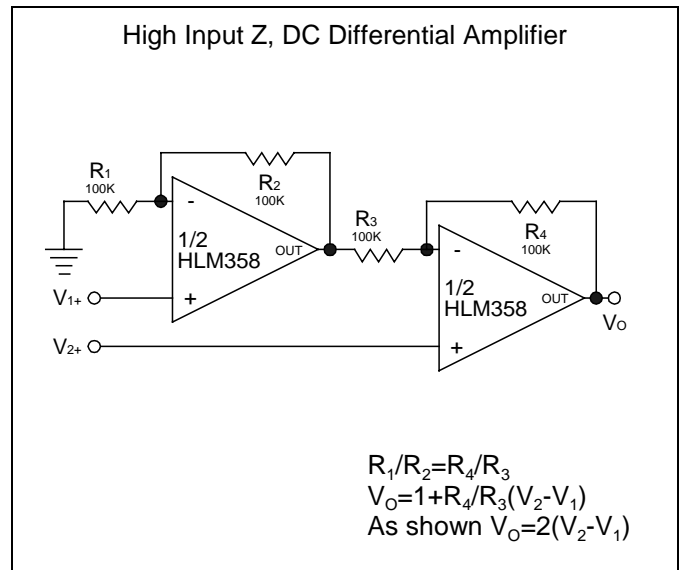
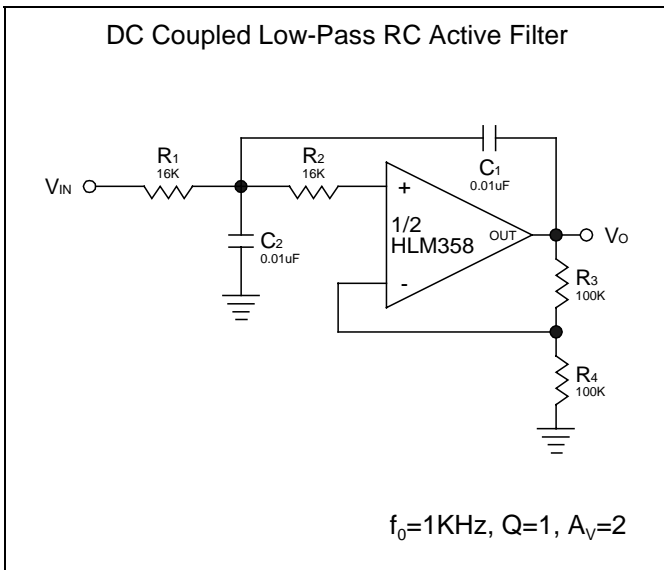
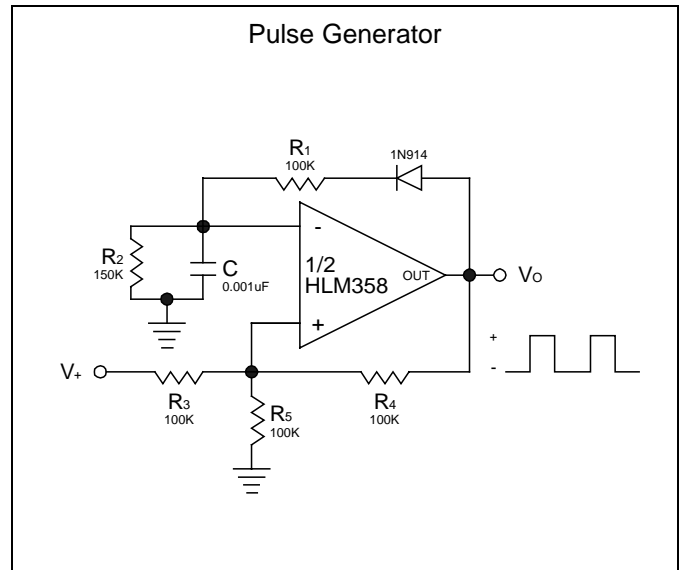
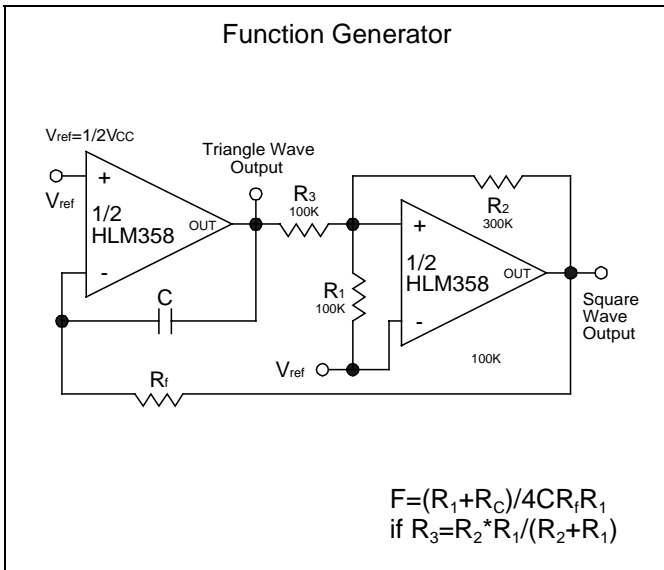



DIP-8 Dimension

8-Lead DIP-8
Plastic Package
HSMC Package Code: P

Marking:

Pb Free Mark
 Pb-Free: " " (Note)
 Normal: None

Note: Green label is used for pb-free packing

Pin Style: 1. Output 1 2. Inverting input 1 3. Non inverting input 1 4. V_{EE}
 5. Non inverting input 2 6. Inverting input 2 7. Output 2 8. V_{CC}

Material:

- Lead solder plating: Sn60/Pb40 (Normal), Sn/3.0Ag/0.5Cu or Pure-Tin (Pb-free)
- Mold Compound: Epoxy resin family, flammability solid burning class: UL94V-0

DIM	Min.	Max.
A	6.29	6.40
B	9.22	9.32
C	-	*1.52
D	-	*1.27
E	-	*0.99
F	3.25	3.35
G	3.17	3.55
H	0.38	0.53
I	2.28	2.79
J	7.49	7.74
K	-	*3.00
L	8.56	8.81
M	0.229	0.381
α1	94°	97°

*: Typical, Unit: mm

SO-8 Dimension

8-Lead SO-8 Plastic
Surface Mounted Package
HSMC Package Code: S

Marking:

Pb Free Mark
 Pb-Free: "●" (Note)
 Normal: None

Note: Green label is used for pb-free packing

Pin Style: 1. Output 1 2. Inverting input 1 3. Non inverting input 1 4. V_{EE}
 5. Non inverting input 2 6. Inverting input 2 7. Output 2 8. V_{CC}

Material:

- Lead solder plating: Sn60/Pb40 (Normal), Sn/3.0Ag/0.5Cu or Pure-Tin (Pb-free)
- Mold Compound: Epoxy resin family, flammability solid burning class: UL94V-0

DIM	Min.	Max.
A	4.85	5.10
B	3.85	3.95
C	5.80	6.20
D	1.22	1.32
E	0.37	0.47
F	3.74	3.88
G	1.45	1.65
H	4.80	5.10
I	0.05	0.20
J	0.30	0.70
K	0.19	0.25
L	0.37	0.52
M	0.23	0.28
N	0.08	0.13
O	0.00	0.15

*: Typical, Unit: mm

Important Notice:

- All rights are reserved. Reproduction in whole or in part is prohibited without the prior written approval of HSMC.
- HSMC reserves the right to make changes to its products without notice.
- **HSMC semiconductor products are not warranted to be suitable for use in Life-Support Applications, or systems.**
- HSMC assumes no liability for any consequence of customer product design, infringement of patents, or application assistance.

Head Office And Factory:

- **Head Office** (Hi-Sincerity Microelectronics Corp.): 10F., No. 61, Sec. 2, Chung-Shan N. Rd. Taipei Taiwan R.O.C.
 Tel: 886-2-25212056 Fax: 886-2-25632712, 25368454
- **Factory 1:** No. 38, Kuang Fu S. Rd., Fu-Kou Hsin-Chu Industrial Park Hsin-Chu Taiwan. R.O.C
 Tel: 886-3-5983621~5 Fax: 886-3-5982931



Soldering Methods for HSMC's Products

1. Storage environment: Temperature=10°C~35°C Humidity=65%±15%
2. Reflow soldering of surface-mount devices

Figure 1: Temperature profile

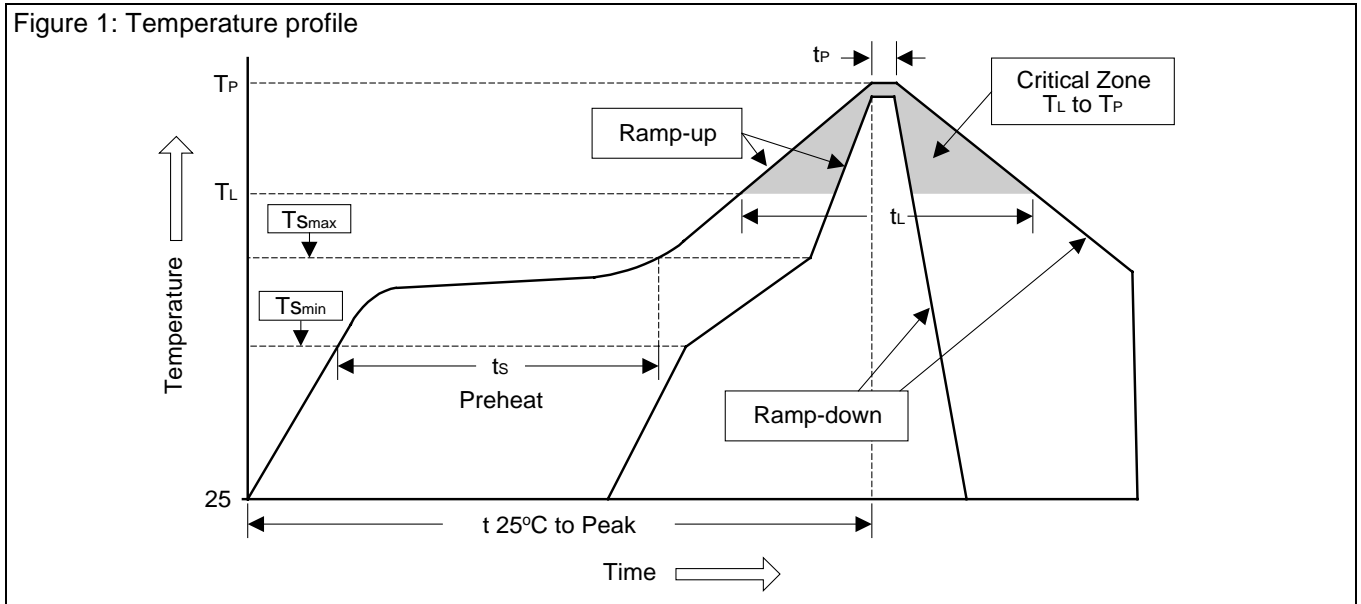

Profile Feature	Sn-Pb Eutectic Assembly	Pb-Free Assembly
Average ramp-up rate (T_L to T_P)	<3°C/sec	<3°C/sec
Preheat		
- Temperature Min (T_{Smin})	100°C	150°C
- Temperature Max (T_{Smax})	150°C	200°C
- Time (min to max) (t_s)	60~120 sec	60~180 sec
T_{Smax} to T_L		
- Ramp-up Rate	<3°C/sec	<3°C/sec
Time maintained above:		
- Temperature (T_L)	183°C	217°C
- Time (t_L)	60~150 sec	60~150 sec
Peak Temperature (T_P)	240°C +0/-5°C	260°C +0/-5°C
Time within 5°C of actual Peak Temperature (t_P)	10~30 sec	20~40 sec
Ramp-down Rate	<6°C/sec	<6°C/sec
Time 25°C to Peak Temperature	<6 minutes	<8 minutes

3. Flow (wave) soldering (solder dipping)

Products	Peak temperature	Dipping time
Pb devices.	245°C ±5°C	5sec ±1sec
Pb-Free devices.	260°C +0/-5°C	5sec ±1sec