

# Type CIS

## Surface Mount Slow Blow Chip Fuse

1206 size  
RoHS Compliant

CISDI005



### Electrical Characteristics (UL STD. 248-14)

Testing current	Blow Time	
	Minimum	Maximum
100%	4 hrs	N/A
200%	1 sec	120 sec
300%	0.1 sec	3 sec
800%	0.002 sec	0.05 sec

### Approvals



Safety Agency Approvals	Amp range / Volt @ I.R. ability
UL Recognized File No. E20624	750mA - 5A / 63V @ 50A AC / DC

### RoHS Compliant Product

RoHS Reflow Reference : JEDEC J-STD-020C (260°C, 40 sec max)

RoHS Wave Soldering Compatible : (260°C, 10 sec max)

### Environmental Specification

#### Shock Resistance

MIL-STD-202G, Method 213B, Test Condition I  
(100 G's peak for 6 milliseconds; Sawtooth Waveform)

#### Vibration Resistance

MIL-STD-202G, Method 201F (10-55 Hz, 0.06 inch, total excursion)

#### Salt Spray Resistance

MIL-STD-202G, Method 101E, Test condition B (48 hrs)

#### Insulation Resistance

MIL-STD-202G, Method 302, Test Condition A  
(After Opening) 10,000 ohms minimum

#### Solderability

MIL-STD-202G, Method 208H

#### Soldering Heat Resistance

MIL-STD-202G Method 210F, Test Condition C. Top Side  
(260°C, 20 sec)

MIL-STD-202G Method 210F, Test Condition D. Bottom Side  
(260°C, 10 sec)

#### Thermal Shock Resistance

MIL-STD-202G, Method 107G, Test Condition B  
(-65°C to +125°C)

#### Operating Temperature

-55°C to +125°C

Catalog Number	Ampere Rating	Typical Cold Resistance (ohm)	Volt-drop @100% In (Volt) max.	Melting I <sup>2</sup> T @10 In (A <sup>2</sup> Sec)	Maximum Power Dissipation (W)
CIS 750	750mA	0.420	0.442	0.037	0.40
CIS 1	1A	0.220	0.325	0.068	0.39
CIS 1.25	1.25A	0.215	0.363	0.11	0.54
CIS 1.5	1.5A	0.108	0.313	0.24	0.56
CIS 2	2A	0.098	0.250	0.44	0.60
CIS 2.5	2.5A	0.053	0.212	0.74	0.64
CIS 3	3A	0.040	0.189	1.11	0.68
CIS 3.5	3.5A	0.031	0.173	1.58	0.74
CIS 4	4A	0.026	0.165	2.00	0.79
CIS 5	5A	0.019	0.153	3.40	0.92

Consult manufacturer for other ratings

### Physical Specification

#### Materials

Ceramic Substrate / Printed Element

#### Marking

On fuse:

None

Label on reel:

"bel", "CIS", "Current Rating", "Voltage Rating", "Interrupting Rating",  
"Appropriate Safety Logos" and "RoHS" for RoHS Version

#### Packaging

5,000 fuses in 7 inches dia. reel, 8 mm wide tape, 4 mm pitch per EIA-481  
(equivalent IEC-286 part 3)

### Mechanical Dimensions

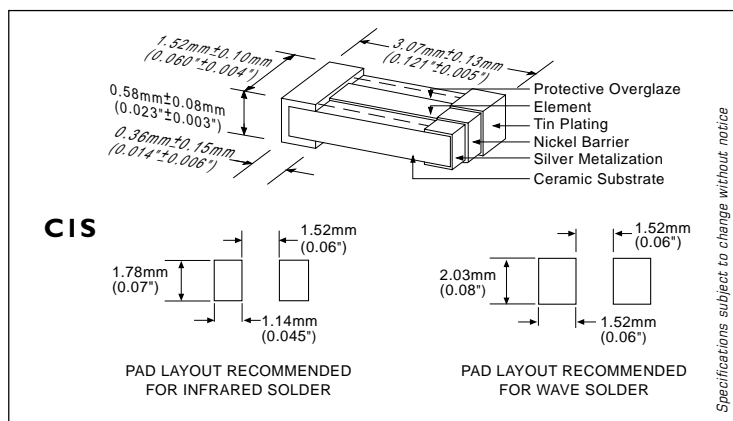

Specifications subject to change without notice

ORDERING INFORMATION SEE LAST 2 PAGES

**Type CIS**  
Surface Mount Slow Blow Chip Fuse

1206 size  
RoHS Compliant

CISC1004

**CIS - TIME CURRENT CHARACTERISTIC CURVE**

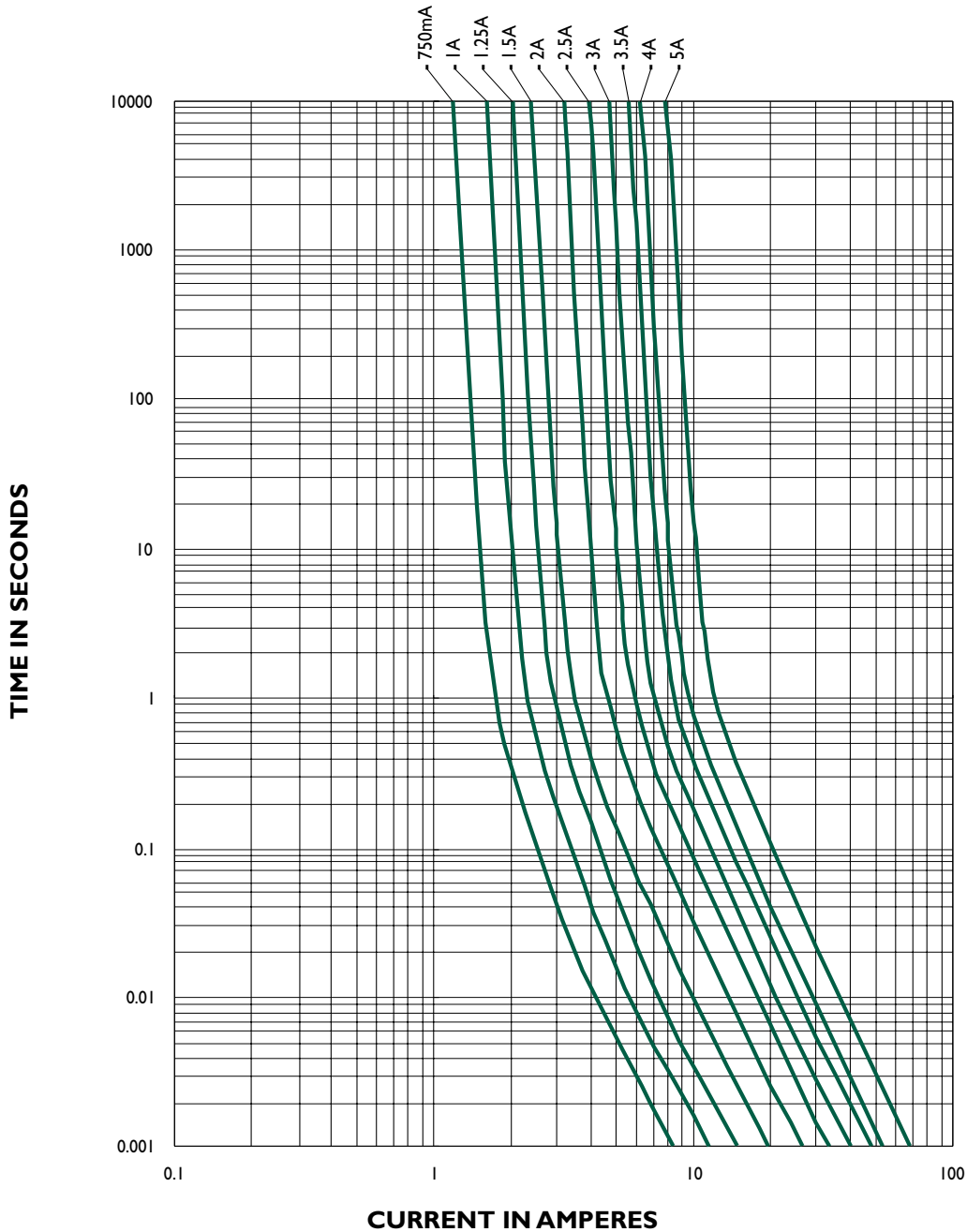

NOTE - see important information under "User Guide" on P.08

**Corporate Office**  
**Bel Fuse Inc.**  
206 Van Vorst Street, Jersey City, NJ 07302  
Tel: 201-432-0463  
Fax: 201-432-9542  
E-Mail: [belfuse@belfuse.com](mailto:belfuse@belfuse.com)  
Website: [www.belfuse.com](http://www.belfuse.com)

**Far East Office**  
**Bel Fuse Ltd.**  
8F/8 Luk Hop Street  
San Po Kong  
Kowloon, Hong Kong  
Tel: 852-2328-5515  
Fax: 852-2352-3706

**European Office**  
**Bel Fuse Europe Ltd.**  
Preston Technology Management Centre  
Marsh Lane, Preston PR1 8UD  
Lancashire, U.K  
Tel: 44-1772-556601  
Fax: 44-1772-888366