

Dual Channel Fixed Gain Differential DSL Line Driver

The ISL1532A is a dual channel differential amplifier designed for driving full rate ADSL2+ signals at very low power dissipation. The high drive capability of 450mA makes this driver ideal for DMT designs. It contains two pairs of wideband, high-voltage, current mode feedback amplifiers designed on Intersil's HS30 Bipolar SOI process for low power consumption in DSL systems. The amplifiers have an internal fixed gain, which helps eliminate both feedback and gain resistors reducing board size and cost.

These drivers achieve an MTPR distortion measurement of better than 70dB, while consuming typically 5mA per DSL channel of total supply current. This supply current can be set using a resistor on the I_{ADJ} pin. Two other pins (C₀ and C₁) can also be used to adjust supply current to one of four pre-set modes (full-I_S, 3/4-I_S, 1/2-I_S, and full power-down). The device is supplied in a thermally-enhanced 20 Ld HTSSOP and the small footprint (4x5mm) 24 Ld QFN packages. The ISL1532A is specified for operation over the full -40°C to +85°C temperature range.

The ISL1532A provides larger output swing at heavy loads, higher slew rate, and higher bandwidth while maintaining pin-to-pin drop-in compatibility with the EL1528. The ISL1532A integrates 50k pull-up resistors on C₀ and C₁ pins.

Pinouts

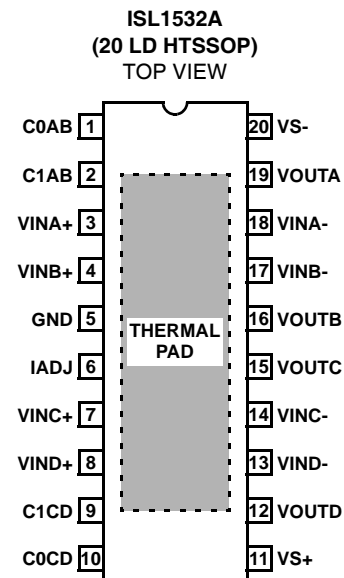
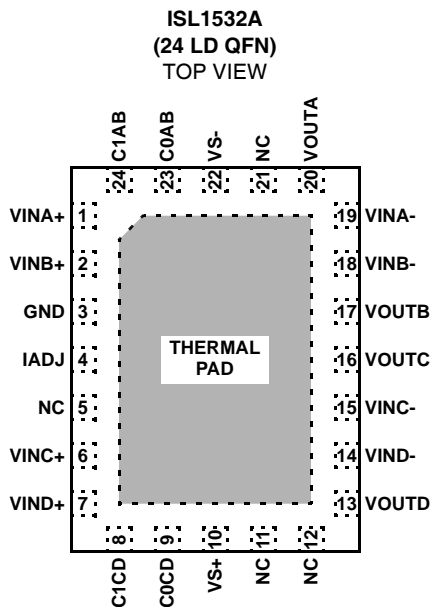

Features

- 450mA output drive capability
- 44.4V_{P-P} differential output drive into 100Ω
- ±5V to ±15V supply operation
- Internal fixed gain
- MTPR of -70dB
- Operates down to 2mA per amplifier supply current
- Current control pins
- Channel separation
 - 80dB @ 500kHz
 - 75dB @ 1MHz
- Direct pin-to-pin replacement for EL1528
- Pb-free plus anneal available (RoHS compliant)

Applications

- Dual port ADSL line drivers
- HDSL line drivers
- VDSL line driver

Get Full Datasheet

All Intersil U.S. products are manufactured, assembled and tested utilizing ISO9000 quality systems.
Intersil Corporation's quality certifications can be viewed at www.intersil.com/design/quality

Intersil products are sold by description only. Intersil Corporation reserves the right to make changes in circuit design, software and/or specifications at any time without notice. Accordingly, the reader is cautioned to verify that data sheets are current before placing orders. Information furnished by Intersil is believed to be accurate and reliable. However, no responsibility is assumed by Intersil or its subsidiaries for its use; nor for any infringements of patents or other rights of third parties which may result from its use. No license is granted by implication or otherwise under any patent or patent rights of Intersil or its subsidiaries.

For information regarding Intersil Corporation and its products, see www.intersil.com