

**Dual 10-bit Nonvolatile DAC
In-system Programmable Analog**

FEATURES

- Two 10-bit Nonvolatile DACs
 - INL ± 1 LSB
 - DNL: ± 1 LSB
- Programmable Configuration
- Programmable Power-on Reset Options
 - Recall Full Scale Value
 - Recall Zero Scale Value
 - Recall Mid-Scale Value
 - Recall NV Register Value
- Tandem or Independent Operation of DACs
- Power-down mode (short V_{OUT} to gnd)

ISPa™

OVERVIEW

The SMP9210 is a serial input, voltage output, dual 10-bit digital to analog converter. It can operate from a single +2.7V to +5.5V supply. Internal precision buffers swing rail-to-rail with an input reference range from ground to the positive supply.

The SMP9210 integrates two 10-bit DACs and their associated circuits that include; an enhanced unity gain operational amplifier output, a 10-bit volatile data latch, a 10-bit nonvolatile data register and an industry standard 2-wire serial interface.

BLOCK DIAGRAM

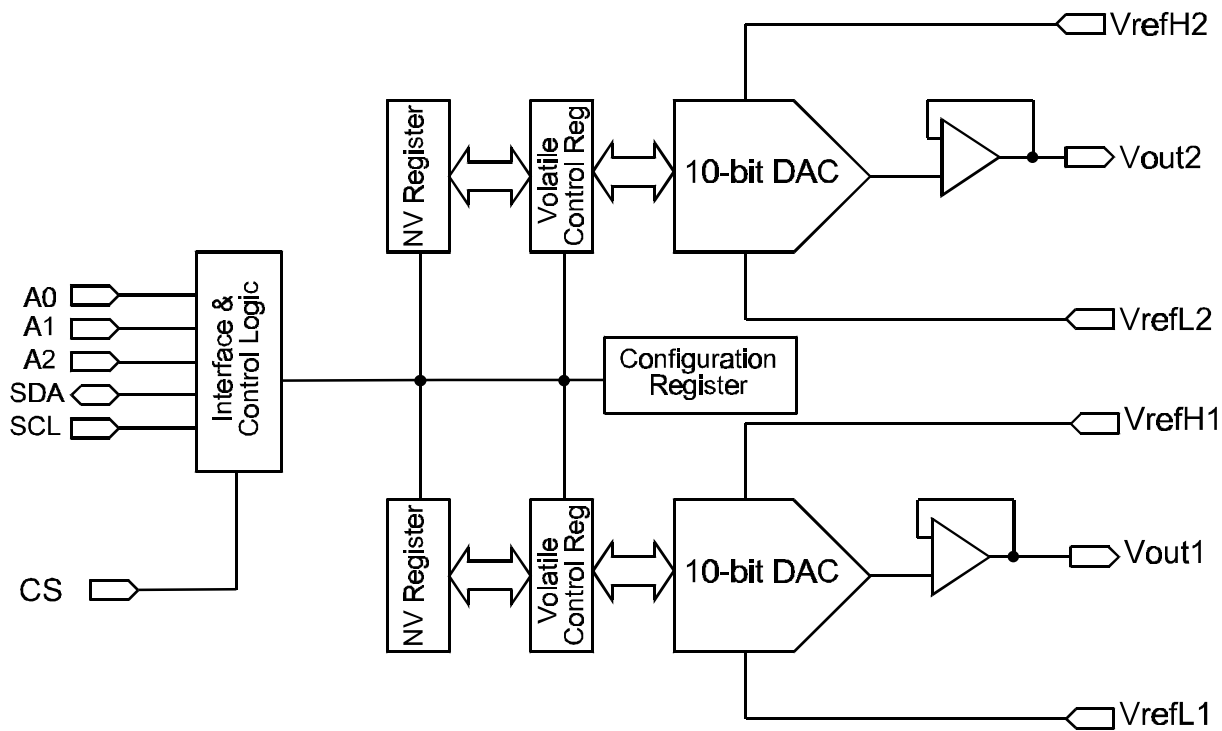

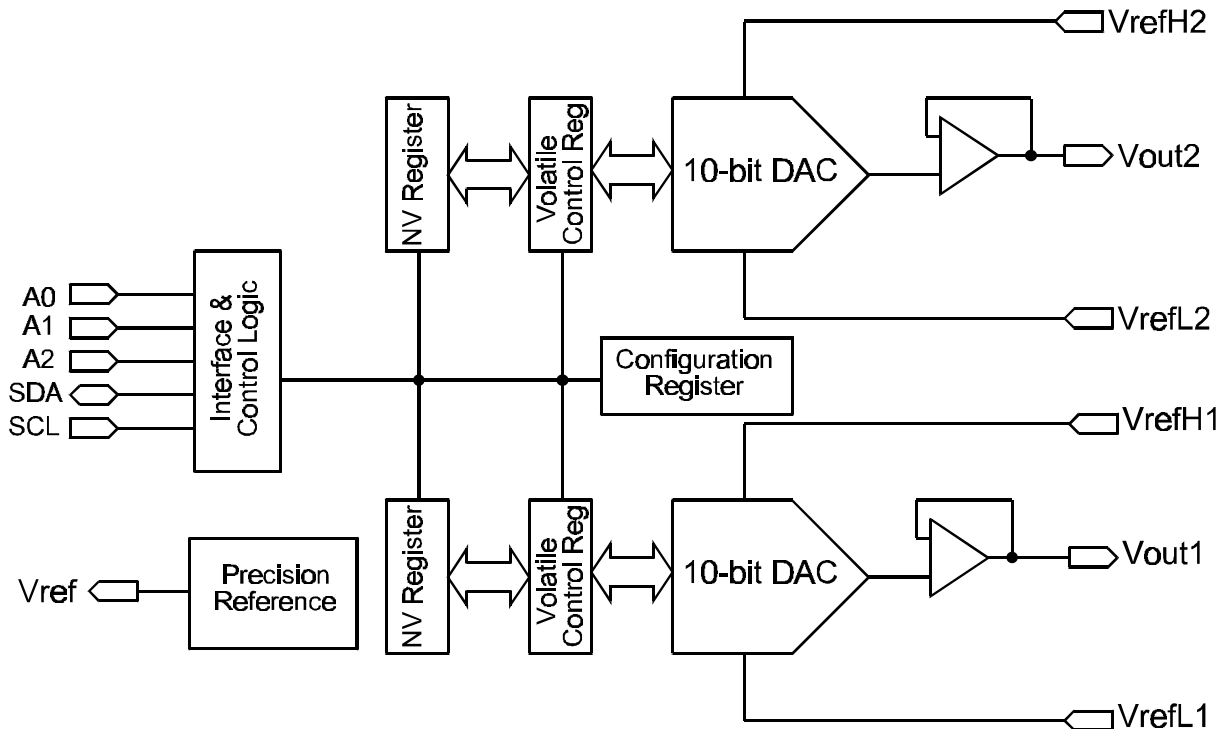
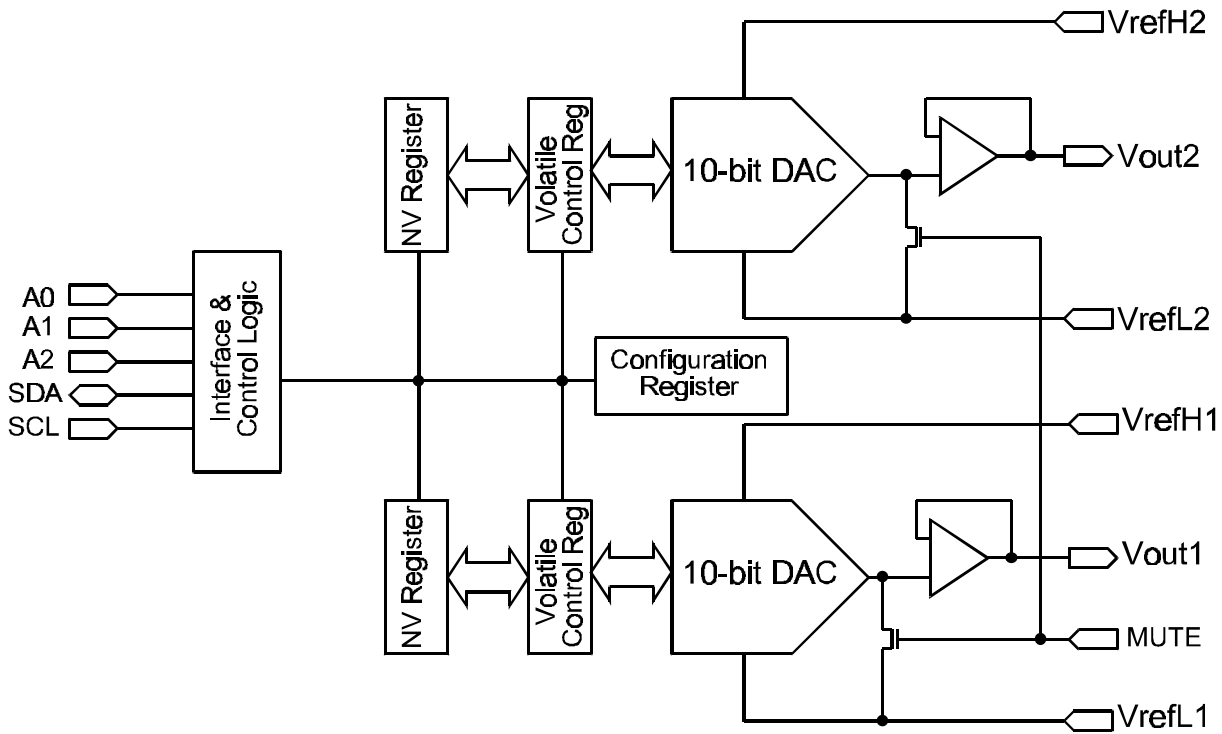

SMP9210

Signal	Pin	Function
A2	1	Address Pin A2
A1	2	Address Pin A1
A0	3	Address Pin A0
V _{REFH2}	4	DAC2 VREFH Input
V _{REFL2}	5	DAC2 VREFL Input
V _{OUT2}	6	DAC2 V _{OUT}
Gnd	7	Ground
CS	8	Chip Select
V _{OUT1}		DAC1 V _{OUT}
V _{REFL1}	10	DAC1 VREFL Input
SCL	11	Serial Clock Input
V _{REFH1}	12	DAC1 VREFH Input
V _{DD}	13	Supply Voltage
SDA	14	Bi-directional Serial Data

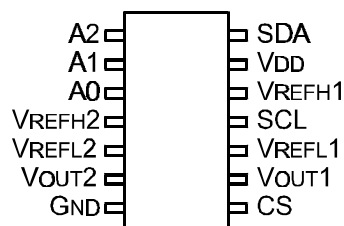
SMP9210

SMP9211

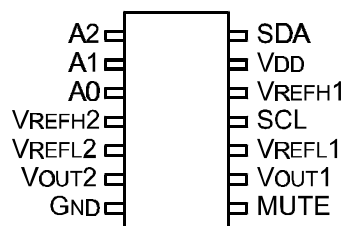
Signal	Pin	Function
A2	1	Address Pin A2
A1	2	Address Pin A1
A0	3	Address Pin A0
V _{REFH2}	4	DAC2 VREFH Input
V _{REFL2}	5	DAC2 VREFL Input
V _{OUT2}	6	DAC2 V _{OUT}
Gnd	7	Ground
MUTE	8	Mute Input
V _{OUT1}		DAC1 V _{OUT}
V _{REFL1}	10	DAC1 VREFL Input
SCL	11	Serial Clock Input
V _{REFH1}	12	DAC1 VREFH Input
V _{DD}	13	Supply Voltage
SDA	14	Bi-directional Serial Data

SMP9211

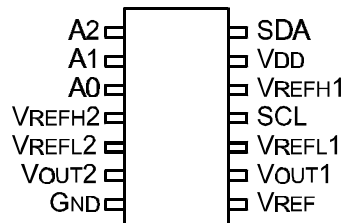
SMP9212

Signal	Pin	Function
A2	1	Address Pin A2
A1	2	Address Pin A1
A0	3	Address Pin A0
V _{REFH2}	4	DAC2 VREFH Input
V _{REFL2}	5	DAC2 VREFL Input
V _{OUT2}	6	DAC2 V _{OUT}
Gnd	7	Ground
V _{REF}	8	Reference Voltage Output
V _{OUT1}		DAC1 V _{OUT}
V _{REFL1}	10	DAC1 VREFL Input
SCL	11	Serial Clock Input
V _{REFH1}	12	DAC1 VREFH Input
V _{DD}	13	Supply Voltage
SDA	14	Bi-directional Serial Data

SMP9212

PIN DESCRIPTION

GND is the device ground pin.

V_{OUT} is the voltage output of the DACs. It is buffered by a unity-gain follower that can slew up to 1V/ s.

VREFL is the lower of the voltage reference inputs. VREFL must be equal to or greater than ground and less than VREFH.

VREFH is the higher of the voltage reference inputs. VREFH must be equal to or less than VCC and greater than VREFL.

A0, A1 and **A2** are the address inputs to the SMP9210 serial interface logic. Biasing the address inputs will determine the device's bus address that is contained within the serial data stream when communication over the serial bus.

SCL is the serial interface clock. It is used to clock data into and out of the SMP9210. When writing to the device, data must remain stable while SCL is HIGH. When reading, data is clocked out of the SMP9210 on the falling edge of SCL.

SDA is a bi-directional pin used to transfer data into and out of the SMP9210.

Pin 8 is a multifunction pin and is in-system programmable by the customer or it can be configured by Summit prior to shipment. It can function as Chip Select input (V_{IH} = selected), a MUTE input (V_{IH} = mute) or as a Vref output (1.25V).

Device Operation

The SMP9210 has two, 10-bit, digital to analog converters that are comprised of a resistor network that converts 10-bit digital inputs into equivalent analog output voltages in proportion to the applied reference voltages. The voltage differential between the VREFL and VREFH inputs sets the full-scale output voltage for its respective DAC.

Each DAC has a 10-bit volatile register that holds the digital value decoded by the DAC into an analog voltage output. The register can be written directly via the serial interface, commanded to load the zero scale value, full scale value or mid-scale value or recall a preset value stored in a nonvolatile register.

Each DAC has a 10-bit nonvolatile register that can hold a 'set-and-forget' value that can be recalled whenever the device is powered-on.

The SMP9210 also has a nonvolatile configuration register that is accessible over the 2-wire bus. The configuration register is used to

select the device type identifier, the function of pin 8 and the DAC power-on state.

Accessing the DACs

The SMP9210 uses the industry standard 2-wire serial protocol. The bus is designed for two-way, two-line serial communication between different integrated circuits. The two lines are the SCL (serial clock) and SDA (serial data) and both lines must be tied to the positive supply through a pull-up resistor.. The protocol defines devices as being either masters or slaves, the SMP9210 will always be a slave in that it does not initiate any communications or provide a clock output.

Data transfers are initiated when a master issues a 'start' condition, which is a high to low transition on SDA while SCL is high. The start is immediately followed by an eight bit transmission: bits 7:1 comprise the device type identifier and bus device bus address; bit 0 is the read/write bit indicating the action to follow. If the intended device receives the byte and recognizes its address it will return an acknowledge during the 9th clock cycle. Some data transfers will be concluded with a 'stop' condition, which is a low to high transition on SDA while SCL is high. Note: a stop condition must be performed for all nonvolatile write operations.

Addressing Convention

S									
T									
A	0	1	0	1	A	A	A	R/	A
R					2	1	0	W	C
T									K

The DAC device type identifier default is 0101[b]. In order to accommodate more than eight devices on a single bus, the device type identifier can be modified by the end user by writing to the configuration registers.

The command structure is illustrated in Table 1. Of special note is the ability to write individually to the two DACs or write to them in tandem. The first three commands are three bytes in length and can either be volatile or nonvolatile.

The 'Zero' commands load all zeroes into the DAC registers forcing the V_{OUT} to VREFL. The 3F commands load all ones into the DAC registers, forcing V_{OUT} to VREFH. The Recall commands, write the nonvolatile register value into the DAC registers. The PD commands connect V_{OUT} to GND. These four commands are all two bytes; the device

Table 1. Command Structure.

MSB								LSB		Command	Function
7	6	5	4	3	2	1	0				
1	0	0	1	dc	dc	D9	D8	Write DAC1	Write 10-bit value to DAC1		
1	0	1	0	dc	dc	D9	D8	Write DAC2	Write 10-bit value to DAC2		
1	0	1	1	dc	dc	D9	D8	Write Both DACS	Write the same 10-bit value to DAC1 and DAC2		
1	1	0	1	1	1	1	0	ZeroDAC1	Set DAC1 to Zero Scale (V_{REFL})		
1	1	0	1	1	1	0	1	ZeroDAC2	Set DAC2 to Zero Scale (V_{REFL})		
1	1	0	1	1	1	1	1	ZeroBOTH	Set DAC1 & DAC2 to Zero Scale (V_{REFL})		
1	1	1	0	1	1	1	0	3FDAC1	Set DAC1 to Full Scale (V_{REFL})		
1	1	1	0	1	1	0	1	3FDAC2	Set DAC2 to Full Scale (V_{REFL})		
1	1	1	0	1	1	1	1	3FBOTH	Set DAC1 & DAC2 to Full Scale (V_{REFL})		
1	1	1	1	dc	dc	1	0	RecallDAC1	Recall E^2 to DAC1		
1	1	1	1	dc	dc	0	1	RecallDAC2	Recall E^2 to DAC2		
1	1	1	1	dc	dc	1	1	RecallBoth	Recall E^2 to Both DACs		
1	0	0	0	dc	dc	1	0	PDDAC1	Power Down DAC1 (V_{OUT} to GND)		
1	0	0	0	dc	dc	0	1	PDDAC2	Power Down DAC2 (V_{OUT} to GND)		
1	0	0	0	dc	dc	1	1	PDBOTH	Power Down Both DACs (V_{OUT} to GND)		

*dc = don't care

type/address byte followed by the command byte. They will be enforced with or without a stop being issued and the new register value is never stored in the nonvolatile register.

Writing a value to a DAC can either be a write to the DAC register only or a combined write to both the DAC Register and its nonvolatile register. They are identical with the one exception being the register write does not entail issuing a stop condition; whereas, the nonvolatile write operation is concluded with a stop.

The sequence is to issue a start, followed by the device type and bus address, with the read/write bit

set to zero. The SMP9210 will respond with an acknowledge and the master will then issue the command and follow-on data. In the example below the write is to DAC1, where the command = 1001[b]; the dc bits are don't care, D9 and D8 are the MSBs of the DAC value being written. The SMP9210 will then respond with an acknowledge followed by the master writing the last eight bits. In the first example shown, no stop is generated after the SMP9210 acknowledge; therefore, the write is only to the register. In the second example the SMP9210 acknowledge is followed by a stop; therefore, the data is written to both the DAC register and to the nonvolatile register.

Writing to DACs Data Sequence (Volatile Write)

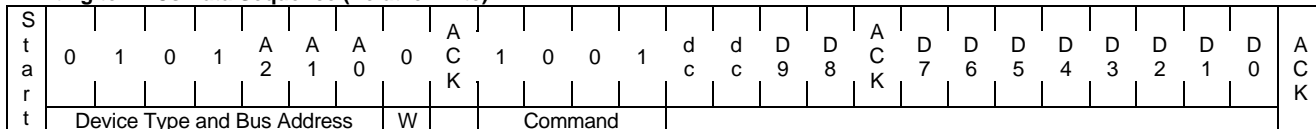

Writing to DACs Data Sequence (Nonvolatile Write)

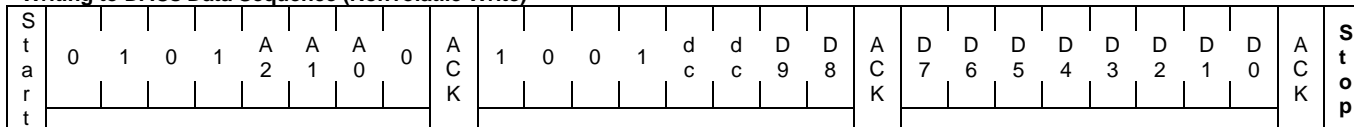

Command Sequence (example command shown 3FDAC1)

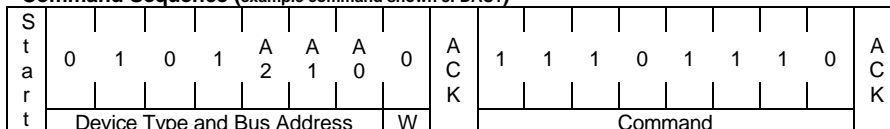

The third example illustrates the data sequence for a two-byte command.

Special Configurations

The SMP9210 can be configured by the end user or by Summit prior to shipment. There is one configuration register and it is accessed through the serial interface using 1001[b] as the device type address. The register is shown below.

MSB				LSB				
7	6	5	4	3	2	1	0	
A	A	A	A	L o r z	P O R 1	P O R 0	L O C K	
x	x	x	x	x	x	x	0	Config Register Accessible
x	x	x	x	x	x	x	1	Config Register Locked
x	x	x	x	x	0	0		Power-on Recall all 0's
x	x	x	x	x	0	1		Power-on Recall all 1's
x	x	x	x	x	1	0		Power-on Recall Mid Scale
x	x	x	x	x	1	1		Power-on Recall NV-Register
x	x	x	x	0				$V_{OUT} = \text{Low Z on Power-Down}$
x	x	x	x	1				$V_{OUT} = \text{High Z on Power-Down}$
A	A	A	A					Programmable DAC Device Type Address

Bit 0 - When bit 0 is written as a 1 the configuration register will be locked and it will become inaccessible for reading and writing.

Bits 2:1 are use to select the power-on recall value to be loaded into the DAC registers.

Bit 3 selects the power down option for the V_{OUT} pins.

Bits 7:4 can be used to program unique DAC device type identifiers. When the default 0101 is used the number of SMP9210's allowed on a single bus is limited to eight. This can be expanded infinitely if the CS input is also used. The only drawback is the decoding or use of port pins to drive the CS inputs. If we assume no other devices on the bus and that each DAC device type address is utilized, then the end user can effectively have 256 individually addressable devices on a single bus. Now, combining this capability with the CS pin a microC can enable blocks of 256 SMP9210's vs blocks of 8.

DAC Analog Characteristics

Symbol	Parameter	Condition	Min.	Type.	Max	Units
Static Performance						
N	Resolution		10			Bits
INL	Relative Accuracy		-1.0	+/-0.5	+1.0	LSB
DNL	Differential Nonlinearity	GUARANTEED MONOTONIC	-1	+/-0.5	+1	LSB
VZSE	Zero Scale Error	Data = 000H	0		5	mV
VFS	Full Scale Voltage	Data = 3FFH			VrefH	V
TCV	Full-Scale Tempco			=/-15		ppm
MATCHING PERFORMANCE						
	Linearity Matching Error			+/-1		LSB
ANALOG OUTPUT						
IOUT	Output Current	Data = 200H, ΔV_{out} ,3LSB			+/-5	mA
LDREG	Load Regulation @ Halfscale	RL = 1K Ω to infinity, Data = 200H		1	3	LSB
CL	Capacitive Load	No Oscillation		500		pF
Dynamic characteristics						
BW_10K	Bandwidth -3dB	R = 10K Ω		100		kHZ
THD	Total Harmonic Distortion	VA=1Vrms ,f=1KHz,		0.08		%
	Channel to Channel Isolation	f = 1KHz VIN = 100mV p-p on VrefH		-60		dB
	Digital Cross Talk			-60		dB
Reference Voltages						
VrefH		VrefH > VrefL	Gnd+?		VCC	V
VrefL		VrefL < VrefH	Gnd		VCC-?	V
Power						
ISY	VDD Supply Current	VDD = +5V, excludes Iref			100	μ A
Iref	Reference Voltage Current				100	μ A
VSYS	Supply Voltage		2.7		5.5	V

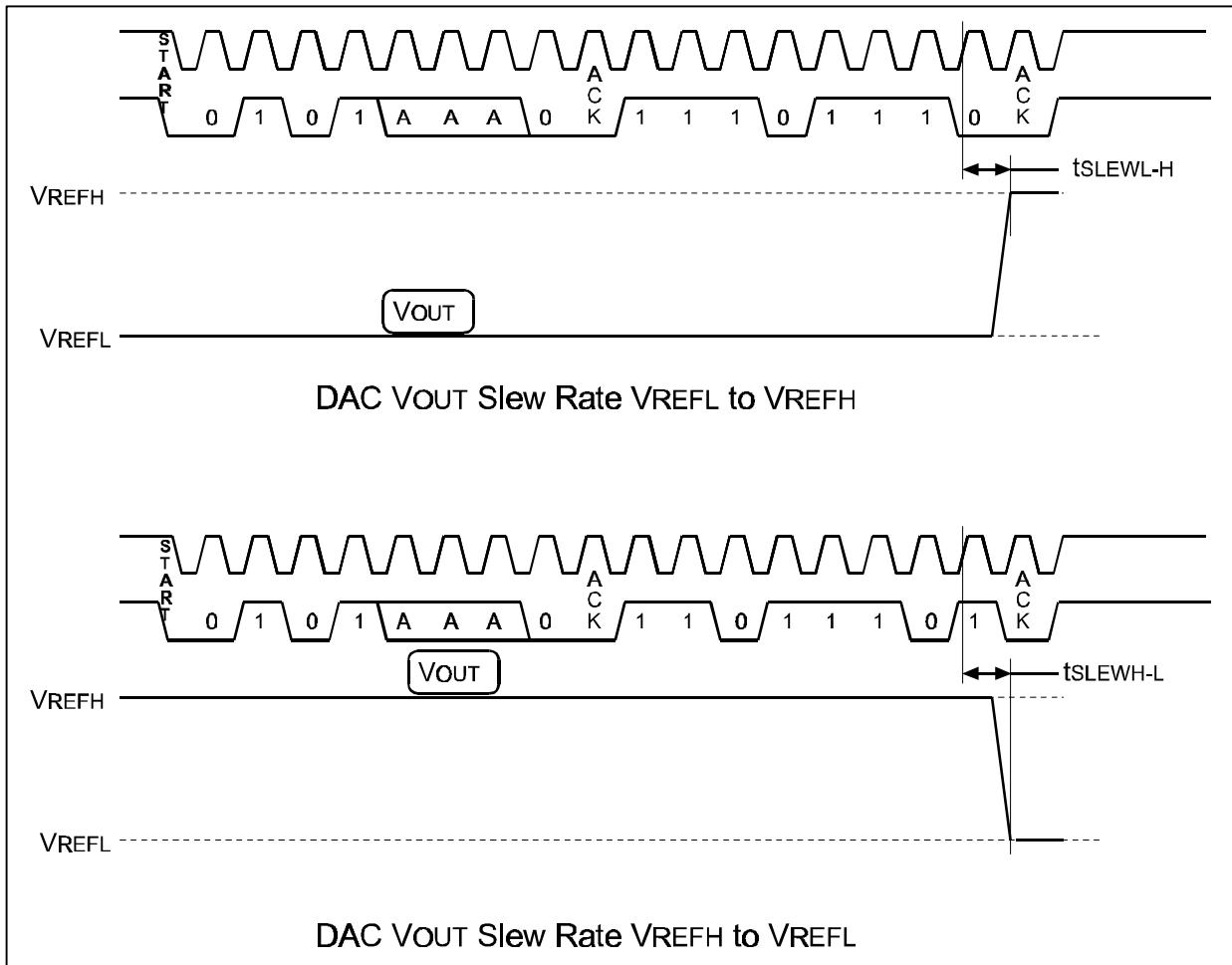

Symbol	Parameter	Condition	Min.	Typ.	Max.	Units
I _{DD}	Power Supply Current	NV Write				mA
			V _{DD} = 5.5V			
			V _{DD} = 2.7V			
	Standby or Quiescent	Excluding Current				μA
		Through DACs	V _{DD} = 5.5V			
			V _{DD} = 2.7V			
	Power Down	Total Current				μA
		Including DAC	V _{DD} = 5.5V			
			V _{DD} = 2.7V			
V _{DD}	Supply Voltage		2.7		5.5	V
V _{IH}	SDA, SCL				0.7xV _{DD}	V
V _{IL}	SDA, SCL				0.3xV _{DD}	V
V _{OL}	SDA	I _{OL} = 3mA			0.4	V
I _{LI}	Input Leakage	V _{IN} = 0 to V _{DD}			10	mA
I _{LO}	Output Leakage	V _{OUT} = 0 to V _{DD}				
W _{END}	Write Endurance	Number of NV Store Operations	1x10 ⁶			NVStores
t _{DR}	Data Retention	NVData Retention	100			Years

AC Operating Characteristics (Over Recommended Operating Conditions)

Symbol	Parameter	Conditions	2.7V to 5.5V		Units
			Min.	Max.	
fSCL	SCL Clock Frequency		0	100	KHz
tLOW	Clock Low Period		4.7		μs
tHIGH	Clock High Period		4.0		μs
tBUF	Bus Free Time	Before New Transmission	4.7		μs
tSU:STA	Start Condition Setup Time		4.7		μs
tHD:STA	Start Condition Hold Time		4.0		μs
tSU:STO	Stop Condition Setup Time		4.7		μs
tAA	Clock Edge to Valid Output	SCL low to Valid SDA (cycle n)	0.3	3.5	μs
tDH	Data Out Hold Time	SCL low (cycle n+1) to SDA change	0.3		μs
tR	SCL and SDA Rise Time			1000	ns
tF	SCL and SDA Fall Time			300	ns
tSU:DAT	Data In Setup Time		250		ns
tHD:DAT	Data In Hold Time		0		ns
TI	Noise Filter SCL & SDA	Noise Suppression		100	ns
tWR	Write Cycle Time			5	ms

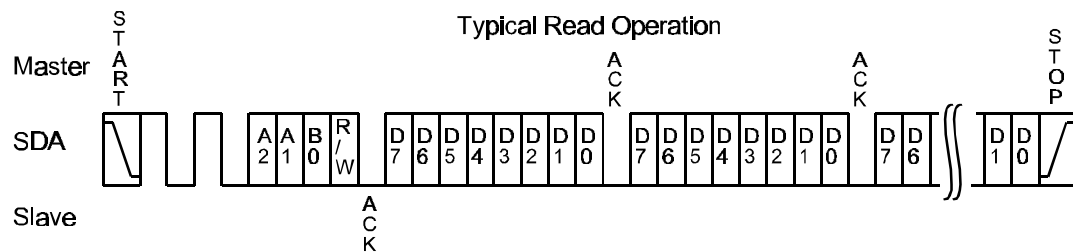
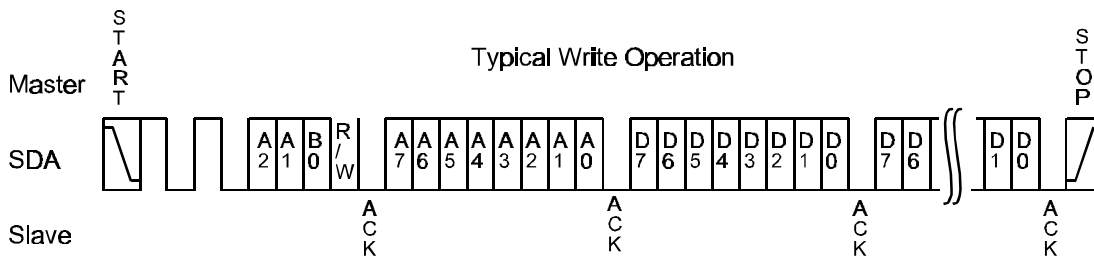
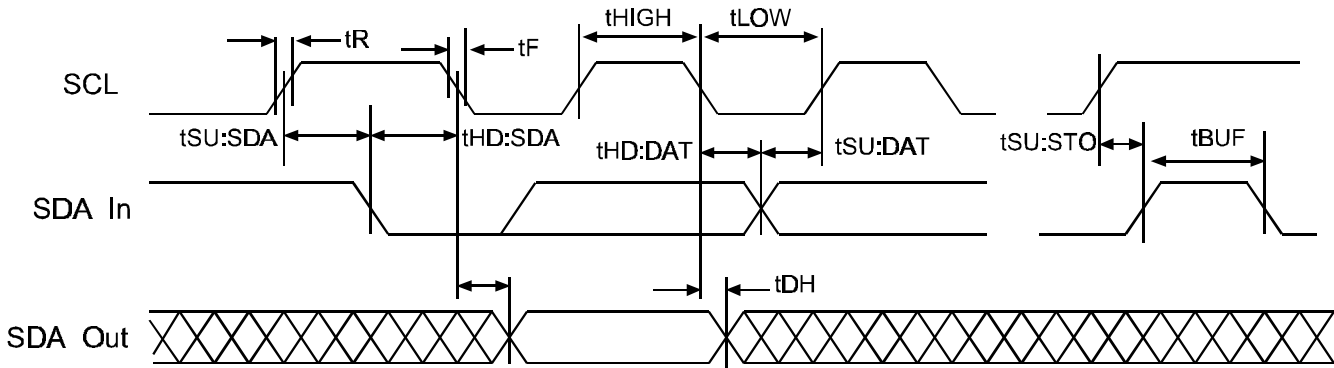

Ordering Information

SMP9210S	14 lead SOIC
SMP9211S	14 lead SOIC
SMP9212S	14 lead SOIC