

Thick film thermal printhead (8 dots / mm)

KD2003-DC10A

The KD2003-DC10A is a 24 V standard thick film thermal printhead with a printing speed up to 6 inches / s that has been developed mainly for label printer use.

●Applications

- High speed label printer
- High speed bar code printer
- High speed ticket printer
- Various high speed terminal printers

●Features

- 1) Newly developed thick-film fast response thermal element is employed for this series and 6 inches / s or 150 mm / s is possible without thermal history control. It is possible to print 10 inches / s or 250 mm / s if external thermal history control is used.
- 2) 150km life realized by attributing durable new protection film.
- 3) New partial glaze construction makes it compatible with the thermal transfer application.

●External dimensions (Unit : mm)

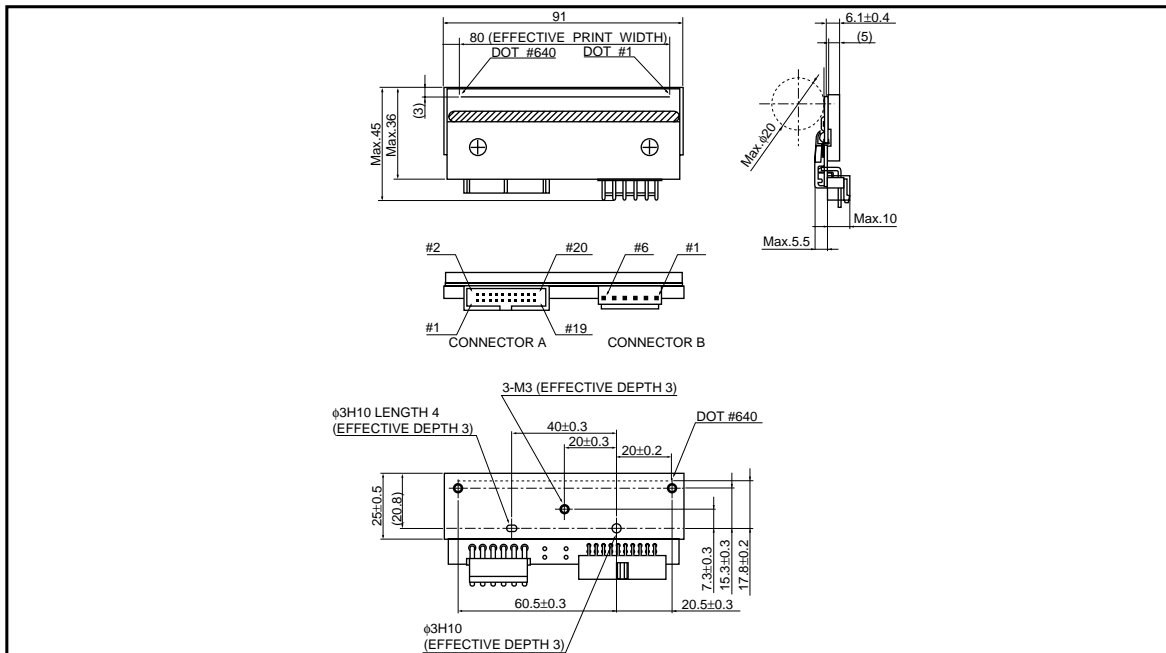

Printheads

●Equivalent circuit

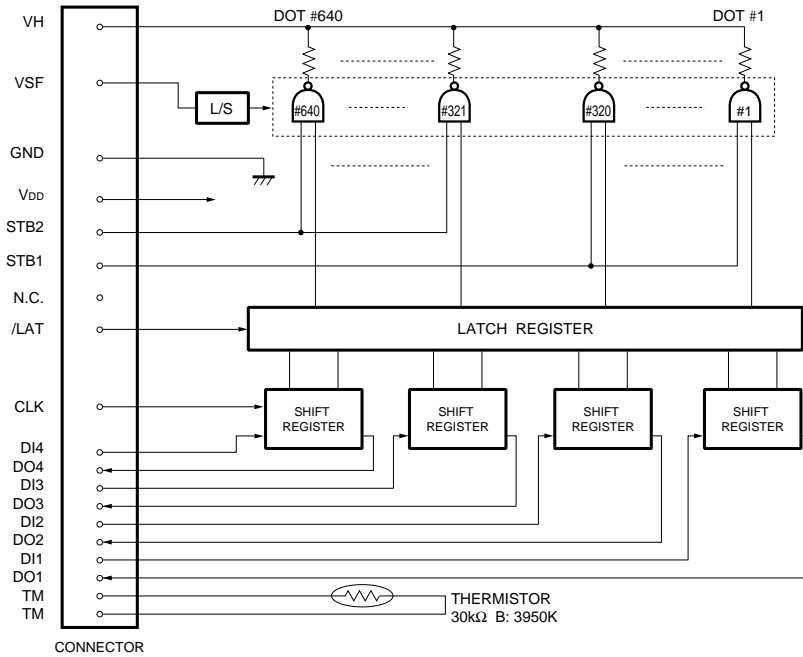

VSF : Usually VSF and VH are connected.
When measuring R value of Heat-element , VSF and VH should be separated.

DI No.	DOT No.	STB No.	DOT No.
DI1	1 to 192	STB1	1 to 320
DI2	193 to 320	STB2	321 to 640
DI3	321 to 512		
DI4	513 to 640		

Fig. 1

●Pin assignments

CONNECTOR A			
No.	Circuit	No.	Circuit
1	GND	11	TM
2	VSF	12	TM
3	GND	13	DI3
4	V _{DD}	14	DO3
5	STB2	15	DI2
6	CLK	16	DO2
7	DI4	17	N.C.
8	DO4	18	STB1
9	N.C.	19	DI1
10	$\overline{\text{LAT}}$	20	DO1

CONNECTOR B	
No.	Circuit
1	VH
2	VH
3	VH
4	GND
5	GND
6	GND

Printheads

●Timing chart

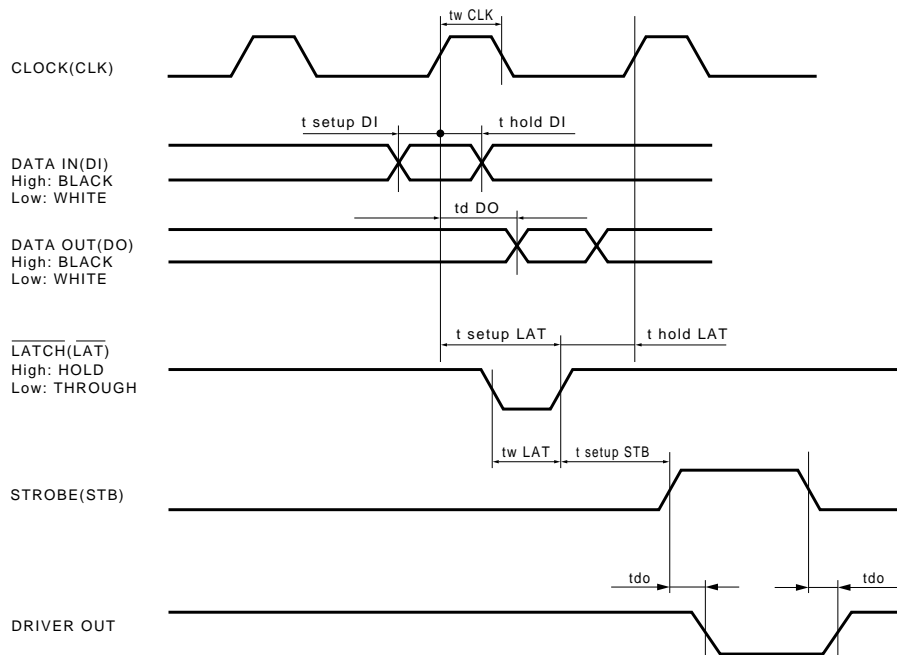

Fig.2

●Characteristics

Parameter	Symbol	Typical	Unit
Effective printing width	-	80	mm
Dot pitch	-	0.125	mm
Total dot number	-	640	dots
Average resistance value	Rave	650	Ω
Applied voltage	V _H	24	V
Applied power	P _o	0.80	W / dot
Print cycle	SLT	0.82	ms
Maximum number of dots energized simultaneously	-	640	dots
Maximum clock frequency	-	12	MHz
Maximum roller diameter	-	ϕ 20.0	mm
Running life / pulse life	-	150 / (1×10 ⁸)	km / pulses
Operating temperature	-	5 to 45	°C

Notes

- No technical content pages of this document may be reproduced in any form or transmitted by any means without prior permission of ROHM CO.,LTD.
- The contents described herein are subject to change without notice. The specifications for the product described in this document are for reference only. Upon actual use, therefore, please request that specifications to be separately delivered.
- Application circuit diagrams and circuit constants contained herein are shown as examples of standard use and operation. Please pay careful attention to the peripheral conditions when designing circuits and deciding upon circuit constants in the set.
- Any data, including, but not limited to application circuit diagrams information, described herein are intended only as illustrations of such devices and not as the specifications for such devices. ROHM CO.,LTD. disclaims any warranty that any use of such devices shall be free from infringement of any third party's intellectual property rights or other proprietary rights, and further, assumes no liability of whatsoever nature in the event of any such infringement, or arising from or connected with or related to the use of such devices.
- Upon the sale of any such devices, other than for buyer's right to use such devices itself, resell or otherwise dispose of the same, no express or implied right or license to practice or commercially exploit any intellectual property rights or other proprietary rights owned or controlled by
- ROHM CO., LTD. is granted to any such buyer.
- Products listed in this document are no antiradiation design.

The products listed in this document are designed to be used with ordinary electronic equipment or devices (such as audio visual equipment, office-automation equipment, communications devices, electrical appliances and electronic toys).

Should you intend to use these products with equipment or devices which require an extremely high level of reliability and the malfunction of which would directly endanger human life (such as medical instruments, transportation equipment, aerospace machinery, nuclear-reactor controllers, fuel controllers and other safety devices), please be sure to consult with our sales representative in advance.

About Export Control Order in Japan

Products described herein are the objects of controlled goods in Annex 1 (Item 16) of Export Trade Control Order in Japan.

In case of export from Japan, please confirm if it applies to "objective" criteria or an "informed" (by MITI clause) on the basis of "catch all controls for Non-Proliferation of Weapons of Mass Destruction.