



P1596

LINEAR INTEGRATED CIRCUIT

150KHZ, 1.5A PWM BUCK DC/DC CONVERTER

DESCRIPTION

The UTC P1596 series is a step-down switching regulator able to provide 1.5A output current. The available output voltages are 2.5V, 3.3V, 5V and an adjustable output version.

FEATURES

- *Output load current: 1.5A
- *Adjustable version output voltage range, 1.23V ~ 18V±4%
- *150KHz ±15% fixed switching frequency
- *Voltage mode non-synchronous PWM control
- *Thermal-shutdown and current-limit protection
- *Operating voltage can be up to 22V
- *Low power standby mode
- *High efficiency
- *Internal current and thermal limit
- *Built-in switching transistor on chip

ORDERING INFORMATION

Order Number		Package	Packing
Normal	Lead Free Plating		
P1596-xx-G04-K	P1596L-xx-G04-K	SIP-4	Bulk
P1596-xx-TA5-T	P1596L-xx-TA5-T	TO-220-5	Tube
P1596-xx-TB5-T	P1596L-xx-TB5-T	TO-220B	Tube
P1596-xx-TN5-R	P1596L-xx-TN5-R	TO-252-5	Tape Reel
P1596-xx-TN5-T	P1596L-xx-TN5-T	TO-252-5	Tube
P1596-xx-TQ5-R	P1596L-xx-TQ5-R	TO-263-5	Tape Reel
P1596-xx-TQ5-T	P1596L-xx-TQ5-T	TO-263-5	Tube

Note: xx: Output Voltage, refer to Marking Information.

<p>P1596L-xx-G04-K</p> <p>(1)Packing Type (2)Package Type (3)Output Voltage Code (4)Lead Plating</p>	<p>(1) K: Bulk, R: Tape Reel, T:Tube (2) G04: SIP-4, TA5: TO-220-5, TB5: TO-220B, TN 5: TO-252-5, TQ5: TO-263-5 (3) xx: refer to Marking Information (4) L: Lead Free Plating, Blank: Pb/Sn</p>
--	---

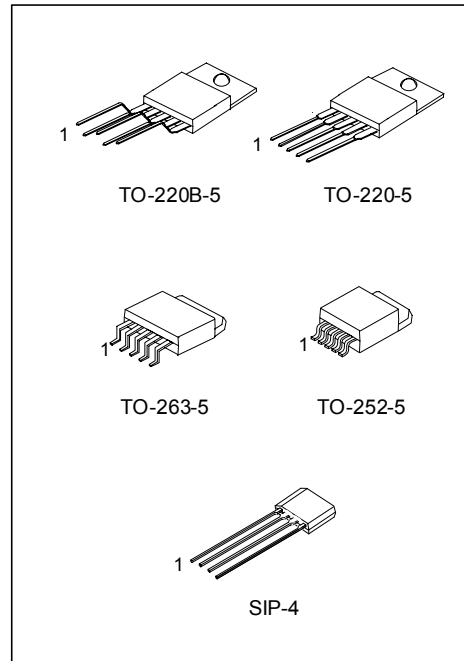

*Pb-free plating product number: P1596L

■ BLOCK DIAGRAM

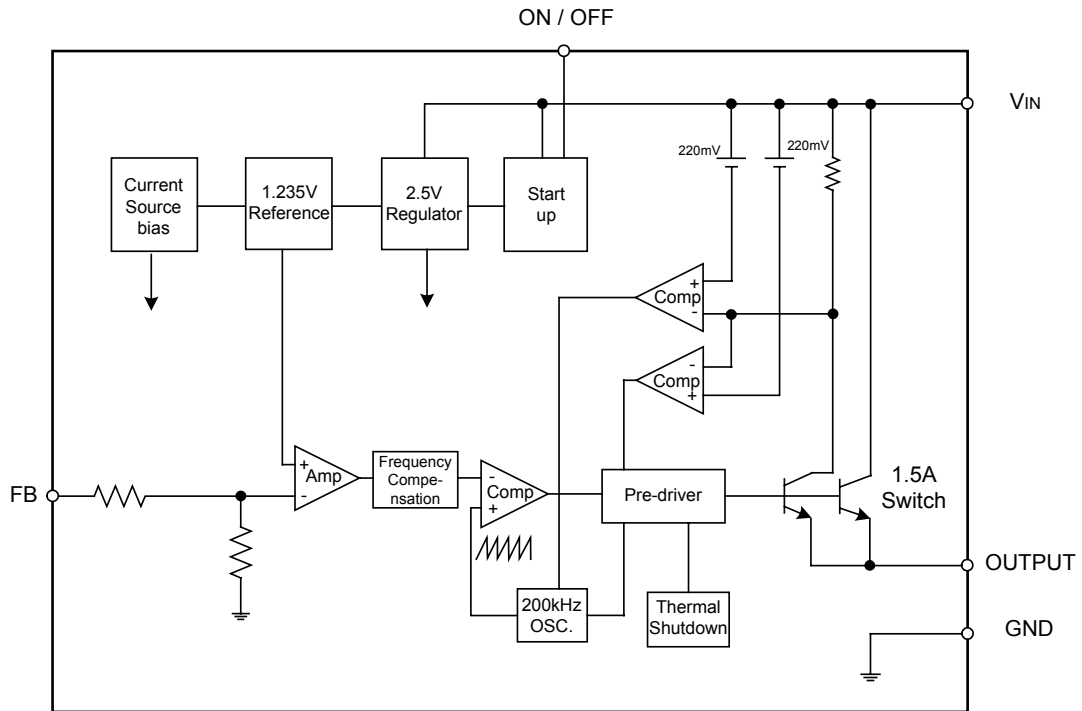

PIN DESCRIPTIONS

FOR 5-PIN	FOR 4-PIN	PIN NAME	DESCRIPTION
1	1	V _{IN}	Operating voltage input
2	2	Output	Switching output
3	4	GND	Circuit Ground
4	3	FB (Feedback)	Output voltage feedback control
5	-	SD (Shutdown)	ON/OFF shutdown

MARKING INFORMATION

PACKAGE	VOLTAGE CODE	MARKING
SIP-4	25:2.5V 33:3.3V 50:5.0V AD:ADJ	<p>UTC P1596</p> <p>Voltage Code →</p> <p>→ Lead Plating</p> <p>→ Date Code</p> <p>1 2 3 4</p>
TO-220-5 TO-220B TO-252-5 TO-263-5		<p>UTC P1596</p> <p>Voltage Code →</p> <p>→ Lead Plating</p> <p>→ Date Code</p> <p>1 2 3 4 5</p>

THERMAL DATA

PARAMETER		SYMBOL	RATINGS	UNIT
Thermal Resistance Junction to Case	SIP-4	θ_{JC}	30	°C/W
	TO-220B		3	
	TO-220-5		3	
	TO-252-5		8	
	TO-263-5		4	

■ ABSOLUTE MAXIMUM RATINGS

PARAMETER	SYMBOL	RATINGS	UNIT
Maximum Supply Voltage	V_{CC}	24	V
Operating Voltage	V_{OPR}	4.5 ~ 22	V
ON/OFF Pin Input Voltage	$V_{ON/OFF}$	-0.3 ~ +18	V
Feedback Pin Voltage	V_{FB}	-0.3 ~ +18	V
Output Voltage to Ground (Steady State)	V_{OUT}	-1	V
Power Dissipation	PD	Internally limited	W
Temperature Range	TOPR	-40 ~ +125	°C
Storage Temperature Range	TSTG	-65 ~ +150	°C

Note Absolute maximum ratings are those values beyond which the device which the device could be permanently damaged. Absolute maximum ratings are stress ratings only and functional device operation is not implied.

■ ELECTRICAL CHARACTERISTICS

($T_J=25^\circ\text{C}$, $V_{IN}=12\text{V}$ for 2.5V, 3.3V, 5V, ADJ and $V_{IN}=18\text{V}$ for the 12V, $I_{LOAD}=0.5\text{A}$, unless otherwise specified.)

PARAMETER	SYMBOL	TEST CONDITIONS	MIN	TYP	MAX	UNIT
Output Voltage	V_{OUT}	$3.8\text{V} \leq V_{IN} \leq 22\text{V}$, $0.2\text{A} \leq I_{LOAD} \leq 1.5\text{A}$	2.4	2.5	2.6	V
		$4.75\text{V} \leq V_{IN} \leq 22\text{V}$, $0.2\text{A} \leq I_{LOAD} \leq 1.5\text{A}$	3.168	3.3	3.432	V
		$7\text{V} \leq V_{IN} \leq 22\text{V}$, $0.2\text{A} \leq I_{LOAD} \leq 1.5\text{A}$	4.8	5.0	5.2	V
Efficiency	η	$V_{IN}=12\text{V}$, $I_{LOAD}=1.5\text{A}$		73		%
		$V_{IN}=12\text{V}$, $I_{LOAD}=1.5\text{A}$		73		%
		$V_{IN}=12\text{V}$, $I_{LOAD}=1.5\text{A}$		80		%
UTC P1596-ADJ						
Output Feedback	V_{FB}	$4.75\text{V} \leq V_{IN} \leq 22\text{V}$, $0.2\text{A} \leq I_{LOAD} \leq 1.5\text{A}$ V_{OUT} Programmed for 3V	1.193	1.23	1.267	V
Efficiency	η	$V_{IN}=12\text{V}$, $I_{LOAD}=1.5\text{A}$		78		%
ALL OUTPUT VOLTAGE						
Feedback Bias Current	I_{BIAS}	Adjustable Version Only, $V_{FB}=1.3\text{V}$		-10	-50	nA
Oscillator Frequency	f_{OSC}		127	150	173	KHz
Saturation Voltage	V_{SAT}	$I_{OUT}=1.5\text{A}$, No outside circuit $V_{FB}=0\text{V}$ force driver on		1.25	1.4	V
Duty Cycle	DC	$V_{FB}=0\text{V}$ force driver on		100		%
		$V_{FB}=12\text{V}$ force driver off		0		
Current Limit	I_{LIMIT}	Peak Current, No outside circuit $V_{FB}=0\text{V}$ force driver on	2			A
Output Leakage Current	I_{LEAK}	Output=0V, No outside circuit $V_{FB}=12\text{V}$ force driver off			-200	μA
		Output=-1V, $V_{IN}=12\text{V}$		-5		mA
Quiescent Current	I_Q	$V_{FB}=12\text{V}$ force driver off		5	10	mA
Standby Quiescent Current	I_{STBY}	ON/OFF Pin=5V, $V_{IN}=22\text{V}$		70	150	μA

■ TYPICAL APPLICATION

FOR ADJUSTABLE OUTPUT VOLTAGE VERSION

For 5 PIN:

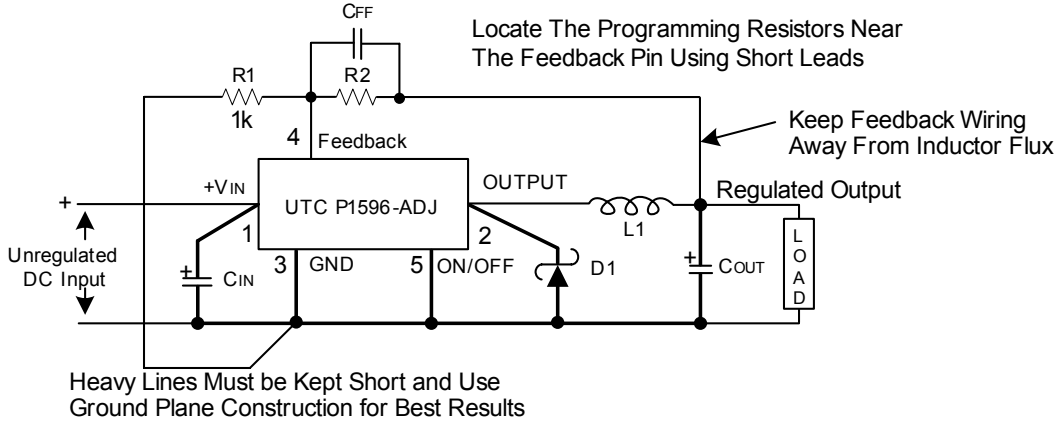

$$V_{OUT} \times (R_1 / (R_1 + R_2)) = V_{REF}$$

$$V_{OUT} = V_{REF} (1 + R_2 / R_1)$$

Where $V_{REF} = 1.23V$

$$R_2 = R_1 ((V_{OUT} / V_{REF}) - 1)$$

For 4 PIN:

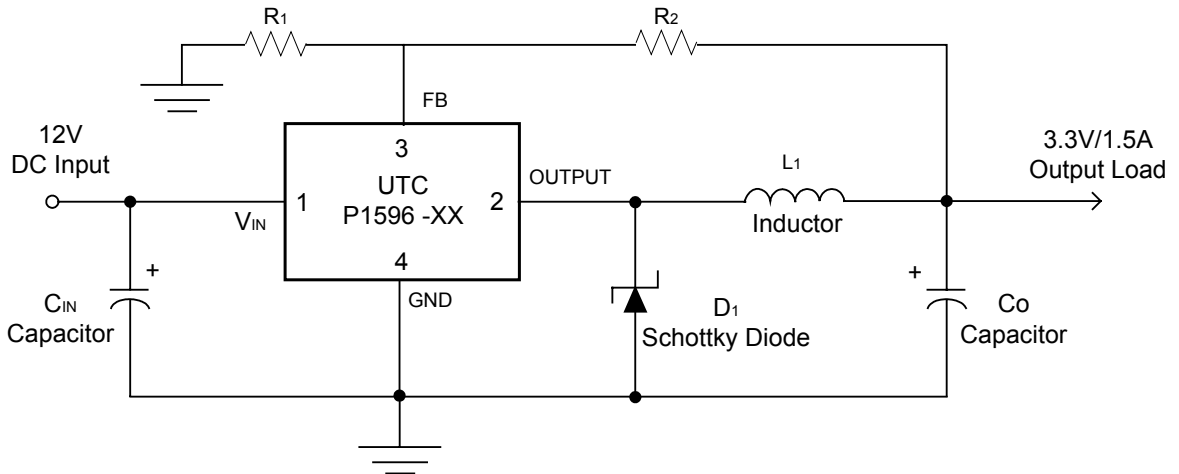

$$V_{OUT} = V_{FB} \times (1 + R_1 / R_2)$$

$V_{FB} = 1.23V$

$R_2 = 1K \sim 3K$

■ TYPICAL APPLICATION

FOR FIXED OUTPUT VOLTAGE VERSIONS

For 5 PIN:

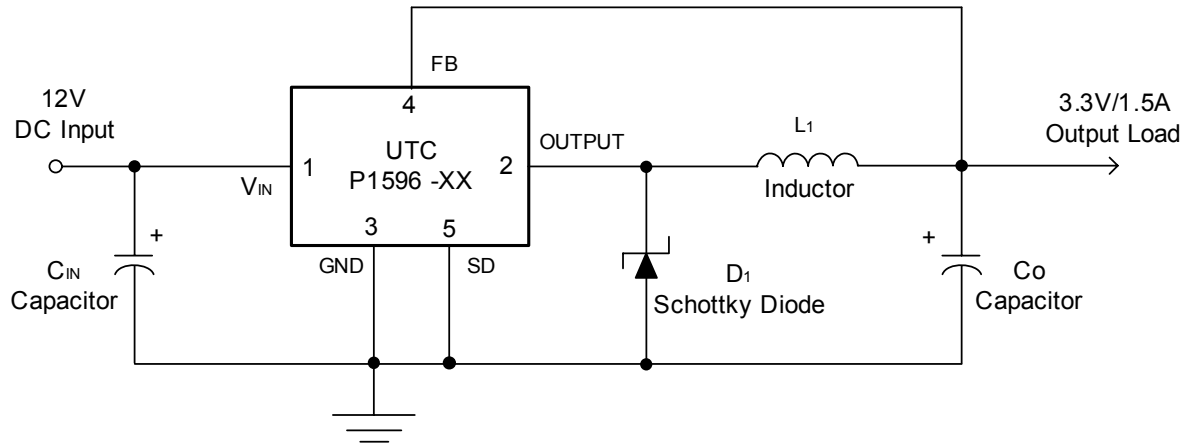

For 4 PIN:

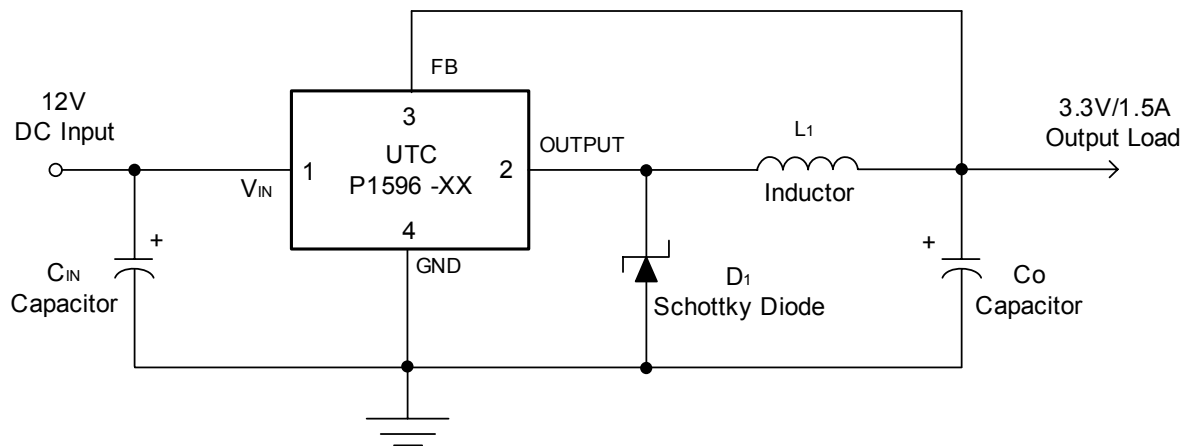

TYPICAL CHARACTERISTICS

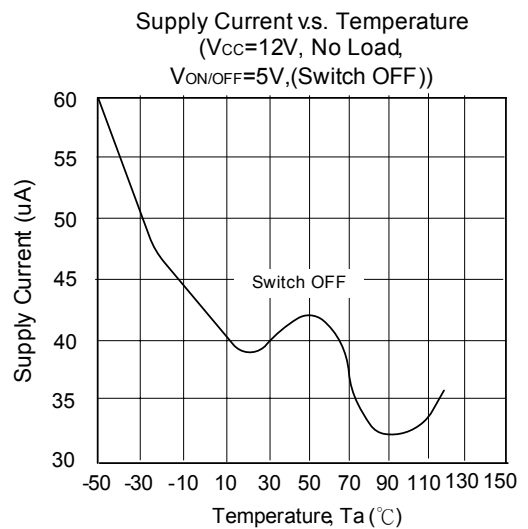
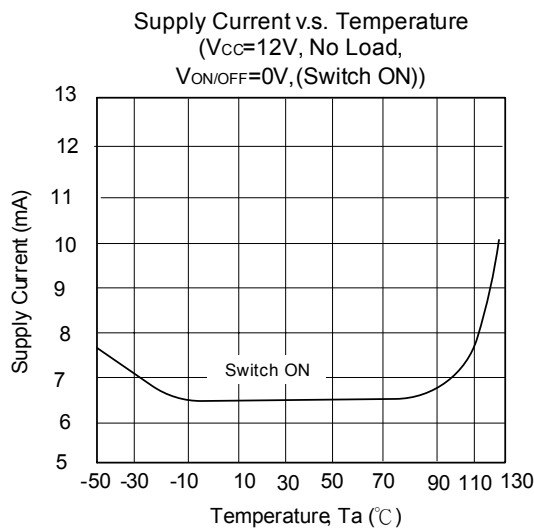
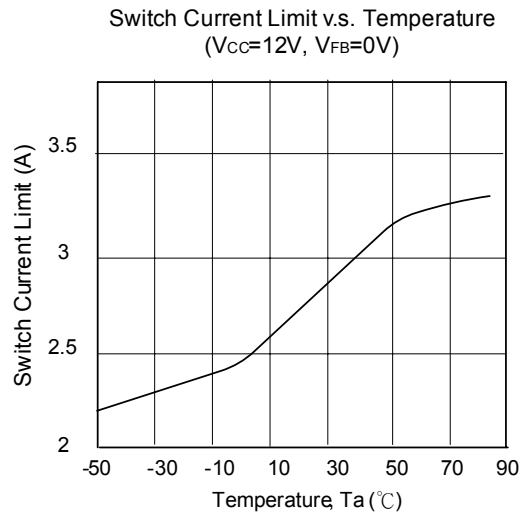
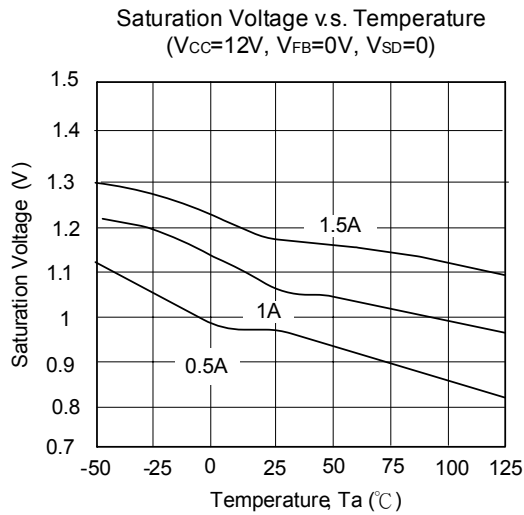
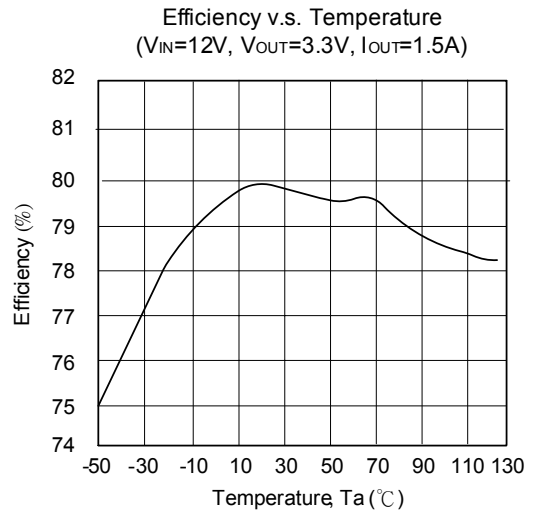
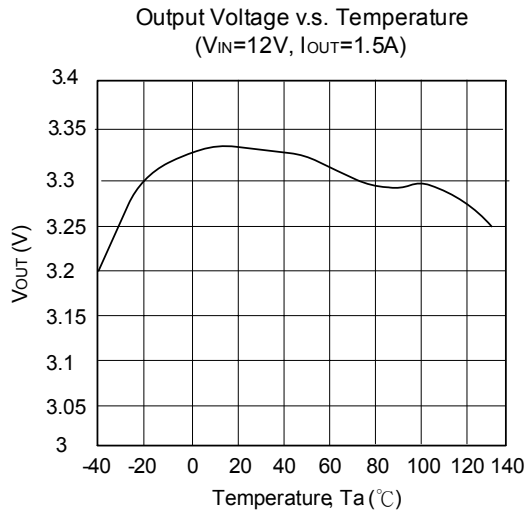

■ TYPICAL CHARACTERISTICS (Cont.)

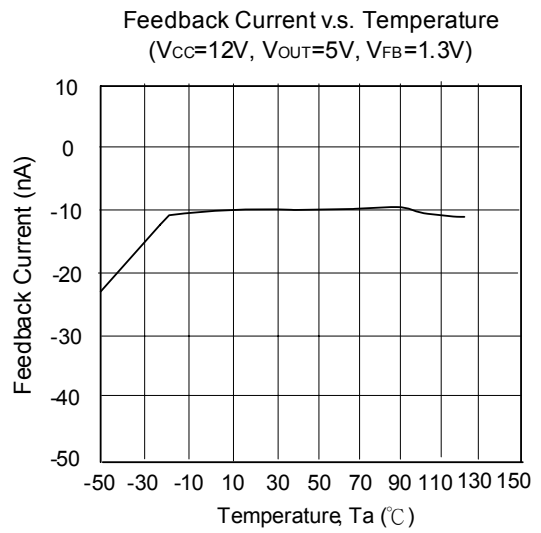
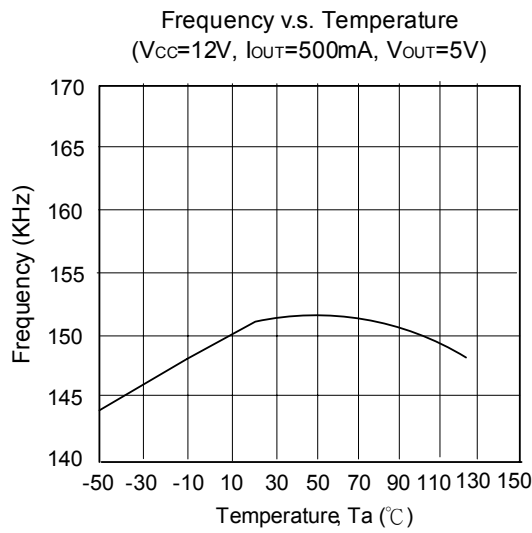

UTC assumes no responsibility for equipment failures that result from using products at values that exceed, even momentarily, rated values (such as maximum ratings, operating condition ranges, or other parameters) listed in products specifications of any and all UTC products described or contained herein. UTC products are not designed for use in life support appliances, devices or systems where malfunction of these products can be reasonably expected to result in personal injury. Reproduction in whole or in part is prohibited without the prior written consent of the copyright owner. The information presented in this document does not form part of any quotation or contract, is believed to be accurate and reliable and may be changed without notice.