

Model 3022

PC Board Mountable Accelerometer
 Millivolt Output
 Low Cost

- Vibration/Shock Monitoring
- Modal Analysis
- Motion Control
- Crash Testing
- Aerospace

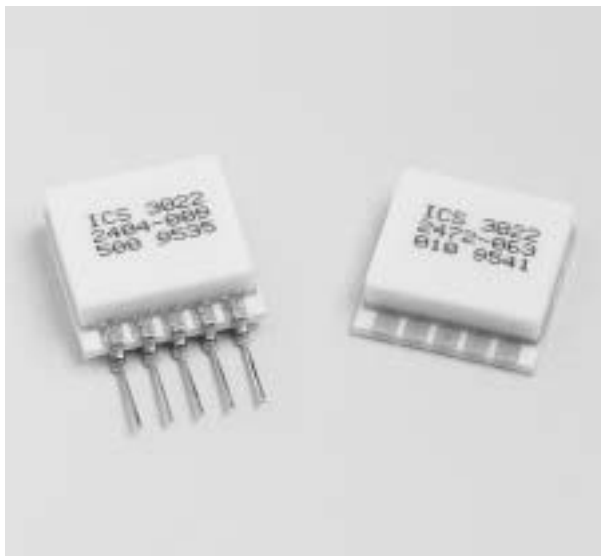

DESCRIPTION

The Model 3022 is a piezoresistive silicon accelerometer. The package is a ceramic substrate with a sealed ceramic cover. The ceramic provides an excellent bonding surface for the customer's application specific adhesive. Each accelerometer includes a detailed calibration sheet, which provides test data and resistor compensation values for each sensor.

The accelerometer consists of a micro machined silicon mass suspended by multiple beams from a silicon frame. Piezoresistors located in the beams change their resistance as the motion of the suspended mass changes the strain in the beams. Silicon caps on the top and bottom of the device are added to provide over-range stops. This design provides for a very low profile, high shock resistance, durability and built-in damping over a wide usable bandwidth. Each sensor is individually serialized.

For an accelerometer with a mounting bracket designed to bolt the sensor to a mounting location, see the Model 3028. Please refer to the Models 3052 and 3058 for accelerometers with integral temperature compensation.

FEATURES

- Designed for Adhesive Mounting
- $\pm 0.5\%$ Non-linearity (typical)
- $\pm 1.0\%$ Temperature Performance (with comp resistors-typical)
- DC Response
- Built-in Damping
- Built-in Over-range Stops
- Low Power
- Pins or No Pins

STANDARD RANGES

Range	g	Range	g
± 2	•	± 50	•
± 5	•	± 100	•
± 10	•	± 200	•
± 20	•	± 500	•

Internet: www.msiusa.com
 Tel: 1-757-766-1500
 North America Toll Free: 1-800-745-8008
 Fax: 1-757-766-4297

CALIBRATION DATA

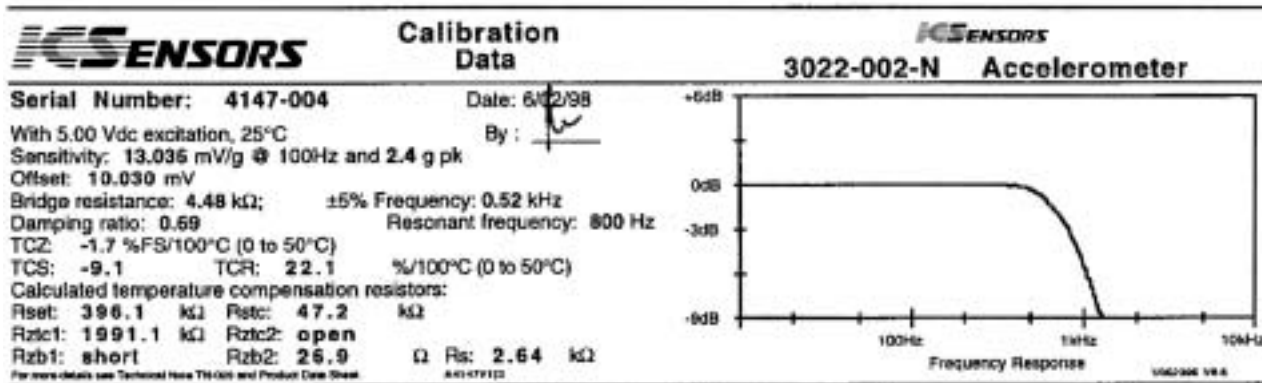

Figure 1. Calibration Data Sheet

A calibration data sheet similar to the sample shown above is included with each unit. The calibration sheet provides the measured test and calibration data for the sensor. In addition to the test data, the values of calibration and temperature compensation resistors are also included.

SIGNAL CONDITIONING

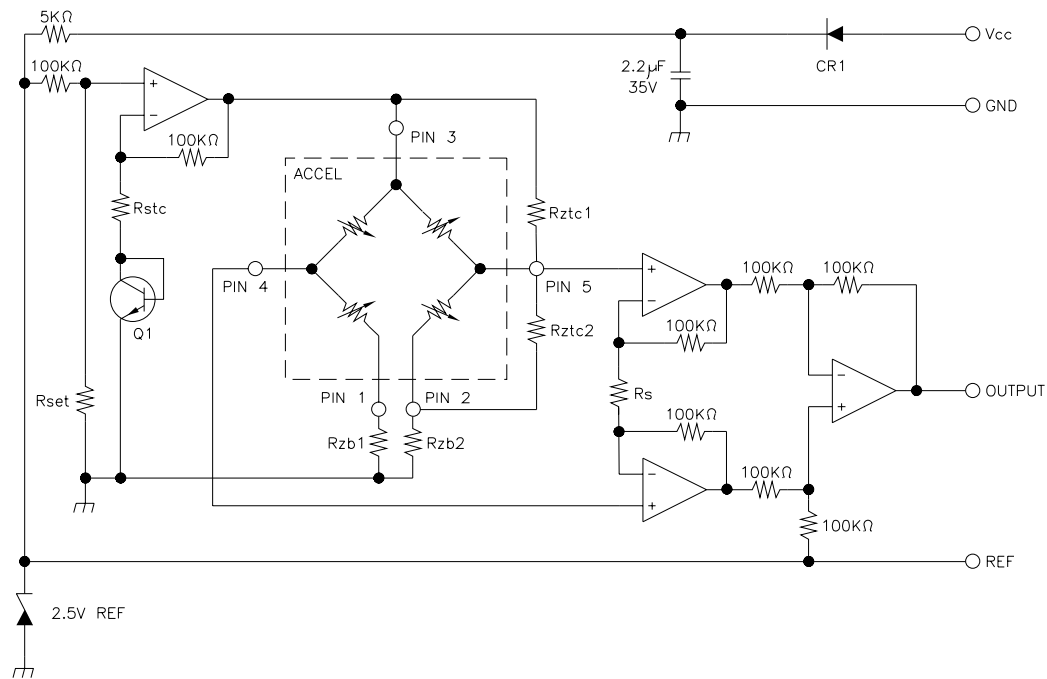

Figure 2. Typical Temperature Compensation and Amplification Circuit (component values specified for each sensor)

Q1: 2N3904
 CR1: 1N914 or equivalent
 Op Amps: LT1014, LM324 or equivalent

- Rstc sets the excitation voltage ramp to compensate the sensitivity error due to temperature.
- Rset sets the excitation voltage to 5V at 25°C.
- Rzb1, Rzb2 and Rztc1 and Rztc2 calibrate the zero offset and compensate the offset error due to temperature.
- Rs calibrates the output span.
- Vcc must be >8 VDC.

Model 3022

PERFORMANCE SPECIFICATIONS

Supply Voltage: 5.0 VDC

Ambient Temperature: 25°C (Unless otherwise specified)

PARAMETERS	RANGE				UNITS	NOTES
	±2G	±5G	±10G	±20G		
Frequency Response [MIN]	0-250	0-300	0-400	0-600	Hz	1, 9
Mounted Resonant Frequency [MIN]	700	800	1000	1500	Hz	8, 9
Sensitivity (MIN/MAX)	8.0/20.0	6.0/15.0	3.0/6.0	1.5/3.0	mV/g	2

PARAMETERS	RANGE				UNITS	NOTES
	±50G	±100G	±200G	±500G		
Frequency Response [MIN]	0-1000	0-1500	0-2000	0-2400	Hz	1, 9
Mounted Resonant Frequency [MIN]	2000	3000	4000	5000	Hz	8, 9
Sensitivity (MIN/MAX)	0.6/1.5	0.3/0.6	0.15/0.3	0.06/0.15	mV/g	2

PARAMETERS	MIN	TYP	MAX	UNITS	NOTES
Zero Acceleration Output		5.0	25.0	±mV	9
Damping Ratio	0.4	0.7	0.9		8, 9
Non-linearity		0.5	1.0	±% Span	4
Transverse Sensitivity		1.0	3.0	±% Span	
Input & Output Resistance	2.5	3.5	6.5	kΩ	9
Temperature Error - Span		1.0	2.0	±% Span	3, 5
Temperature Error - Zero		1.0	2.0	±% Span	3, 5
Supply Voltage		5.0	10.0	VDC	
Output Noise		1.0		µV p-p	6
Output Load Resistance	5			MΩ	
Acceleration Limits (Any Direction)		20X		Rated	7
Operating Temperature	-40°C to +125°C				
Storage Temperature	-55°C to +150°C				
Weight	6.5 Grams				
Materials	Alumina ceramic substrate with alumina ceramic cap				

Notes

- The frequency response is defined as the range of frequencies over which the device sensitivity is within ±5% of the DC value.
- Output voltage increases for positive acceleration; output voltage decreases for negative acceleration.
- Percentage values are with external compensation. The uncompensated temperature coefficients are measured and specified with each unit. In addition, the values of the resistors that provide a temperature compensated output are provided with each unit. These resistors are for use in the circuit shown in Figure 2.
- Best Fit Straight Line. For full scale ranges of 10g or less, the maximum non-linearity is ±2%.
- Compensated temperature range: 0-50°C in reference to 25°C.
- 10 Hz to 1 kHz.
- 400g for ±2g, ±5g, and ±10g versions. 20X or 2000g for other versions, whichever is less.
- For sensors having a resonant frequency greater than 5 kHz, the calibration data sheet will indicate ">5 kHz." In addition, the damping ratio will indicate N/A.
- Actual test data for this parameter is included on the calibration sheet provided with each sensor. A sample of this calibration sheet is shown as Figure 1.

DIMENSIONS

N TYPE

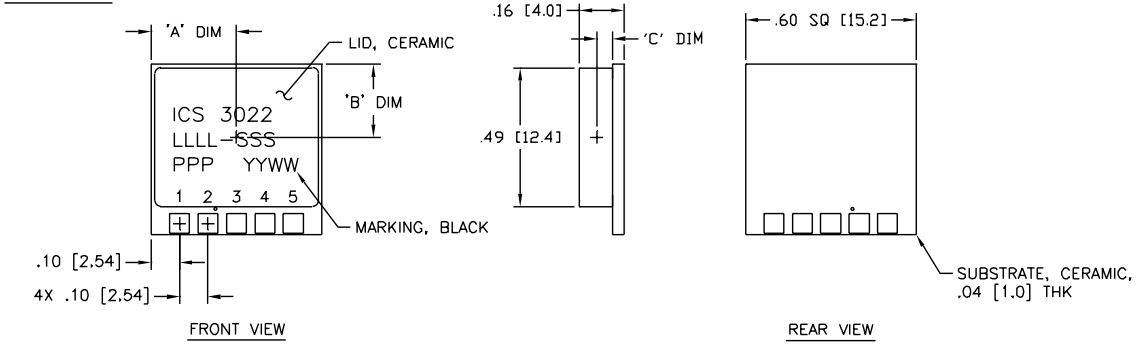

P TYPE

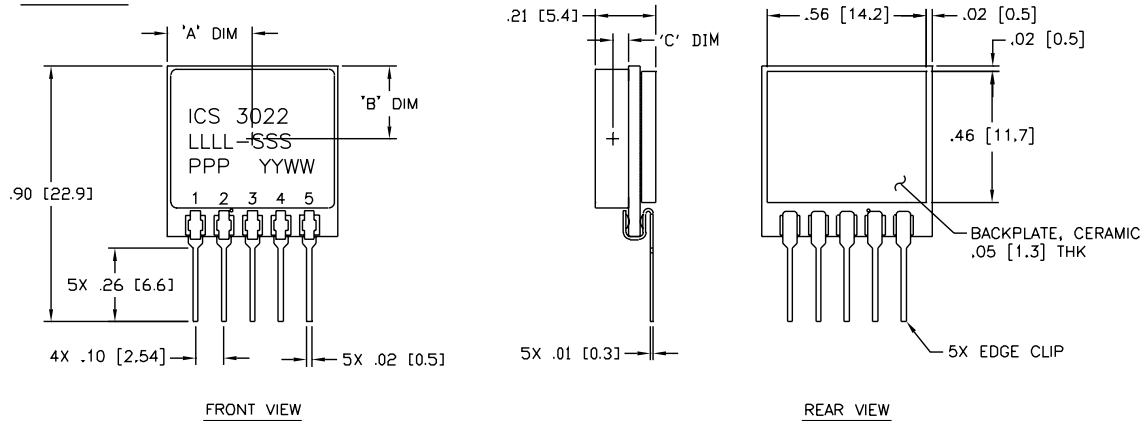

ALL DIMENSIONS ARE IN INCHES [mm]

LTR	2 - 10 g	20 - 500 g
"A" DIM	0.300 ± 0.005 [7.62 ± 0.13]	0.265 ± 0.005 [6.73 ± 0.13]
"B" DIM	0.250 ± 0.005 [6.35 ± 0.13]	0.240 ± 0.005 [6.10 ± 0.13]
"C" DIM	0.032 ± 0.004 [0.81 ± 0.10]	0.032 ± 0.004 [0.81 ± 0.10]

ORDERING INFORMATION

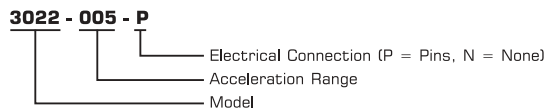

CONNECTIONS

