

ATS672LSB

Preliminary – Subject to Change

PIN OUT DIAGRAM

4 3 2 1

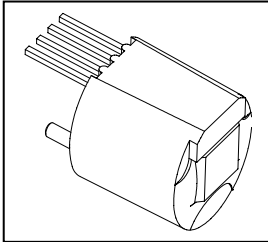

Pin 1: V_{CC}
 Pin 2: V_{OUT}
 Pin 3: Test Pin (Tie to GND)
 Pin 4: Gnd

ABSOLUTE MAXIMUM RATINGS

Supply Voltage, V_{CC}	28 V
Reverse Supply Voltage, V_R	-18 V
Reverse Current Through Output, I_R	50 mA
Continuous Output Current, I_{OUT}	20 mA
Storage Temperature, T_S	170° C
Package Power Rating, $R_{\theta JA}$	~150°C/W
Maximum Junction Temperature, T_{Jmax}	170° C
Maximum Junction Temperature – 100 Hours, T_{Jmax}	180° C

Self-Calibrating TPO Gear-Tooth Sensor with 9-Bit Signal Capture

The ATS672LSB true zero-speed gear-tooth sensors are optimized Hall IC/magnet configurations packaged in a single in-line package (SIP) that provides a user-friendly solution for digital gear-tooth-sensing applications. The SIP module consists of an over-molded package, which holds together a samarium cobalt magnet, a pole piece and a true zero-speed Hall IC that has been optimized to the magnetic circuit. This small package can be easily assembled and used in conjunction with gears of various shapes and sizes.

The sensor incorporates a single-element Hall IC that switches in response to magnetic signals created by a ferrous target. The IC contains a sophisticated digital circuit designed to eliminate the detrimental effects of magnet and system offsets. Signal processing is used to provide zero-speed performance independent of air gap and also to dynamically adapt device performance to the typical operating conditions found in automotive applications (reduced vibration sensitivity). High-resolution (9-bit) peak-detecting DACs are used to set the adaptive switching thresholds of the device. Hysteresis in the thresholds reduces the negative effects of any anomalies in the magnetic signal (such as magnetic overshoot).

The ATS672LSB also includes a low-bandwidth filter that increases the noise immunity and the signal-to-noise ratio of the sensor. These features result in potential improvements in both the timing accuracy and the jitter performance of the device. The ATS672LSB sensor system is optimized for cam applications. Four versions of this device are available. The sensor can be chosen to have a high or low output signal in response to a “tooth”. The sensor is also available with and without TPOS (true power on state) capability. The low-on-tooth sensor without TPOS is available through general sales. (Part # ATS672LSB-LN). For other versions please contact the factory. Some restrictions may apply.

FEATURES

- ♦ Tight timing accuracy over temperature
- ♦ True zero-speed operation
- ♦ True power-on sensing
- ♦ Air gap independent switch points
- ♦ High vibration immunity
- ♦ Large operating air gaps
- ♦ Operation down to 3.3 V
- ♦ Digital output representing target profile
- ♦ Single-chip solution for high reliability
- ♦ Small mechanical size
- ♦ Optimized Hall IC magnetic system
- ♦ AGC and reference-adjust circuit
- ♦ Undervoltage lockout

ATS672LSB

SELF-CALIBRATING TPOS GEAR-TOOTH SENSOR WITH 9-BIT SIGNAL CAPTURE

Preliminary – Subject to Change

OPERATING CHARACTERISTICS Valid at $T_A = -40^{\circ}\text{C}$ to $+150^{\circ}\text{C}$ and power supply within specification unless otherwise noted

Characteristics	Symbol	Test Conditions	Limits			
			Min.	Typ.	Max.	Units
ELECTRICAL CHARACTERISTICS						
Supply Voltage	V_{CC}	Operating; $T_J < T_{Jmax}$	3.3		26.5	V
Reverse Supply Voltage	V_{RCC}	$I_{RCC} = -5 \text{ mA (max)}$			-18	V
Supply Zener Clamp Voltage	V_Z		28	33	37	V
Supply Zener Current	I_Z	$T_J < T_{Jmax}$; pulsed			100	mA
Supply Current	I_{CC}	Output = off	3.0	6.5	11	mA
		Output = on	3.0	6.5	11	mA
POWER-ON STATE CHARACTERISTICS						
Power Up Time	t_{PO}	Gear Speed $< 100 \text{ rpm}$; $V_{CC} > 3.3 \text{ V}$	-		500	μs
Under Voltage Lockout	V_{UV}		-		$< V_{CCMin}$	V
OUTPUT STAGE						
Low Output Voltage	V_{OUT}	$I_{OUT} = 15 \text{ mA}$, Output = on	-	0.2	0.45	V
Output Current Limit	I_{lin}	Output = ON, $T_J < T_{Jmax}$	25	45	70	mA
Output Leakage Current	I_{OFF}	Output = off, $V_{OUT} = V_{CC(Max)}$	-		10	μA
Output Rise Time	t_r	$R_L = 500 \Omega$, $C_L = 10 \text{ pF}$, $T_A = 25^{\circ}\text{C}$	-	0.9	5.0	μs
Output Fall Time	t_f	$R_L = 500 \Omega$, $C_L = 10 \text{ pF}$, $T_A = 25^{\circ}\text{C}$	-	0.5	5.0	μs

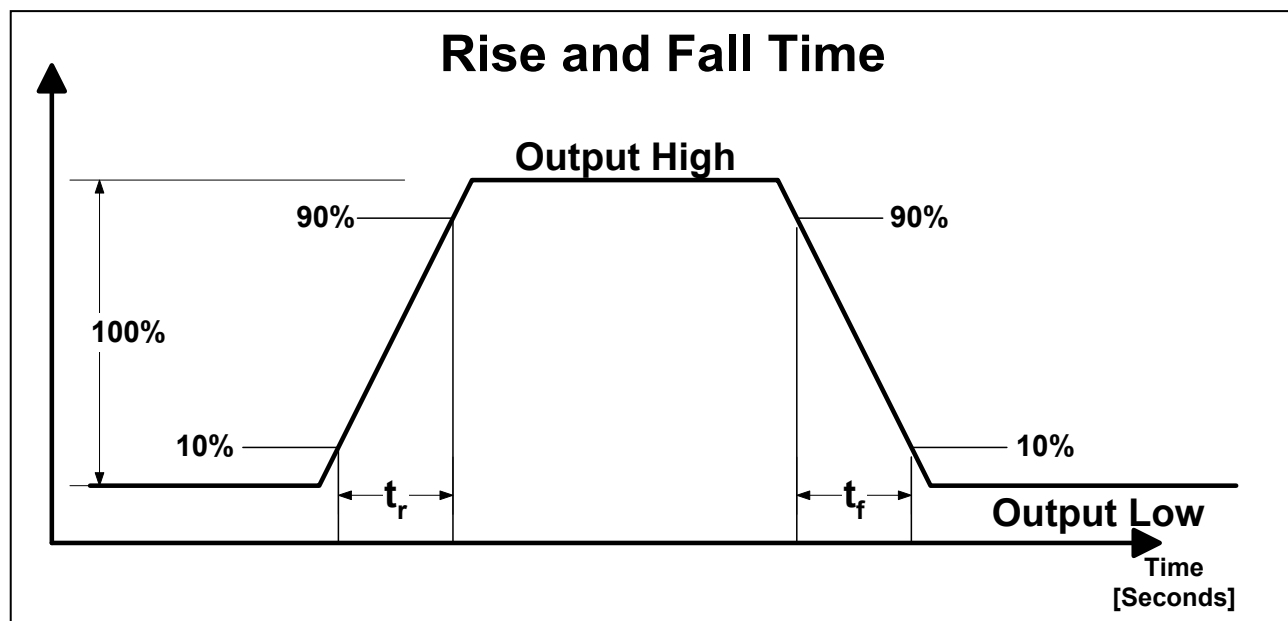

ATS672LSB
SELF-CALIBRATING TPOS GEAR-TOOTH SENSOR WITH 9-BIT SIGNAL CAPTURE
Preliminary – Subject to Change

Characteristics	Symbol	Test Conditions	Limits			Units
			Min.	Typ.	Max.	
SWITCH POINT CHARACTERISTICS						
Tooth Speed	S_{max}		0		8.0	kHz
Bandwidth	f-3db			40		kHz
Operate Point	Bop%	% of peak to peak referenced to tooth signal, AG < Agmax;		+30		%
Release Point	Brp%	% of peak to peak referenced to tooth signal, AG < Agmax;		+40		%
Output Polarity ATS672LSB-LN (no TPOS) ATS672LSB-LT (with TPOS)*	V_{OUT}	Over valley		HIGH		
		Over tooth		LOW		
Output Polarity ATS672LSB-HN (no TPOS)* ATS672LSB-HT (with TPOS)*	V_{OUT}	Over valley		LOW		
		Over tooth		HIGH		

* Restrictions on availability may apply.

Calibration				
Initial Calibration	C_i	Number of rising mechanical edges for accurate edge detection	3	Edges
AGC Disable	C_f	Number of rising mechanical edges required to complete AGC calibration	3	Edges

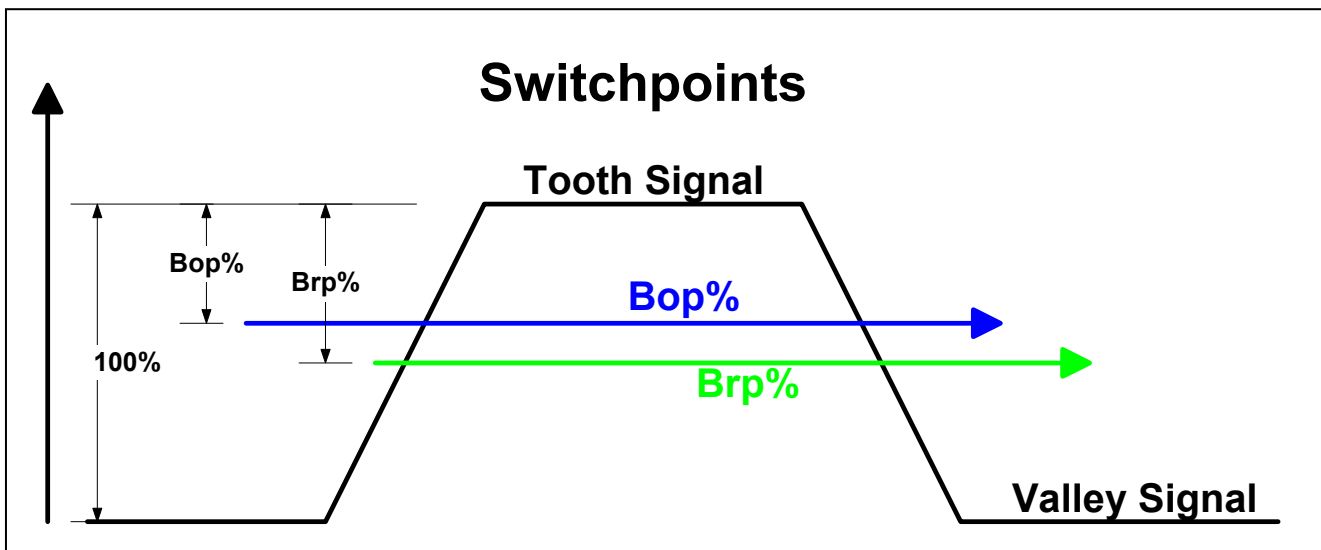

ATS672LSB
SELF-CALIBRATING TPOS GEAR-TOOTH SENSOR WITH 9-BIT SIGNAL CAPTURE
Preliminary – Subject to Change

OPERATION WITH 8X Reference Target over Operational Air Gap and Temperature with Test Circuit #1 Unless Otherwise Stated

Characteristics	Symbol	Test Conditions	Limits			Units
			Min.	Typ.	Max.	
¹ Relative Timing Accuracy	t_{ICRel}	Rising and falling edge, RPM = 1000 during initial calibration gear eccentricity < 0.1 mm		3.0	6.0	°
	t_{Rel}	Rising mechanical edge after initial calibration, RPM = 1000 gear eccentricity < 0.1 mm	-	0.3	0.6	°
	t_{Rel}	Falling mechanical edge after initial calibration, RPM = 1000 gear eccentricity < 0.1 mm	-	0.5	0.8	°
² Absolute Timing Accuracy	$t_{AbsRise}$	Rising mechanical edge air gap: 1.5mm, temperature: 25°C RPM: 1000	-	-0.2	-	°
	$t_{AbsFall}$	Falling mechanical edge air gap: 1.5mm, temperature: 25°C RPM: 1000	-	+0.6	-	°
³ Phase Delay	$t_{RelSpeed}$	After initial calibration air gap: 1.5 mm, temperature: 25°C	-	6.66	-	$\times 10^{-5}$ / RPM
⁴ TPOS Air Gap Min ATS672LSB – LT and HT	AG_{Min}	Valleys may be detected as teeth: incorrect TPOS	-	-	0.5	mm
⁵ TPOS Air Gap Range ATS672LSB – LT and HT	AG_{TPOS}	Distance for correct TPOS functionality	0.5	-	2.25	mm
⁶ TPOS Air Gap Max ATS672LSB – LT and HT	AG_{Max}	Teeth may be detected as a valley: incorrect TPOS	2.25	-	5.0	mm
Operational Air Gap Range	AG	Output switching: running mode only	0.5	-	2.25	mm
Edge Repeatability	$t_{\theta E}$	360° repeatability, 1000 edges		0.04		°

¹ Relative Timing Accuracy Range is the change in edge position over the operational air gap and temperature range that can be expected from a single device. This does not include part-to-part variation.

² The Typical Absolute Timing Accuracy is the difference between the target mechanical edge (rising or falling) and the corresponding sensor electrical edge.

³ Phase Delay is the change in edge position over the operational RPM range that can be expected from a single device. This does not include part-to-part variation or variation due to temperature.

⁴ The TPOS Air Gap Min is the Installation Air Gap where the device may detect Valleys as Teeth. The True Power On Function is **NOT** guaranteed to operate.

⁵ The TPOS Air Gap Range is the Installation Air Gap Range where the True Power On Function is guaranteed to operate. Operating is defined as correctly detecting a tooth when powered up over a tooth and correctly detecting a valley when powered up over a valley using the Reference Target. This specification is only valid for targets that meet or exceed the 'Gear Parameters for Correct TPOS Operation' section of this document.

⁶ The TPOS Air Gap Max is the Installation Air Gap where the device may detect a Tooth as a Valley. The True Power On Function is **NOT** guaranteed to operate.

ATS672LSB

SELF-CALIBRATING TPOS GEAR-TOOTH SENSOR WITH 9-BIT SIGNAL CAPTURE

Preliminary – Subject to Change

Relative Timing Accuracy

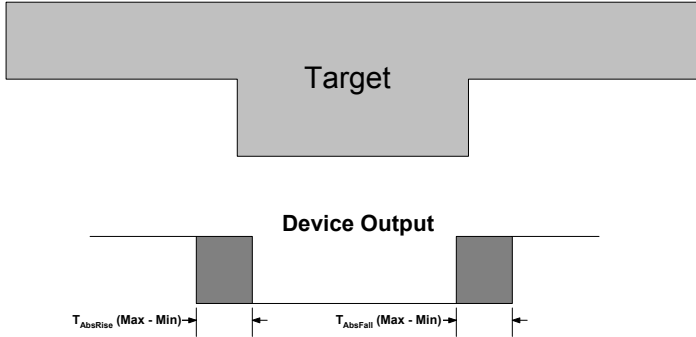

Absolute Timing Accuracy

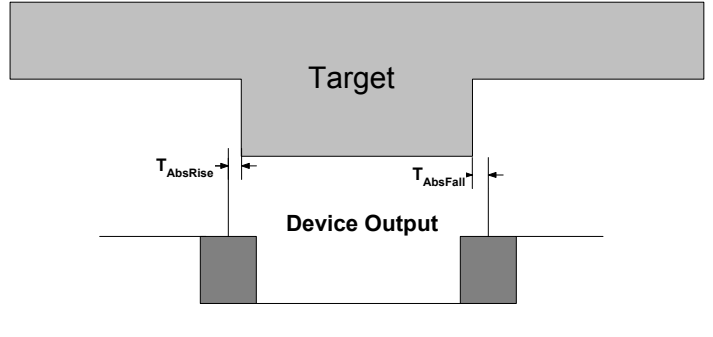

Operational Air Gap

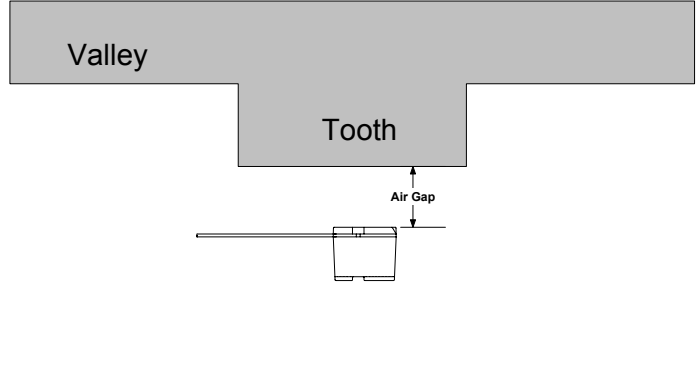

TPOS Air Gap

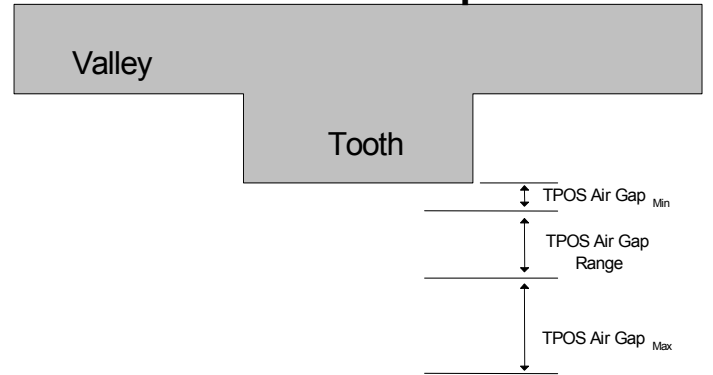

Phase Delay with RPM

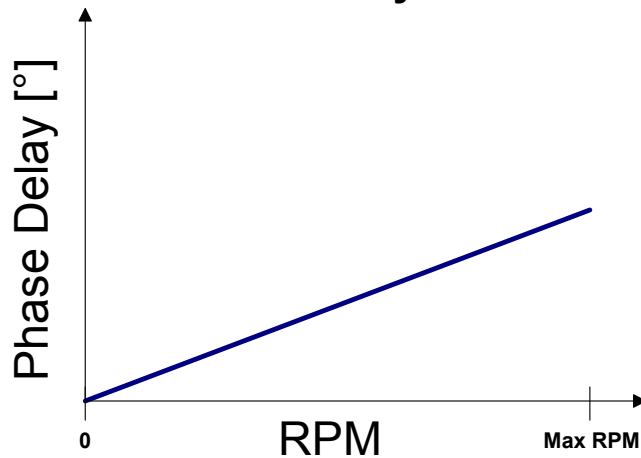

ATS672LSB
SELF-CALIBRATING TPOS GEAR-TOOTH SENSOR WITH 9-BIT SIGNAL CAPTURE
Preliminary – Subject to Change

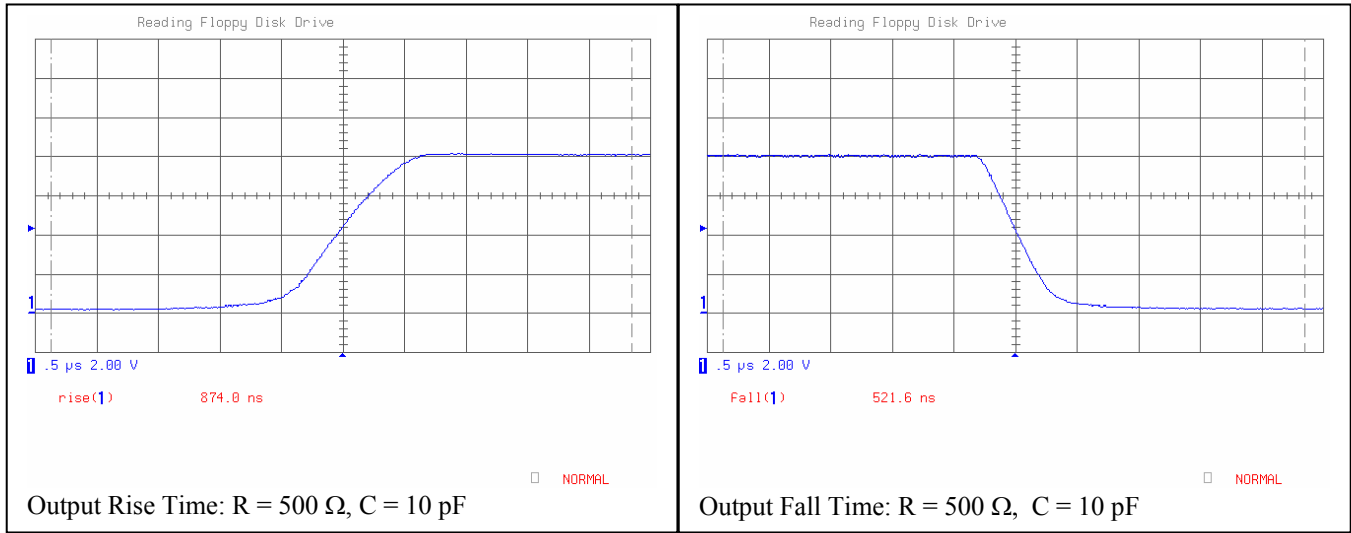

ATS672LSB
SELF-CALIBRATING TPOS GEAR-TOOTH SENSOR WITH 9-BIT SIGNAL CAPTURE
Preliminary – Subject to Change

Reference Target Dimensions

Target	Diameter (D _o)	Thickness (F)	Tooth Width (T)	Valley Width (P _c – T)	Valley Depth (h _t)
Reference Target	120 mm	6.0 mm	23.6 mm	23.6 mm	5.0 mm

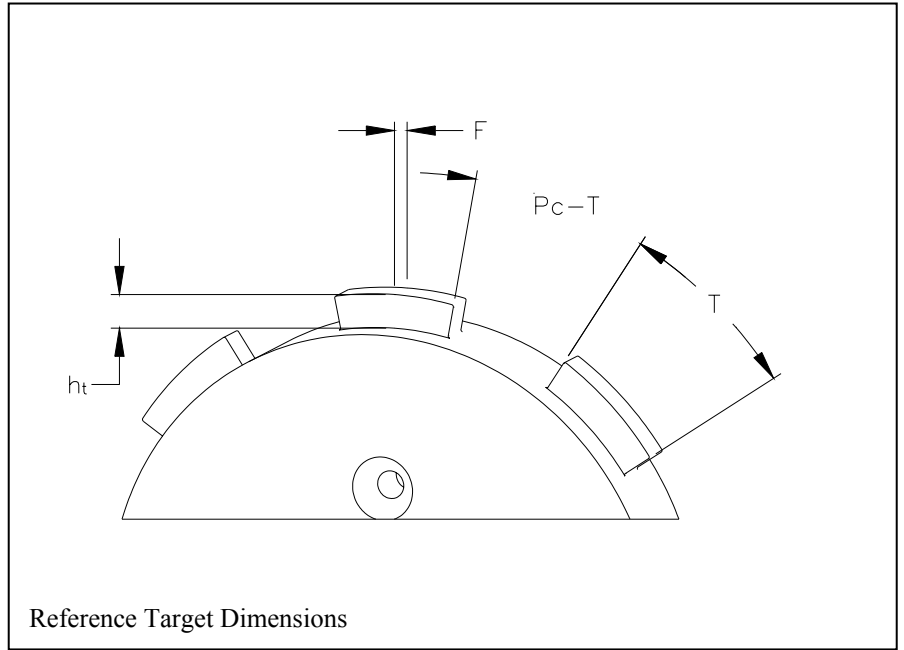
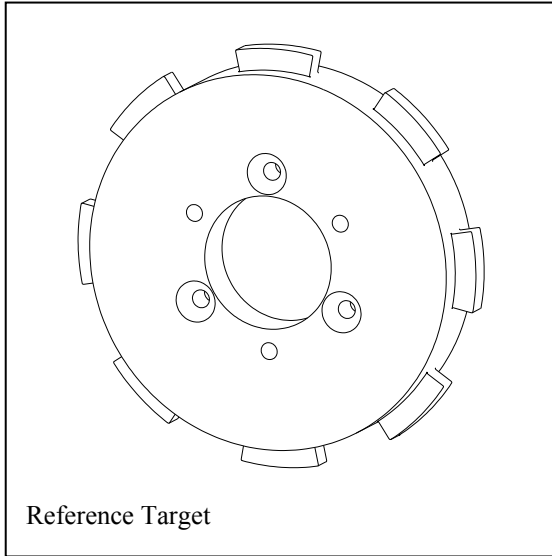

GEAR PARAMETERS FOR CORRECT TPOS OPERATION

Characteristic	Description	Limits			
		Min.	Typ.	Max.	Units
Valley Depth (h _t)	Depth of target valley	5.0	-	-	mm
Valley Width (P _c – T)	Length and width of target valley	13	-	-	mm
Tooth Width (T)	Width of target tooth	5.0	-	-	mm
Thickness (F)	Thickness or length of target tooth	5.0	-	-	mm

¹MATERIAL PROPERTIES: CRS 1018

¹ The target must generate a minimum of 120 gauss difference between the tooth field and the valley field at the Maximum Installation Air Gap. With the material and dimensions mentioned above the target will generate the required 120 gauss.

ATS672LSB
SELF-CALIBRATING TPOS GEAR-TOOTH SENSOR WITH 9-BIT SIGNAL CAPTURE
Preliminary – Subject to Change

MECHANICAL INFORMATION

Component	Material	Function	Value
Sensor Package Material	SmCo – R22		8 mm D x 4 mm L
	Thermoset epoxy	Max. temperature	170°C ¹
Leads	Copper, 0.016" dia, 0.050" spacing		
Lead Coating	Solder, tin / lead 90/10 ²		

¹ Temperature excursions of up to 225°C for 2 minutes or less are permitted.

² All industry accepted soldering techniques are acceptable for this sub-assembly as long as the indicated maximum temperatures for each component are not exceeded.

DEVICE QUALIFICATION PROGRAM

Test Name	Test Conditions	Test Length	# of Lots	Sample / lot	Comments
High Temperature Operating Life	AEC-Q100 #2 (JA108) Ta = 150°C, Tj = 165°C	408 hrs	3	77	
High Temperature Bake	AEC-Q100 #3 (JA103) Ta = 170°C	1000 hrs	3	77	
Temperature Humidity Bias	AEC-Q100 #5 (JA101) 85°C/85%RH	1008 hrs	3	77	
Autoclave	AEC-Q100 #6 (JA102)	96 hrs	3	77	
Temperature Cycling	AEC-Q100 #7(JA104)	500 cycles	3	77	-65°C to +160°C, 30 sec. transition, 30 minute dwell
ESD	AEC-Q100 #20 (AEC-Q100-002, AEC-Q100-003)	-	1	3/model/step	HBM & MM
Early Life Failure Rate	AEC-Q100 #25 (AEC-Q100-008)	150°C/24 hrs	3	800	
Thermal Shock	-40°C to +150°C, 1 minute transition, 10 minute dwell	100 cycles	3	77	

ATS672LSB
SELF-CALIBRATING TPOS GEAR-TOOTH SENSOR WITH 9-BIT SIGNAL CAPTURE
 Preliminary – Subject to Change

Functional Block Diagram

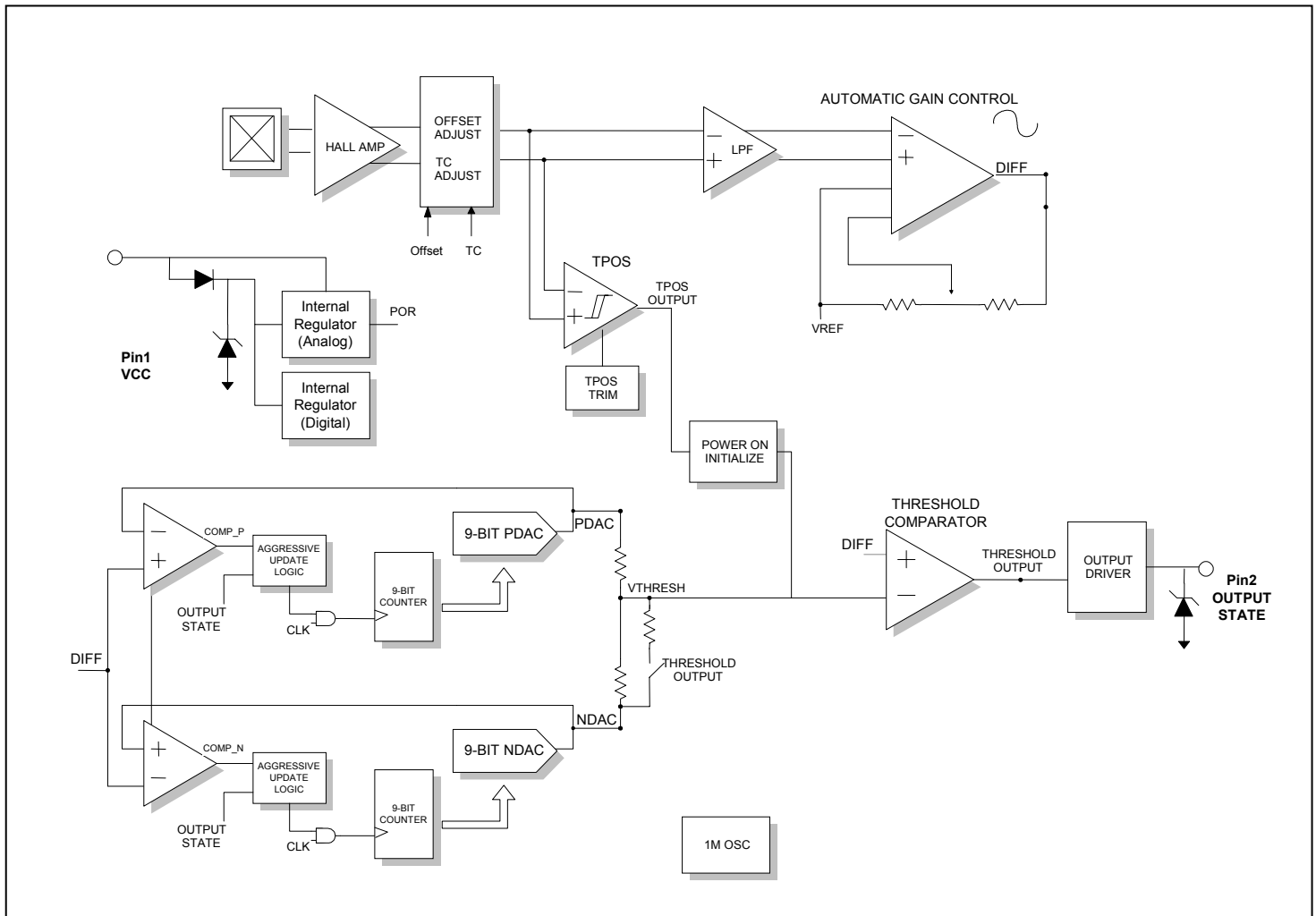

ATS672LSB

SELF-CALIBRATING TPOS GEAR-TOOTH SENSOR WITH 9-BIT SIGNAL CAPTURE

Preliminary – Subject to Change

EMC CAPABILITY

All EMC tests shall be conducted at 23±5°C

Test Name	Reference Specification	Circuit Parameters	Performance			
			I	II	III	IV
	ISO 7637-1, Test Level					
Inductive transient	ISO 7637-1, Test pulse 1	Test circuit #1	-	-	-	C
Inductive transient	ISO 7637-1, Test pulse 2	Test circuit #1	-	-	-	C
Switching transients	ISO 7637-1, Test pulses 3a & 3b	Test circuit #1	-	-	-	A
Low voltage drop-out	ISO 7637-1, Test pulse 4	Test circuit #1	-	-	-	A
Load dump transient	ISO 7637-1, Test pulse 5	Test circuit #1	A	C	¹ C	E
Starting transient	ISO 7637-1, Test pulse 6	Test circuit #1	-	-	¹ C	E
Power-off transient	ISO 7637-1, Test pulse 7	Test circuit #1	-	-	-	C
ESD – Human Body Model (HMB)	AEC-Q100-002	No additional components	Passes to +/- TBD			
ESD – Machine Model (MM)	AEC-Q100-003	No additional components	Passes to +/- TBD			
Direct RF Injection	ISO 11452-7	Test circuit #1	TBD			
Bulk Current Injection	ISO 11452-4	Test circuit #1	TBD			
TEM Cell	ISO 11452-3	Test circuit #1	Passes to 200 V/m			

Test circuits for electromagnetic compatibility and Typical Operating Schematic

Test circuit 1

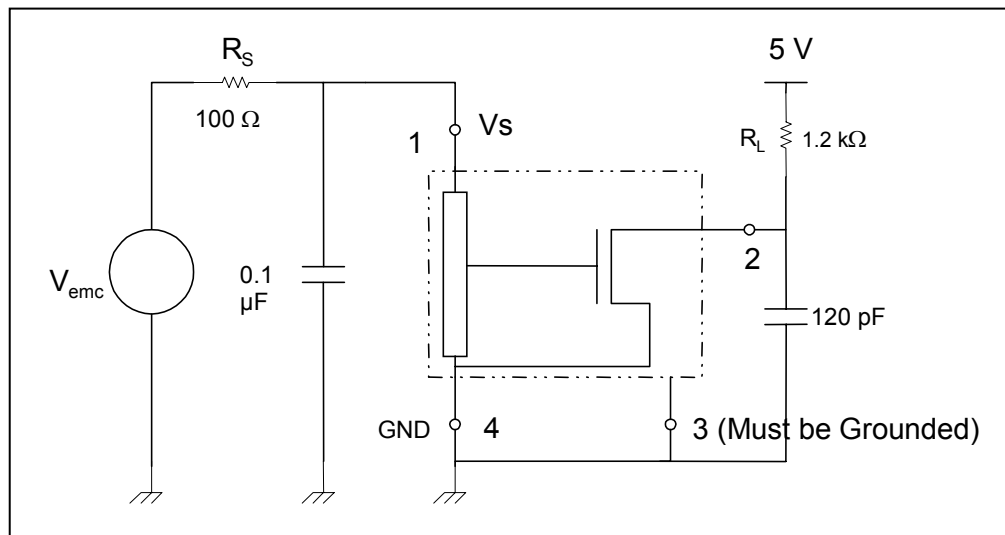

¹ Additional protection circuitry is required to protect the device from destruction above this voltage level.

Power Derating Curve: ATS672LSB Package

Power Derating

Due to internal power consumption, the temperature of the IC (junction temperature, T_j) is higher than the ambient environment temperature, T_a . To ensure that the device does not operate above the maximum rated junction temperature use the following calculations:

$$\Delta T = P_D * R_{\theta JA}$$

Where $P_D = V_{CC} * I_{CC}$

$$\therefore \Delta T = V_{CC} * I_{CC} * R_{\theta JA}$$

Where ΔT denotes the temperature rise resulting from the IC's power dissipation:

$$T_j = T_A + \Delta T \quad R_{\theta JA} = 150^\circ\text{C/W} \quad T_{j(\text{max})} = 170^\circ\text{C}$$

Typical T_j Calculation:

$T_A = 25^\circ\text{C}$, $V_{CC} = 5\text{ V}$, $I_{CC}(\text{On}) = 6.5\text{ mA}$

$$P_D = V_{CC} * I_{CC}$$

$$P_D = 5\text{ V} * 6.5\text{ mA} = 32.5\text{ mW}$$

$$\Delta T = P_D * R_{\theta JA} = 32.5\text{ mW} * 150^\circ\text{C/W} = 4.9^\circ$$

$$T_j = T_A + \Delta T = 25^\circ\text{C} + 4.9^\circ\text{C} = 29.9^\circ\text{C}$$

Maximum Allowable Power Dissipation Calculation

$$T_j = T_A + \Delta T$$

$T_j(\text{max}) = 170^\circ\text{C}$, if $T_A = 160^\circ\text{C}$ then:

$$170 = 160 + \Delta T$$

$$\Delta T = 10^\circ\text{C}$$

$$\Delta T = P_D * R_{\theta JA} \quad (R_{\theta JA} = 150^\circ\text{C/W})$$

$$\therefore P_{D(\text{max})} = 10^\circ\text{C} / 150^\circ\text{C/W} = 66.6\text{ mW} @ T_A = 160^\circ\text{C}$$

Maximum V_{CC} for $P_{D(\text{max})} = 111\text{ mW}$ at $T_A = 160^\circ\text{C}$

$$P_D = V_{CC} * I_{CC} \quad I_{CC} = 10\text{ mA (max) at } 160^\circ\text{C}$$

$$V_{CC} = P_D / I_{CC} = 66.6\text{ mW} / 10\text{ mA} = 6.66\text{ V}$$

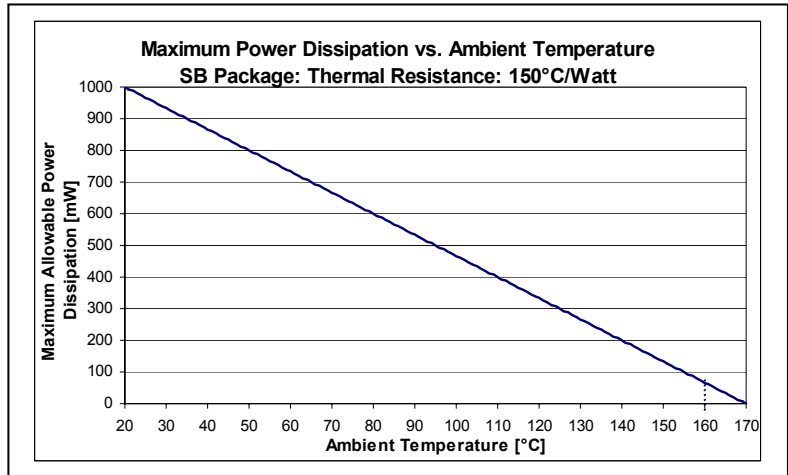

ATS672LSB
SELF-CALIBRATING TPOS GEAR-TOOTH SENSOR WITH 9-BIT SIGNAL CAPTURE
Preliminary – Subject to Change

SB PACKAGE DRAWING

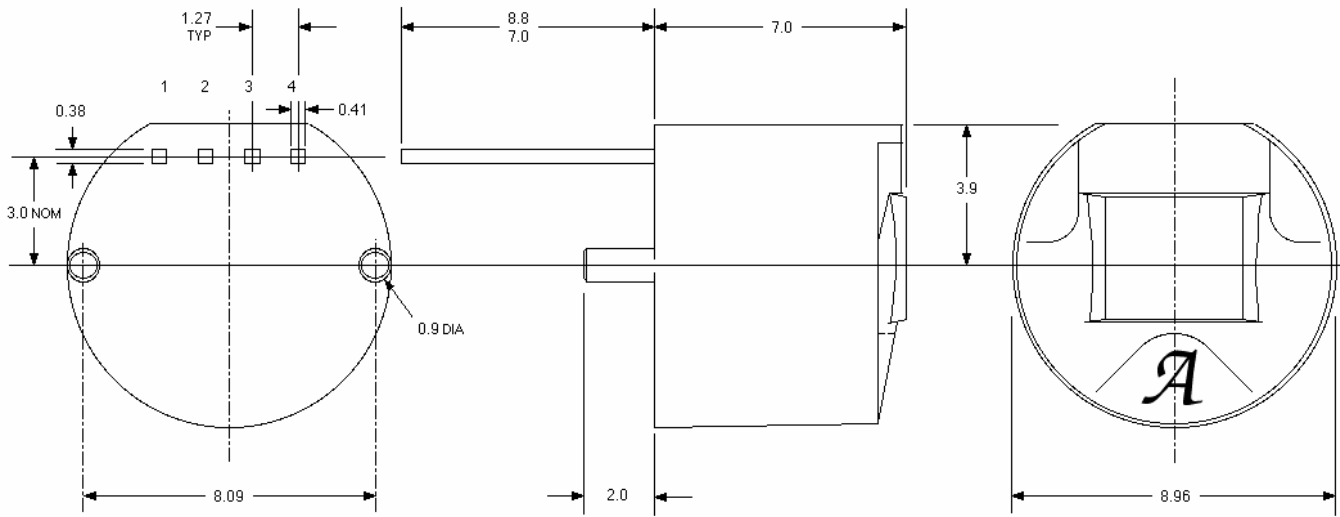

Dwg. MH-017-1B mm

Tolerances unless otherwise specified: 1 place ± 0.1 mm, 2 places ± 0.05 mm
NOTE: Nominal dimensions and tolerances dependent on package material