

# AN7108

## 1-Chip Stereo Pre-Amplifier / Power Amplifier Circuit (3V)

### ■ Description

The AN7108 is a monolithic integrated circuit designed for dual pre and power amplifier suitable for 3V headphone stereo.

### ■ Features

- $V_{CC}$  range :  $V_{CC} = 1.8V \sim 6.0V$
- Voltage gain:  $G_V = 65dB$  (1kHz)
- Incorporation of DC volume, pre-amp. and power amp. in one chip
- Volume Attenuation:  $V_{min} = -80dB$

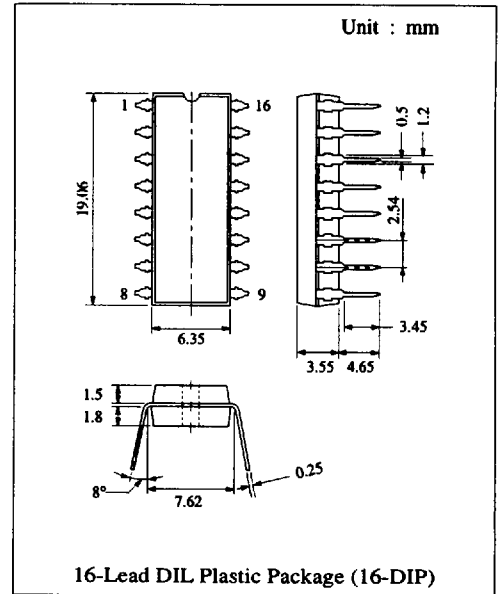

### ■ Block Diagram

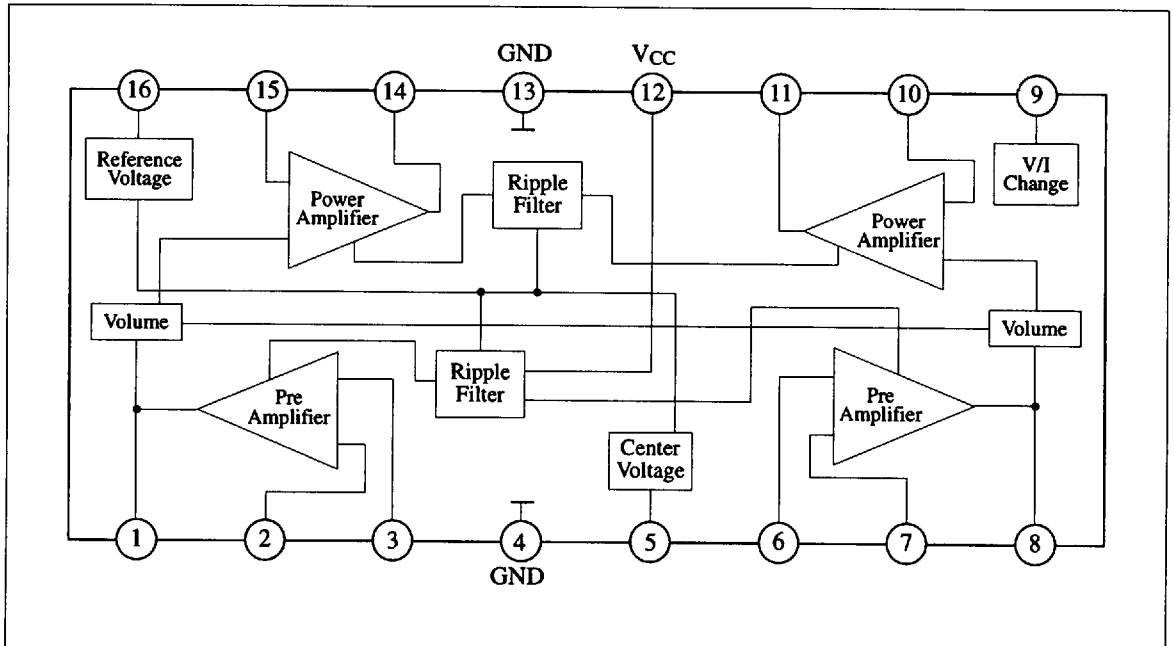

### ■ Absolute Maximum Ratings (Ta=25°C)

Item	Symbol	Rating	Unit
Supply Voltage	V <sub>CC</sub>	7	V
Supply Current	I <sub>CC</sub>	150	mA
Power Dissipation	P <sub>D</sub>	1000	mW
Operating Ambient Temperature	Topr	-20 ~ +75	°C
Storage Temperature	Tstg	-55 ~ +150	°C

Operating Supply Voltage Range: V<sub>CC</sub> = 1.8V ~ 6.0V

### ■ Electrical Characteristics (V<sub>CC</sub>=3V, f=1kHz, R<sub>L</sub>=32Ω, Ta=25°C)

Item	Symbol	Condition	min.	typ.	max.	Unit
Quiescent Circuit Current	I <sub>CQ</sub>	V <sub>in</sub> = 0mV	10	14	20	mA
Voltage Gain	G <sub>v</sub>	V <sub>OUT</sub> = 0.3V	62	65	68	dB
Channel Balance	CB	V <sub>OUT</sub> = 0.3V	-1.5	0	1.5	dB
Total Harmonic Distortion	THD	V <sub>OUT</sub> = 0.3V		0.7	1.0	%
Maximum Power Output	P <sub>O(max)</sub>	THD = 10%	25	30		mW
Channel Crosstalk	CT	V <sub>OUT</sub> = 1.0V, R <sub>g</sub> = 2kΩ		-55		dB
Volume Attenuation	V <sub>min</sub>	V <sub>in</sub> = 5mV, Pin 9 = 0V		-80		dB
Output Noise Voltage	V <sub>no</sub>	R <sub>g</sub> = 2.2kΩ, DIN/AUDIO			2	mV
Signal to Noise Ratio	S/N		50			dB
Ripple Rejection	RR	f = 1kHz, V <sub>R</sub> = 33mV		-57		dB

### ■ Pin

Pin No.	Pin Name	Pin No.	Pin Name
1	Pre-Amp. Output Ch.1	9	Volume Control
2	Pre-Amp. Negative Feedback Ch.1	10	Power Amp. Negative Feedback Ch.2
3	Pre-Amp. Input Ch.1	11	Power Amp. Output Ch.2
4	GND-1	12	V <sub>CC</sub>
5	Center Voltage	13	GND-2
6	Pre-Amp. Input Ch.2	14	Power Amp. Output Ch.1
7	Pre-Amp. Negative Feedback Ch.2	15	Power Amp. Negative Feedback Ch.1
8	Pre-Amp. Output Ch.2	16	Reference Voltage

■ Application Circuit

