

2SC4960, 2SC4960A

Silicon NPN triple diffusion planar type

For power switching

■ Features

- High-speed switching
- High collector to base voltage V_{CBO}
- Satisfactory linearity of forward current transfer ratio h_{FE}
- Full-pack package with outstanding insulation, which can be installed to the heat sink with one screw

■ Absolute Maximum Ratings ($T_C=25^\circ\text{C}$)

Parameter	Symbol	Rated	Unit	
Collector to base voltage	2SC4960 2SC4960A	V_{CBO}	900	V
			900	
Collector to emitter voltage		V_{CES}	900	V
Collector to emitter voltage	2SC4960 2SC4960A	V_{CEO}	800	V
			900	
Emitter to base voltage		V_{EBO}	7	V
Peak collector current		I_{CP}	2	A
Collector current		I_C	1	A
Base current		I_B	0.3	A
Collector power dissipation	$T_C=25^\circ\text{C}$ $T_a=25^\circ\text{C}$	P_C	40	W
			3	
Junction temperature		T_j	150	$^\circ\text{C}$
Storage temperature		T_{stg}	-55 to +150	$^\circ\text{C}$

■ Electrical Characteristics ($T_C=25^\circ\text{C}$)

Parameter	Symbol	Conditions	min	typ	max	Unit
Collector cutoff current	I_{CBO}	$V_{CB} = 900\text{V}, I_E = 0$			50	μA
Emitter cutoff current	I_{EBO}	$V_{EB} = 7\text{V}, I_C = 0$			50	μA
Collector to emitter voltage	2SC4960 2SC4960A	V_{CEO}	$I_C = 1\text{mA}, I_B = 0$	800		V
			$I_C = 1\text{mA}, I_B = 0$	900		
Forward current transfer ratio	h_{FE1} h_{FE2}	$V_{CE} = 5\text{V}, I_C = 0.05\text{A}$ $V_{CE} = 5\text{V}, I_C = 0.5\text{A}$	6			
			3			
Collector to emitter saturation voltage	$V_{CE(sat)}$	$I_C = 0.2\text{A}, I_B = 0.04\text{A}$			1.5	V
Base to emitter saturation voltage	$V_{BE(sat)}$	$I_C = 0.2\text{A}, I_B = 0.04\text{A}$			1	V
Transition frequency	f_T	$V_{CE} = 10\text{V}, I_C = 0.05\text{A}, f = 1\text{MHz}$		4		MHz
Turn-on time	t_{on}	$I_C = 0.2\text{A}, I_{B1} = 0.04\text{A}, I_{B2} = -0.08\text{A}, V_{CC} = 250\text{V}$			1	μs
Storage time	t_{stg}				3	μs
Fall time	t_f				1	μs

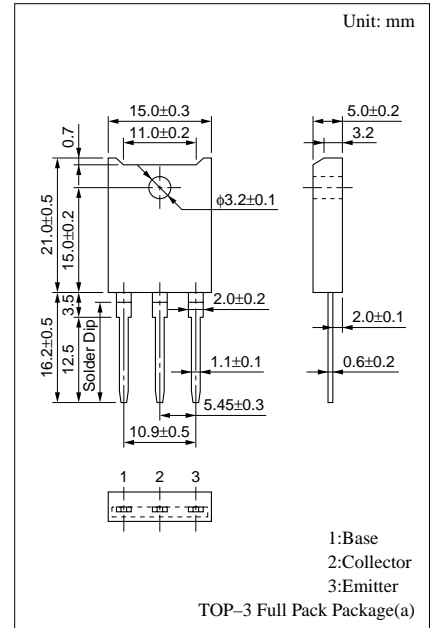

$P_C - T_a$

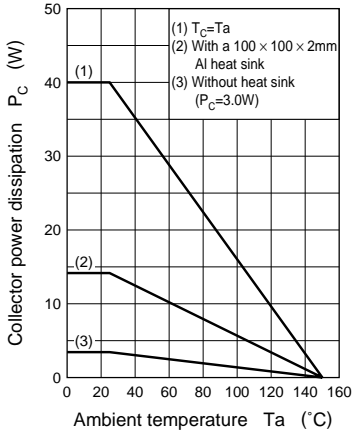

$I_C - V_{CE}$

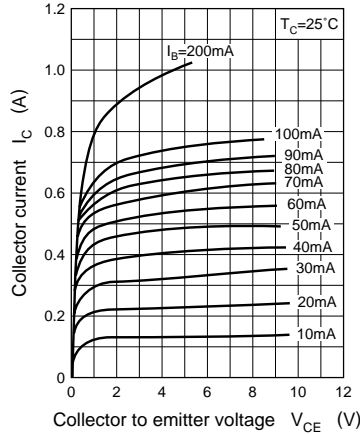

$V_{CE(sat)} - I_C$

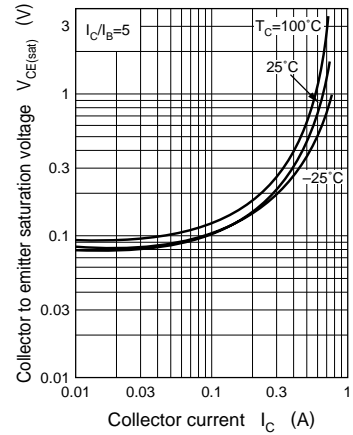

$V_{BE(sat)} - I_C$

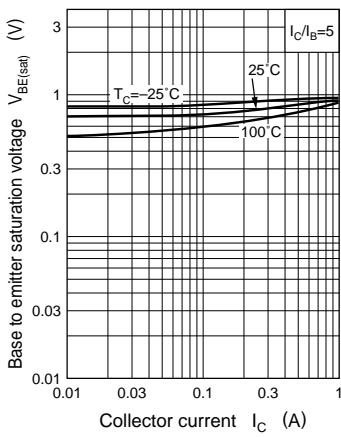

$h_{FE} - I_C$

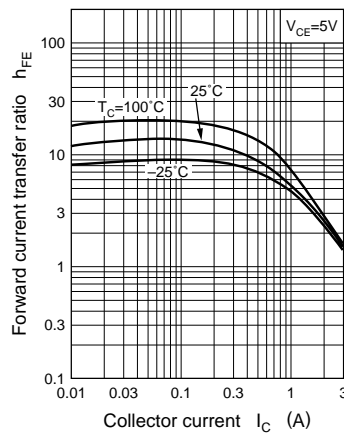

$f_T - I_C$

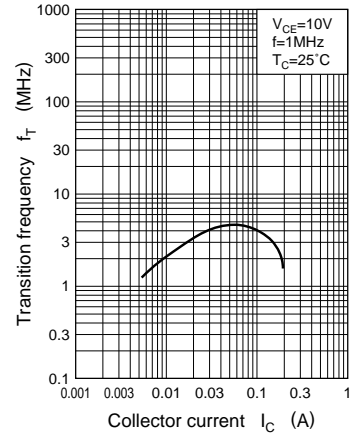

$t_{on}, t_{stg}, t_f - I_C$

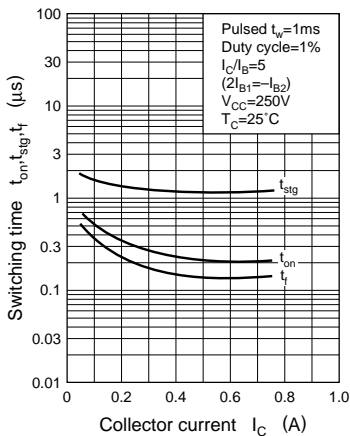

Area of safe operation (ASO)

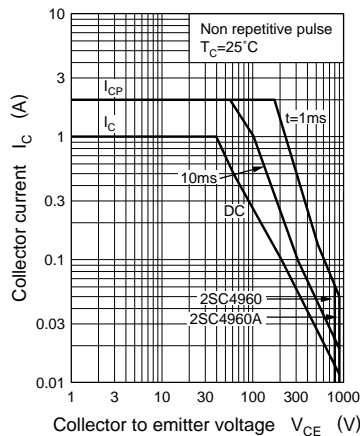

Area of safe operation, reverse bias ASO

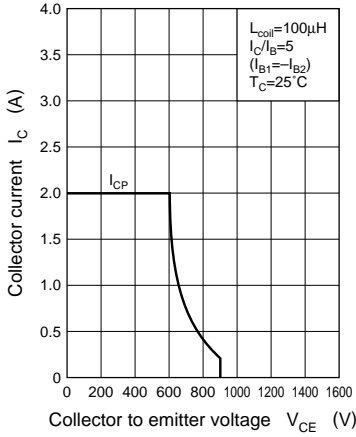

Reverse bias ASO measuring circuit

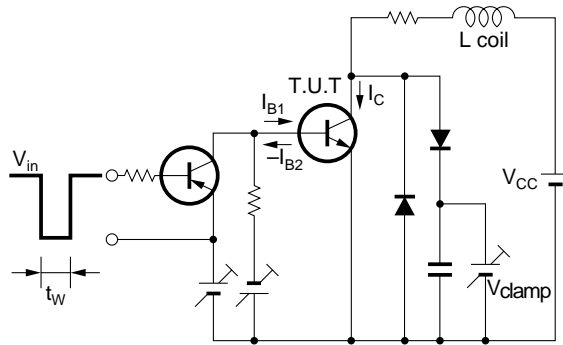

$R_{th(t)} - t$

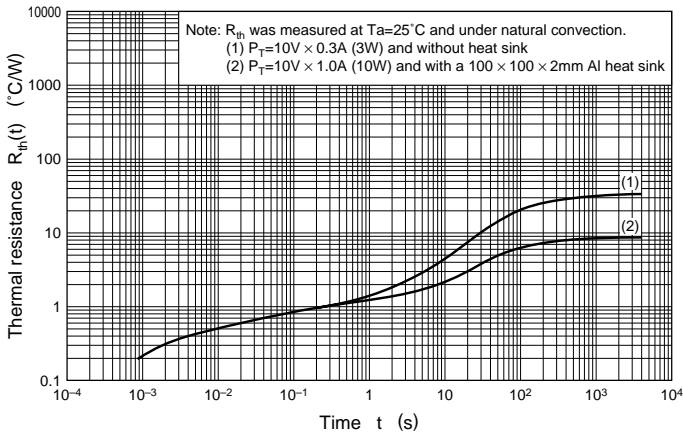

This datasheet has been download from:

www.datasheetcatalog.com

Datasheets for electronics components.