

TG2206F

RF SPDT Switch

Switch The Receive Filter for Mobile Communication
 Switch The Diversity Antenna
 Switch The Local Signal

Features

- Low insertion loss: LOSS = 0.4dB (typ.)
- High isolation: ISL = 28dB (typ.)
- Low voltage operation: $V_C = 0\text{ V}/2.5\text{ V}$
- Small package: SM6 package ($2.9 \times 1.6 \times 1.1\text{ mm}$)

Pin Assignment (top view)

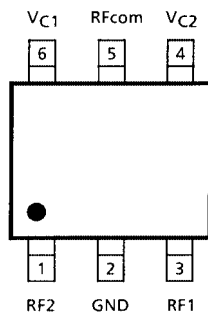

Marking

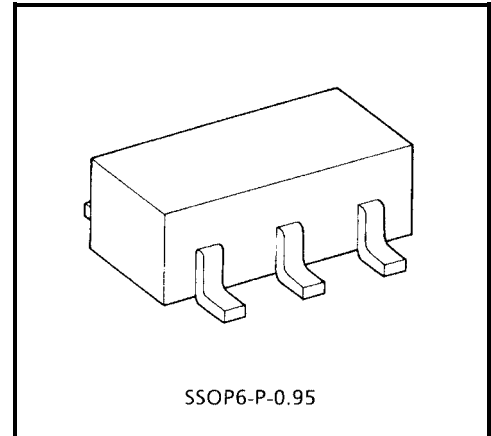
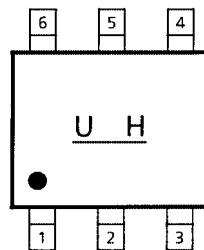

SSOP6-P-0.95

Weight: 0.014 g (typ.)

Maximum Ratings (Ta = 25°C)

Characteristic	Symbol	Rating	Unit
Control voltage	V_{C1}	5	V
	V_{C2}	5	V
Input power	P_i	1	W
Operating temperature range	T_{opr}	-40~85	°C
Storage temperature range	T_{stg}	-55~125	°C

Caution

This device is electrostatic sensitivity. Please handle with caution.

Electrical Characteristics (f = 1 GHz, Ta = 25°C, Zg = Zi = 50 Ω)

Characteristics	Symbol	Test Circuit	Test Condition	Min	Typ.	Max	Unit
Insertion loss	LOSS (1)	1	V _{C1} = 2.5 V, V _{C2} = 0 V, P _i = 0dBmW	—	0.4	0.7	dB
	LOSS (2)	1	V _{C1} = 0 V, V _{C2} = 2.5 V, P _i = 0dBmW	—	0.4	0.7	
Isolation	ISL (1)	1	V _{C1} = 2.5 V, V _{C2} = 0 V, P _i = 0dBmW	25	28	—	dB
	ISL (2)	1	V _{C1} = 0 V, V _{C2} = 2.5 V, P _i = 0dBmW	25	28	—	
Output power at 1dB gain compression	P _{01dB}	1	V _{C1} = 2.5 V, V _{C2} = 0 V or V _{C1} = 0 V, V _{C2} = 2.5 V	15	20	—	dBmW
Control current	I _{C1}	—	V _{C1} = 0 V, V _{C2} = 3 V or V _{C1} = 3 V, V _{C2} = 0 V	—	—	0.01	mA
	I _{C2}	—		—	—	0.01	
Switching time	t _{sw}	—	V _{C1} = 0 V, V _{C2} = 3 V or V _{C1} = 3 V, V _{C2} = 0 V	—	0.01	—	μs

Block Diagram

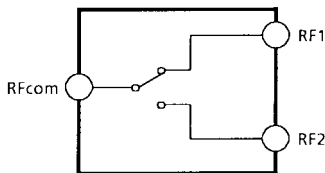

Switch Condition

Control Voltage	Switch Condition
V _{C1} = 2.5 V V _{C2} = 0 V	RF _{Com} - RF1 OFF RF _{Com} - RF2 ON
V _{C1} = 0 V V _{C2} = 2.5 V	RF _{Com} - RF1 ON RF _{Com} - RF2 OFF

Test Circuit 1 (RF Test Circuit)

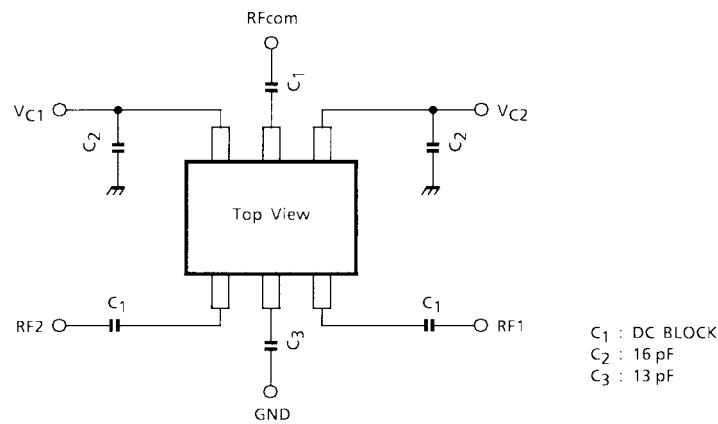

Please fix the value of each capacity for using frequency and circuit.

Notice

The circuits and measurements contained in this document are given only in the context of as examples of applications for these products.

Moreover, these example application circuits are not intended for mass production, since the high-frequency characteristics (the AC characteristics) of these devices will be affected by the external components which the customer uses, by the design of the circuit and by various other conditions.

It is the responsibility of the customer to design external circuits which correctly implement the intended application, and to check the characteristics of the design.

TOSHIBA assume no responsibility for the integrity of customer circuit designs or applications.

Recommend Capacity

	85 MHz	0.8~1 GHz	1.6 GHz	2 GHz
C1	100 pF	100 pF	22 pF	9 pF
C2	100 pF	16 pF	10 pF	9 pF
C3	150 pF	13 pF	4 pF	3 pF

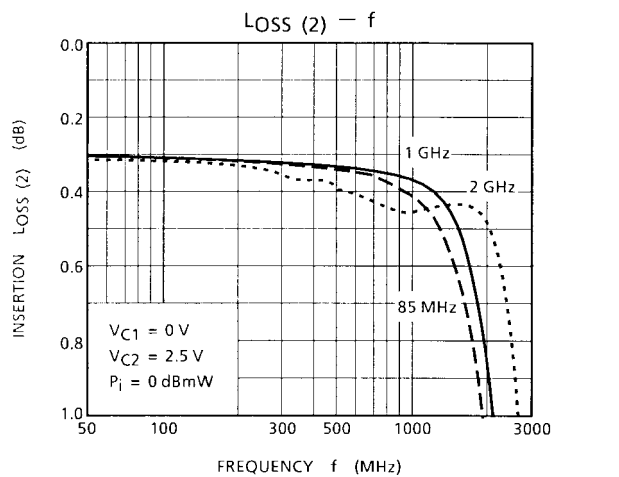
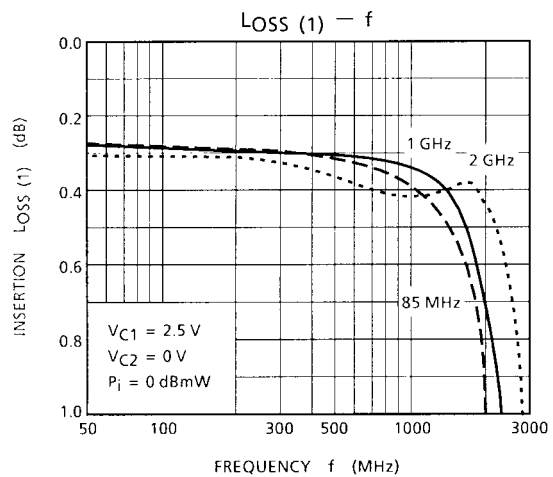
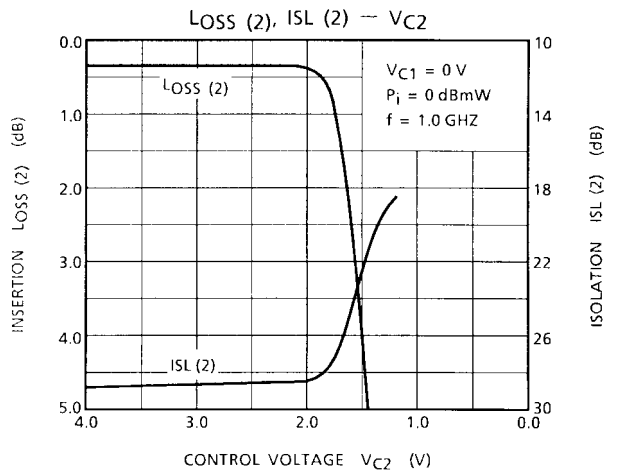
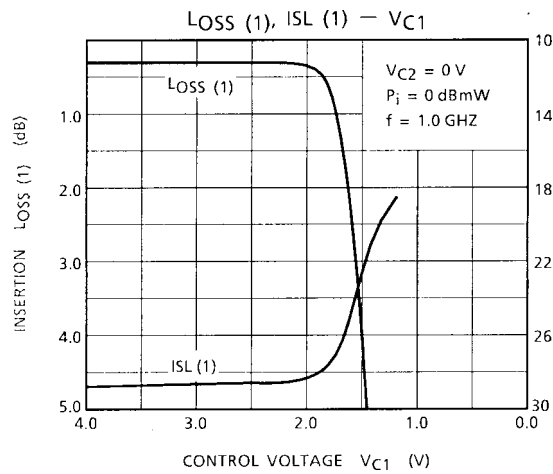
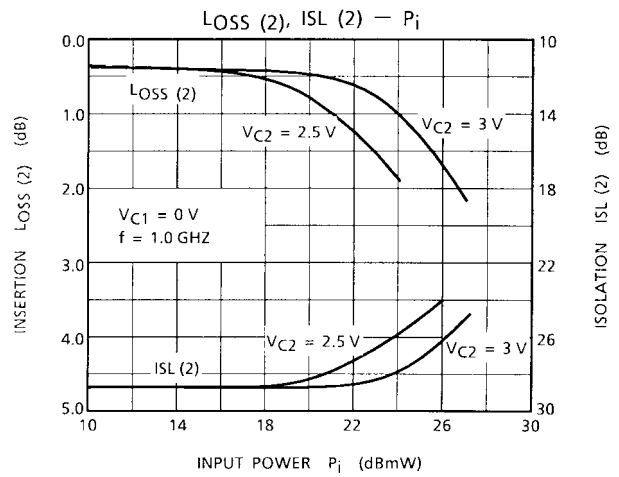
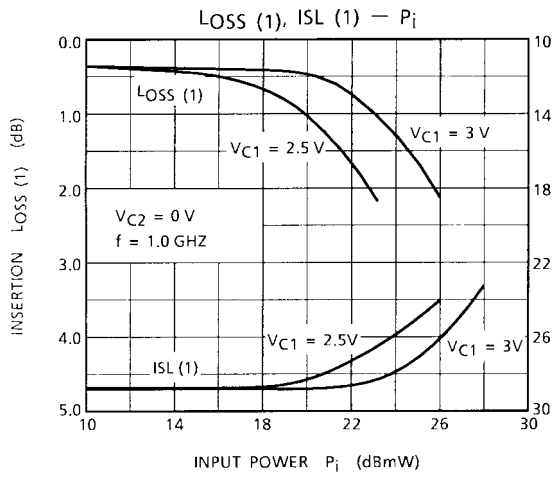

This curve shows the frequency characteristics when recommended capacitance for each frequency added.

This curve shows the frequency characteristics when recommended capacitance for each frequency added.

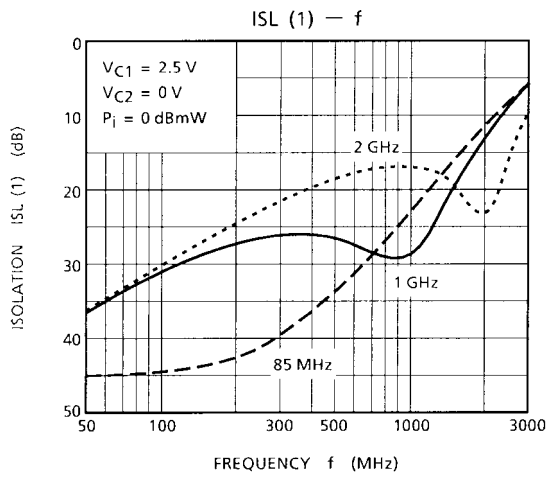

This curve shows the frequency characteristics when recommended capacitance for each frequency added.

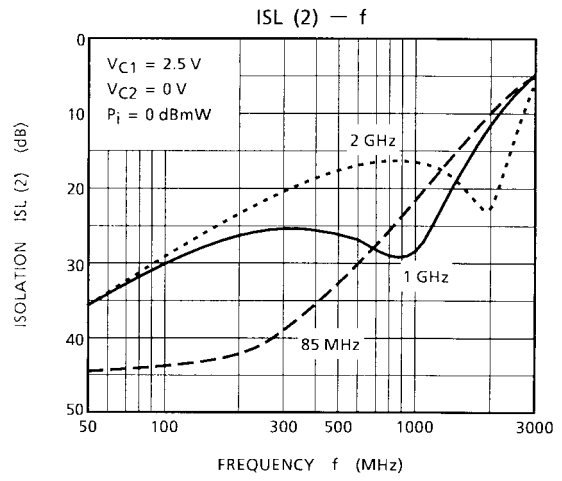

This curve shows the frequency characteristics when recommended capacitance for each frequency added.

Package Dimensions

SSOP6-P-0.95

Unit : mm

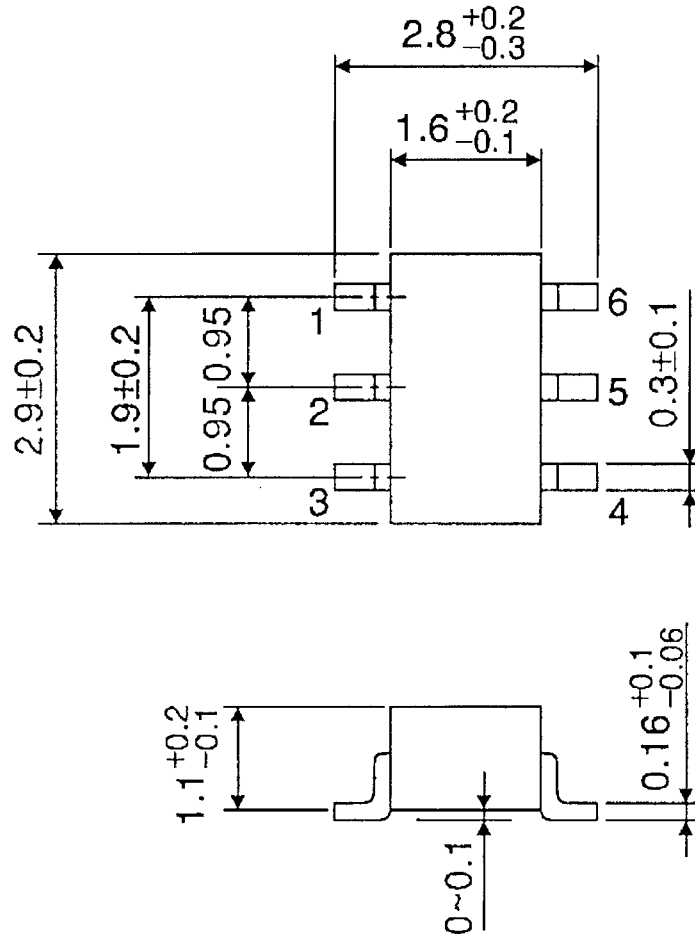

Weight : 0.014 g (Typ.)

RESTRICTIONS ON PRODUCT USE

020704EBC

- TOSHIBA is continually working to improve the quality and reliability of its products. Nevertheless, semiconductor devices in general can malfunction or fail due to their inherent electrical sensitivity and vulnerability to physical stress. It is the responsibility of the buyer, when utilizing TOSHIBA products, to comply with the standards of safety in making a safe design for the entire system, and to avoid situations in which a malfunction or failure of such TOSHIBA products could cause loss of human life, bodily injury or damage to property.
In developing your designs, please ensure that TOSHIBA products are used within specified operating ranges as set forth in the most recent TOSHIBA products specifications. Also, please keep in mind the precautions and conditions set forth in the "Handling Guide for Semiconductor Devices," or "TOSHIBA Semiconductor Reliability Handbook" etc..
- The TOSHIBA products listed in this document are intended for usage in general electronics applications (computer, personal equipment, office equipment, measuring equipment, industrial robotics, domestic appliances, etc.). These TOSHIBA products are neither intended nor warranted for usage in equipment that requires extraordinarily high quality and/or reliability or a malfunction or failure of which may cause loss of human life or bodily injury ("Unintended Usage"). Unintended Usage include atomic energy control instruments, airplane or spaceship instruments, transportation instruments, traffic signal instruments, combustion control instruments, medical instruments, all types of safety devices, etc.. Unintended Usage of TOSHIBA products listed in this document shall be made at the customer's own risk.
- Gallium (GaAs) Arsenide is a substance used in the products described in this document. GaAs dust or vapor is harmful to the human body. Do not break, cut, crush or dissolve chemically.
- The products described in this document are subject to the foreign exchange and foreign trade laws.
- The information contained herein is presented only as a guide for the applications of our products. No responsibility is assumed by TOSHIBA CORPORATION for any infringements of intellectual property or other rights of the third parties which may result from its use. No license is granted by implication or otherwise under any intellectual property or other rights of TOSHIBA CORPORATION or others.
- The information contained herein is subject to change without notice.