



LC7573N, 7573NM

1/2 Duty VFD Driver for Frequency Display

Preliminary



Overview

The LC7573N and LC7573NM are 1/2 duty VFD drivers that can be used for electronic tuning frequency display and other applications under the control of a controller. These products can directly drive VFDs with up to 38 segments.

Features

- 38 segment outputs
- Noise reduction circuits are built into the output drivers.
- Serial data input supports CCB* format communications with the system controller.
- Switching between digital and analog dimmers under serial data control
- High generality since display data is displayed without the intervention of a decoder
- All segments can be turned off with the $\overline{\text{BLK}}$ pin

- CCB is a trademark of SANYO ELECTRIC CO., LTD.
- CCB is SANYO's original bus format and all the bus addresses are controlled by SANYO.

Package Dimensions

unit: mm

3061-DIP30S

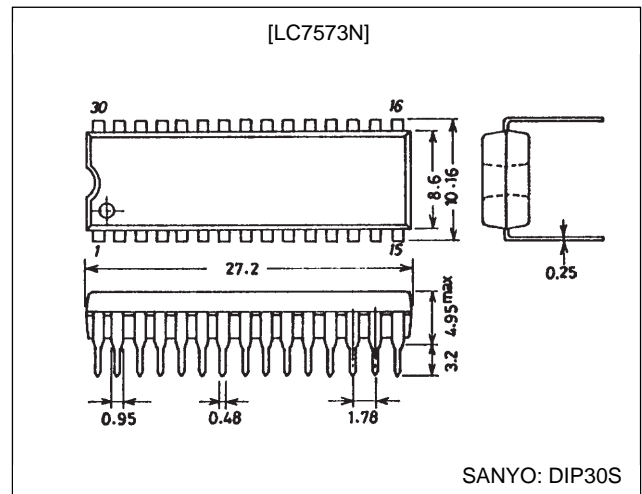

SANYO: DIP30S

unit: mm

3073A-MFP30S

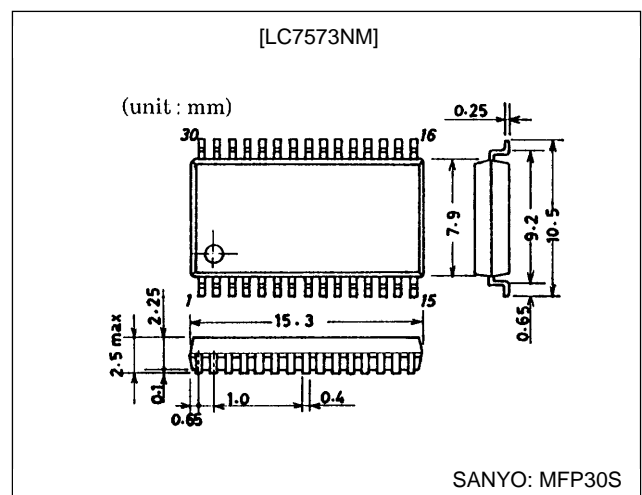

SANYO: MFP30S

Pin Assignment

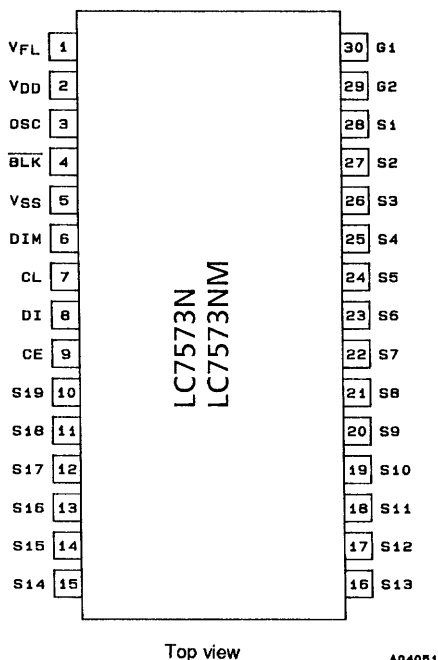

Top view

A040B1

LC7573N, 7573NM

Specifications

Absolute Maximum Ratings at $T_a = 25^\circ\text{C}$, $V_{SS} = 0\text{ V}$

Parameter	Symbol	Conditions	Ratings	Unit
Maximum supply voltage	$V_{DD\text{ max}}$	V_{DD}	-0.3 to +6.5	V
	$V_{FL\text{ max}}$	V_{FL}	-0.3 to +21.0	V
Input voltage	V_{IN1}	DI, CL, CE, $\overline{\text{BLK}}$, DIM	-0.3 to +6.5	V
	V_{IN2}	OSC	-0.3 to $V_{DD} + 0.3$	V
Output voltage	V_{OUT1}	S1 to S19, G1, G2	-0.3 to $V_{FL} + 0.3$	V
	V_{OUT2}	OSC	-0.3 to $V_{DD} + 0.3$	V
Output current	I_{OUT1}	S1 to S19	5	mA
	I_{OUT2}	G1, G2	30	mA
Allowable power dissipation	$P_d\text{ max}$	$T_a = 85^\circ\text{C}$	150	mW
Operating temperature	T_{opr}		-40 to +85	$^\circ\text{C}$
Storage temperature	T_{stg}		-50 to +125	$^\circ\text{C}$

Allowable Operating Ranges at $T_a = -40$ to $+85^\circ\text{C}$, $V_{DD} = 4.5$ to 5.5 V , $V_{SS} = 0\text{ V}$

Parameter	Symbol	Conditions	min	typ	max	Unit
Supply voltage	V_{DD}	V_{DD}	4.5	5.0	5.5	V
	V_{FL}	V_{FL}	8	12	18	V
Input high level voltage	V_{IH}	DI, CL, CE, $\overline{\text{BLK}}$	$0.8 V_{DD}$		5.5	V
Input low level voltage	V_{IL}	DI, CL, CE, $\overline{\text{BLK}}$	0		$0.2 V_{DD}$	V
Guaranteed oscillator range	f_{OSC}	OSC	0.4	1.6	3.0	MHz
Recommended external resistance	R_{OSC}	OSC		12		k Ω
Recommended external capacitance	C_{OSC}	OSC		50		pF
Low level clock pulse width	$t_{\phi L}$	CL: Figure 1	0.5			μs
High level clock pulse width	$t_{\phi H}$	CL: Figure 1	0.5			μs
Data setup time	t_{ds}	DI, CL: Figure 1	0.5			μs
Data hold time	t_{dh}	DI, CL: Figure 1	0.5			μs
CE wait time	t_{cp}	CE, CL: Figure 1	0.5			μs
CE setup time	t_{cs}	CE, CL: Figure 1	0.5			μs
CE hold time	t_{ch}	CE, CL: Figure 1	0.5			μs
BLK switching time	t_c	BLK, CE: Figure 3	10			μs
Input voltage range	V_{IN}	DIM	0		+5.5	V

Electrical Characteristics in the Allowable Operating Ranges

Parameter	Symbol	Conditions	min	typ	max	Unit
Input high level current	I_{IH}	DI, CL, CE, $\overline{\text{BLK}}$, DIM: $V_I = 5.5\text{ V}$			5	μA
Input low level current	I_{IL}	DI, CL, CE, $\overline{\text{BLK}}$, DIM: $V_I = 0\text{ V}$	-5			μA
Output high level voltage	V_{OH1}	S1 to S19: $I_O = 2\text{ mA}$	$V_{FL} - 0.6$			V
	V_{OH2}	G1, G2: $I_O = 25\text{ mA}$	$V_{FL} - 0.6$			V
Output low level voltage	V_{OL}	S1 to S19, G1, G2: $I_O = -5\text{ }\mu\text{A}$, $T_a = 25^\circ\text{C}$	0.125	0.25	0.5	V
Oscillator frequency	f_{OSC}	$R_{OSC} = 12\text{ k}\Omega$, $C_{OSC} = 50\text{ pF}$		1.6		MHz
Hysteresis voltage	V_H	DI, CL, CE, $\overline{\text{BLK}}$	0.5			V
A/D converter linearity error	Err	DIM	-1/2		+1/2	LSB
Current drain	I_{DD}	Outputs open: $f_{OSC} = 1.6\text{ MHz}$			5	mA

LC7573N, 7573NM

1. When CL is stopped at the low level

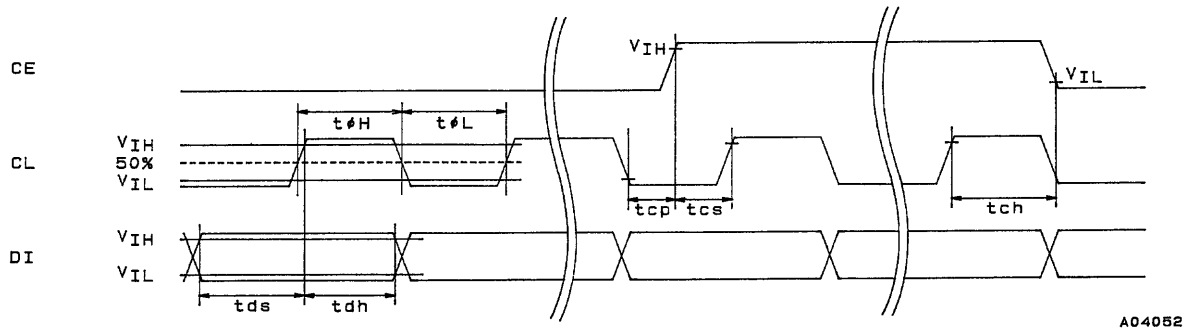

2. When CL is stopped at the high level

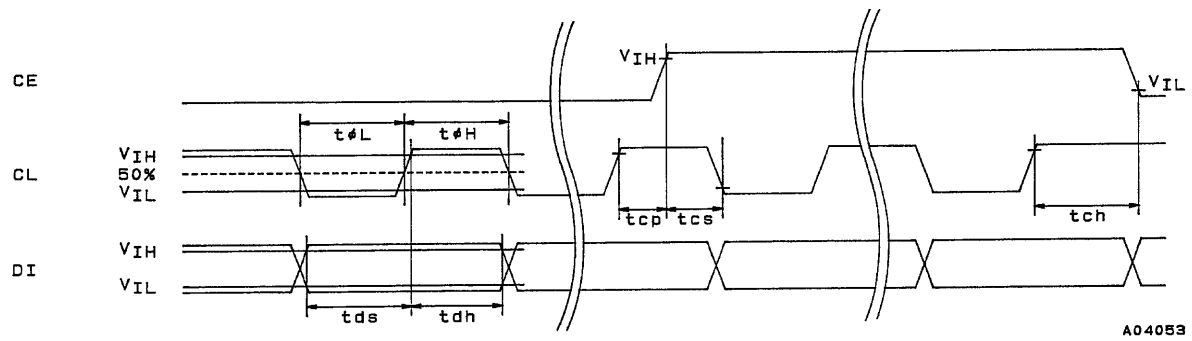
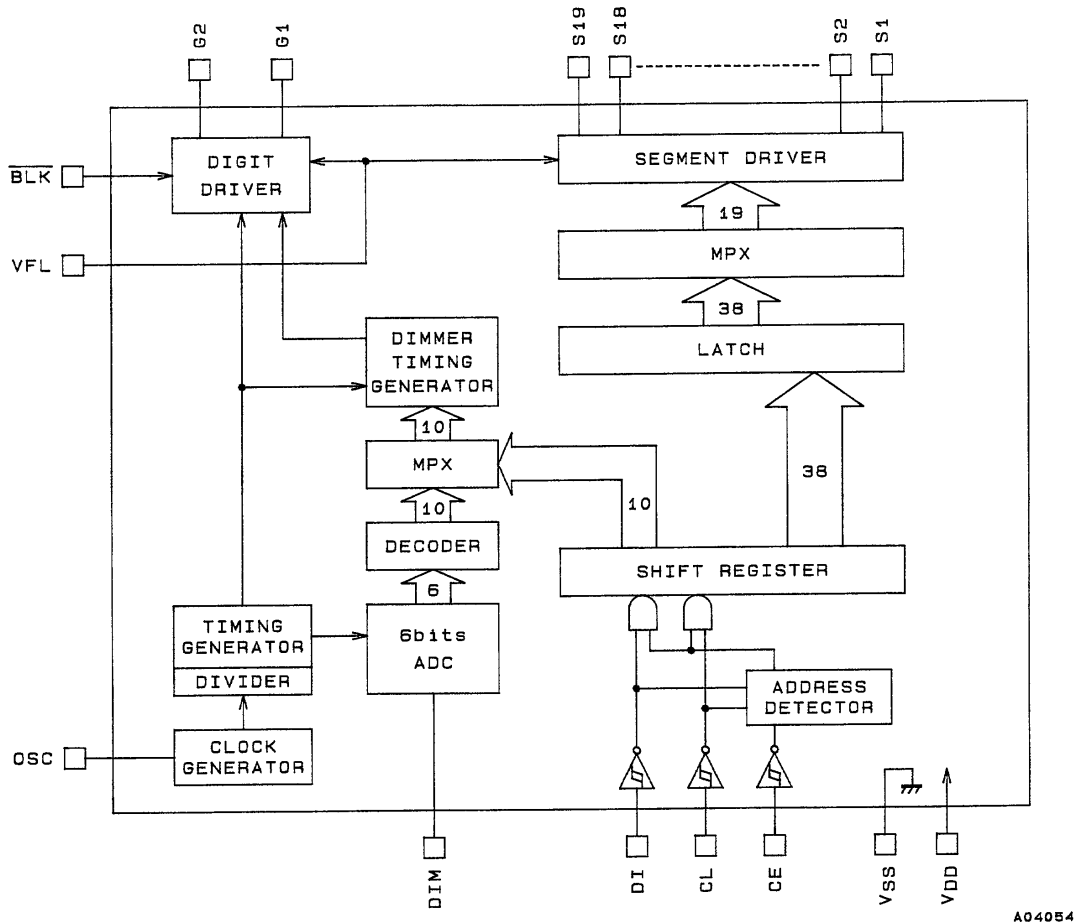

Figure 1

Block Diagram



LC7573N, 7573NM

Pin Functions

Pin No.	Pin	I/O	Function	Handling when unused	
1	V _{FL}	—	Driver block power supply. A voltage of between 8.0 and 18.0 V must be supplied.	—	
2	V _{DD}	—	Logic block power supply. A voltage of between 4.5 and 5.5 V must be supplied.	—	
5	V _{SS}	—	Ground. Must be connected to the system ground.	—	
3	OSC	I/O	Oscillator connection. An oscillator circuit is formed by connecting an external resistor and capacitor to this pin.	V _{DD}	
4	BLK	I	Display off control input BLK = low (V _{SS}): Display off (G1 and G2 = low) BLK = high (V _{DD}): Display on Note that serial data can be transferred while the display is turned off.	GND	
7	CL	I	Serial data transfer inputs. These pins must be connected to the system controller.	GND	
8	DI				CL: synchronization clock DI: transfer data CE: chip enable
9	CE				
6	DIM	I	When the analog dimmer is selected, the analog voltage applied to this pin controls the duty of the G1 and G2 digit output pins. Since a 6-bit A/D converter is applied to this analog voltage and that result is input to a decoder that provides a built-in dimmer curve, the relationship between the analog voltage and the duty can be specified as a mask program. Note that $63/96 \cdot V_{DD}$ is the full-scale level for the 6-bit A/D converter.	GND	
30, 29	G1, G2	O	Digit outputs. The frame frequency f_O is ($f_{OSC}/4096$) Hz	Open	
28 to 10	S1 to S19	O	Segment outputs for displaying the display data transferred by serial data input.	Open	

Serial Data Transfer Format

- When CL is stopped at the low level

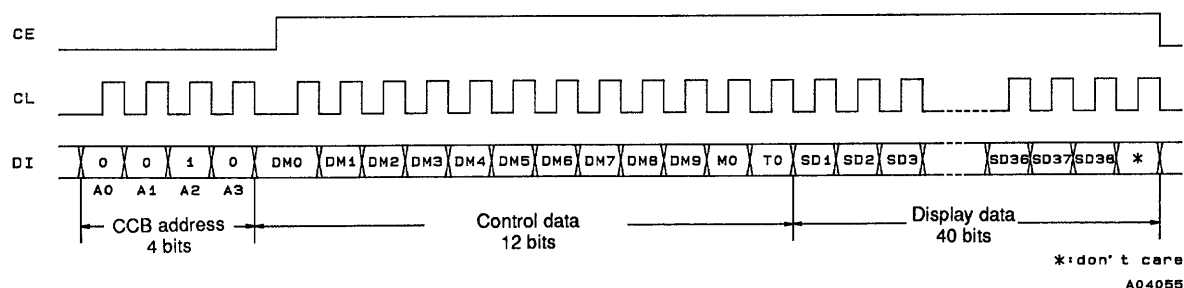

- When CL is stopped at the high level

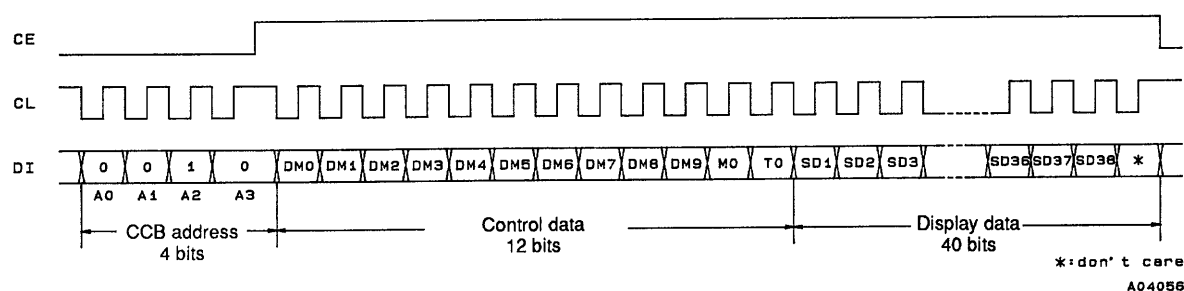

Figure 2

LC7573N, 7573NM

CCB address: Transfer 0010_B, as shown in Figure 2.

M0: Digital/analog dimmer selection data
M0 = 0Digital dimmer
M0 = 1Analog dimmer

DM0 to DM9: Dimmer data
This data controls the duty of the G1 and G2 digit output pins when the digital dimmer is selected. This data consists of 10 bits, of which DM0 is the LSB. Note that display intensity can be adjusted by controlling the duty of the G1 and G2 digit output pins. (The DM0 to DM9 dimmer data is ignored when the analog dimmer is selected.)

SD1 to SD38: Display data
SD1 to SD19.....Display data for the G1 digit output pin
SD20 to SD38.....Display data for the G2 digit output pin
SDn (n = 1 to 38) = 1.....Display on
SDn (n = 1 to 38) = 0.....Display off

T0: Test data
The T0 bit must be set to 0.

Serial Data Format

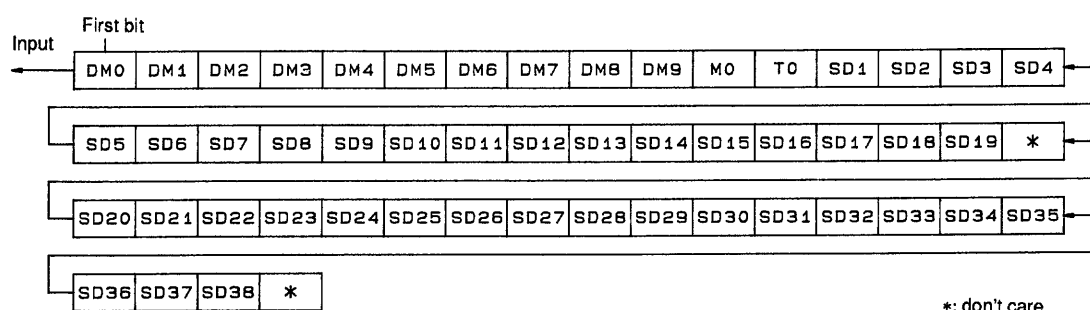

A04057

Correspondence between Display Data (SD1 to SD38) and Segment Output Pins

Segment output pin	G1	G2
S1	SD1	SD20
S2	SD2	SD21
S3	SD3	SD22
S4	SD4	SD23
S5	SD5	SD24
S6	SD6	SD25
S7	SD7	SD26
S8	SD8	SD27
S9	SD9	SD28
S10	SD10	SD29
S11	SD11	SD30
S12	SD12	SD31
S13	SD13	SD32
S14	SD14	SD33
S15	SD15	SD34
S16	SD16	SD35
S17	SD17	SD36
S18	SD18	SD37
S19	SD19	SD38

Example: Segment output pin S11 is controlled as follows:

Display data		Segment output pin S11 state
SD11	SD30	
0	0	The segments corresponding to both the G1 and G2 digit output pins are off.
0	1	The segment corresponding to the G2 digit output pin is on.
1	0	The segment corresponding to the G1 digit output pin is on.
1	1	The segments corresponding to both the G1 and G2 digit output pins are on.

BLK and the Display Control

Since the LSI internal data (SD1 to SD38 and the control data) is undefined when power is first applied, the display is off (G1 and G2 = low) by setting the $\overline{\text{BLK}}$ pin low at the same time as power is applied. Then, meaningless display at power on can be prevented by transferring all 56 bits of serial data from the controller while the display is off and setting $\overline{\text{BLK}}$ pin high after the transfer completes. (See Figure 3.)

Power Supply Sequence

The following sequences must be observed when power is turned on and off. (See Figure 3.)

- Power on: Logic block power supply (V_{DD}) on → Driver block power supply (V_{FL}) on
- Power off: Driver block power supply (V_{FL}) off → Logic block power supply (V_{DD}) off

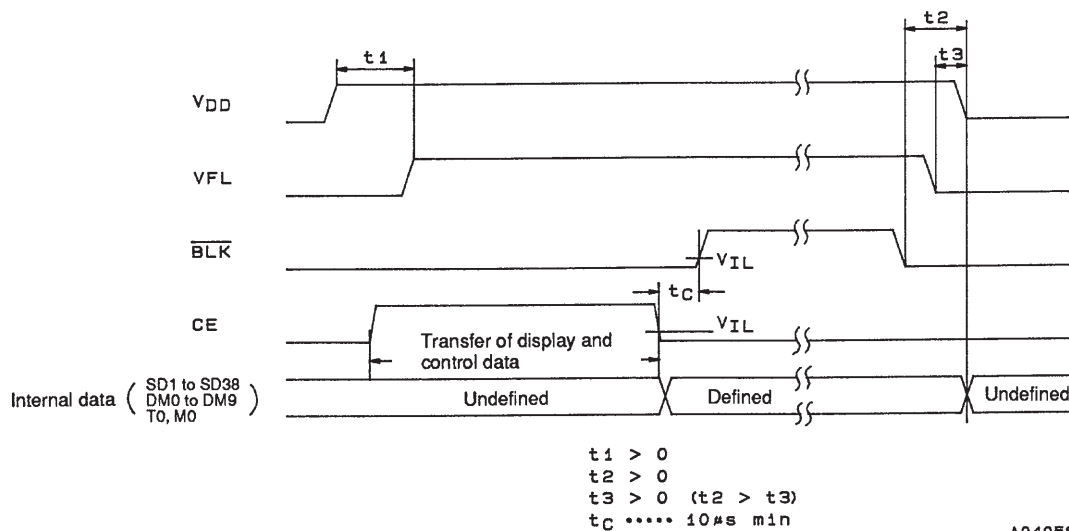
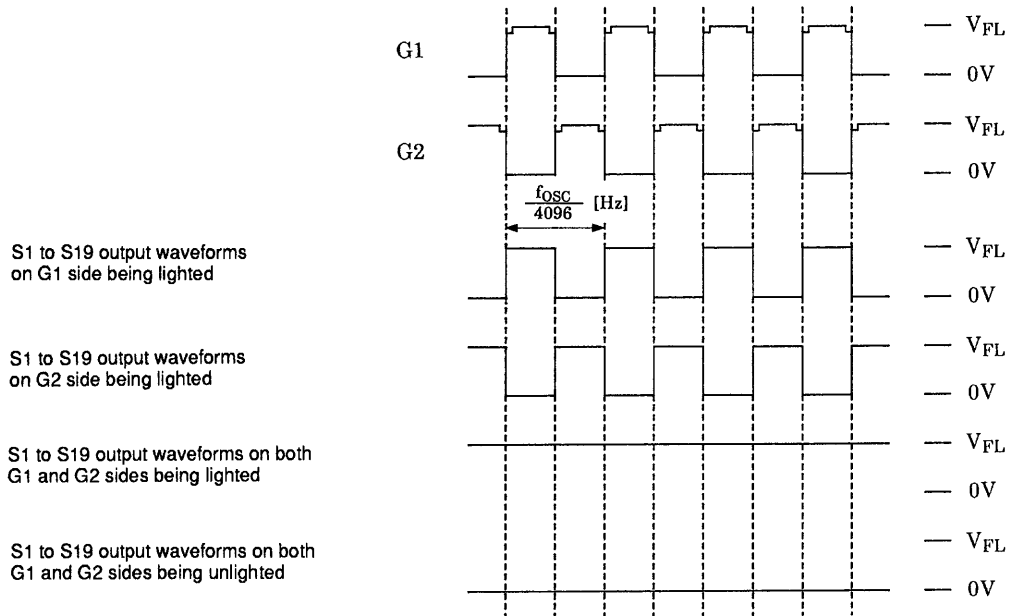

Figure 3

Output Waveforms (S1 to S19)



A04059

Relation between Segment and Digit Outputs

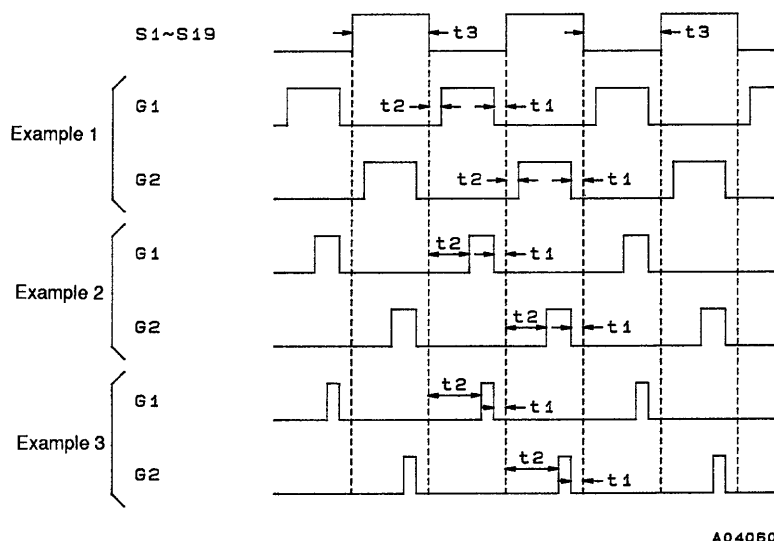

Figure 4

Descriptions

1. Consider the examples shown in Figure 4, where data is set up so that the segment outputs S1 to S19 output a low level on the G1 digit output timing and a high level on the G2 digit output timing. (Here, the G2 side being lighted)
2. The digit output G1 and G2 waveforms in Example 1 are output when the 10 bits of dimmer data (DM0 to DM9) are set to 3FE_H. The relation between t1 and the oscillator frequency f_{OSC} is:

$$t1 = 2/f_{OSC}$$

For example, if f_{OSC} = 1.6 [MHz], then

$$t1 = 2/1.6 [MHz] = 1.25 [\mu s].$$

Note that t1 and t2 are the same period in Example 1.

3. The digit output G1 and G2 waveforms in Example 2 are those when the dimmer data (DM0 to DM9) are set to a smaller value. Although the time t1, which is from the point where digit output falls to segment output changes, does not change, the time t2, which is from the point where segment output changes to the time the digit output rises, becomes longer. When the dimmer data (DM0 to DM9) are set to 0FF_H and f_{OSC} is 1.6 [MHz], then the frame frequency f_O is:

$$\begin{aligned} f_O &= 1/(t3 \times 2) \\ &= f_{OSC}/4096 \\ &= 391 [Hz], \end{aligned}$$

and,

$$t3 = 1.28 [ms].$$

Therefore,

$$t2 = \frac{(1.28 [ms] - 1.25 [\mu s] \times 2) \times (3FF_H - 0FF_H)}{1023} = 0.96 [ms].$$

4. When the dimmer data (DM0 to DM9) are set to an even smaller value, the time t2, which is from the point where segment output changes to the time the digit output rises, becomes even longer, as in Example 3. Note that t1 does not change here, either.

Sample Application Circuit

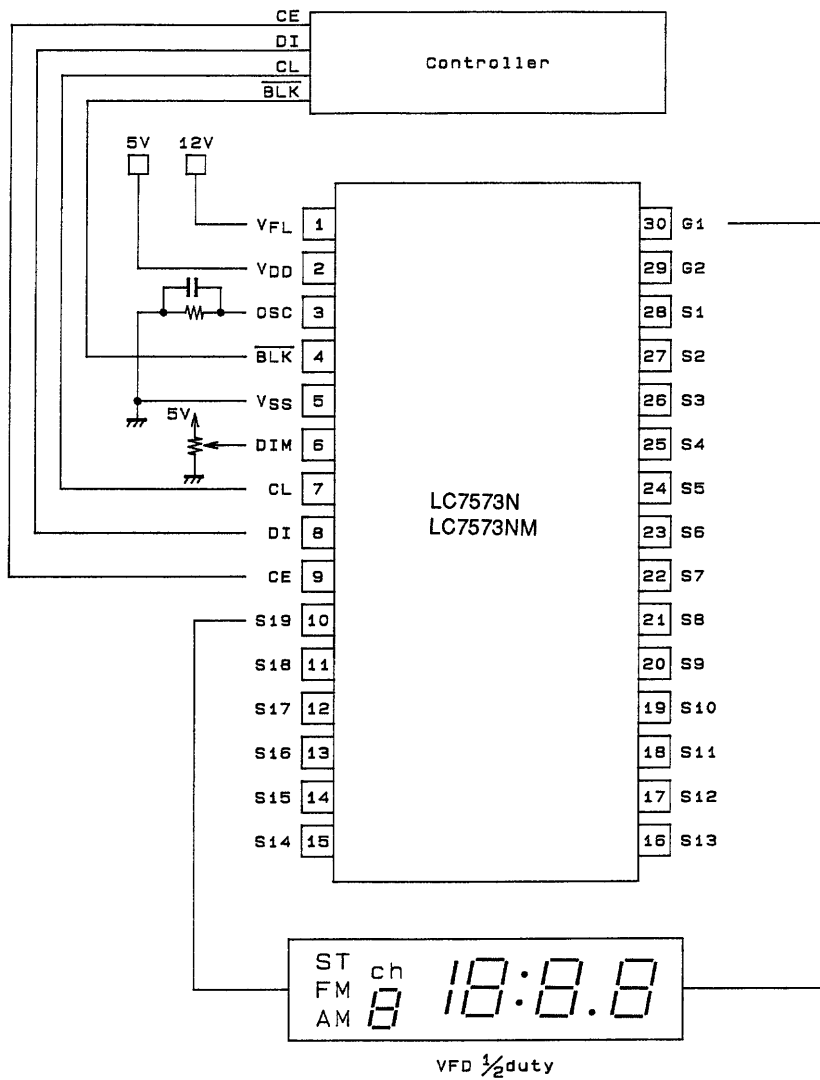

A04061

Usage Notes

- Notes on the segment and digit waveforms

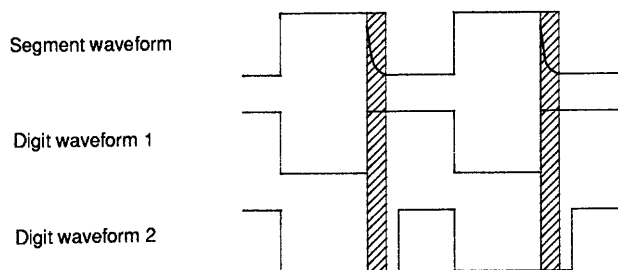

A04062

Figure 5

LC7573N, 7573NM

The segment waveform is distorted by the VFD panel used and the wiring, and furthermore, in the case of being used with essentially no dimming as in the digit waveform 1, as shown in Figure 5, the VFD panel glow dimly. By carefully considering the segment waveform, it can be seen that this problem can be resolved by applying an adequate amount of dimming, as shown in Digit waveform 2. When f_{OSC} is 1.6 [MHz], we recommend using 10 bits of dimmer data in the range 000_H to $3E0_H$.

- No products described or contained herein are intended for use in surgical implants, life-support systems, aerospace equipment, nuclear power control systems, vehicles, disaster/crime-prevention equipment and the like, the failure of which may directly or indirectly cause injury, death or property loss.
- Anyone purchasing any products described or contained herein for an above-mentioned use shall:
 - ① Accept full responsibility and indemnify and defend SANYO ELECTRIC CO., LTD., its affiliates, subsidiaries and distributors and all their officers and employees, jointly and severally, against any and all claims and litigation and all damages, cost and expenses associated with such use:
 - ② Not impose any responsibility for any fault or negligence which may be cited in any such claim or litigation on SANYO ELECTRIC CO., LTD., its affiliates, subsidiaries and distributors or any of their officers and employees jointly or severally.
- Information (including circuit diagrams and circuit parameters) herein is for example only; it is not guaranteed for volume production. SANYO believes information herein is accurate and reliable, but no guarantees are made or implied regarding its use or any infringements of intellectual property rights or other rights of third parties.

This catalog provides information as of October, 1995. Specifications and information herein are subject to change without notice.