

MGF0904A

L, S BAND POWER GaAs FET

DESCRIPTION

The MGF0904A, GaAs FET with an N-channel schottky gate, is designed for use in UHF band amplifiers.

FEATURES

- High output power
 $P_o = 28\text{dBm (TYP.) @ } f = 1.65\text{GHz, } P_{in} = 15\text{dBm}$
- High power gain
 $G_p = 13.0\text{dB (TYP.) @ } f = 1.65\text{GHz, } P_{in} = 15\text{dBm}$
- High power added efficiency
 $\eta_{add} = 40\% \text{ (TYP.) @ } f = 1.65\text{GHz, } P_{in} = 15\text{dBm}$

APPLICATION

For UHF Band power amplifiers

QUALITY GRADE

- GG

RECOMMENDED BIAS CONDITIONS

- $V_{DS} = 8\text{V}$
- $I_D = 200\text{mA}$
- $R_g = 500\Omega$
- Refer to Bias Procedure

OUTLINE DRAWING

Unit: millimeters (inches)

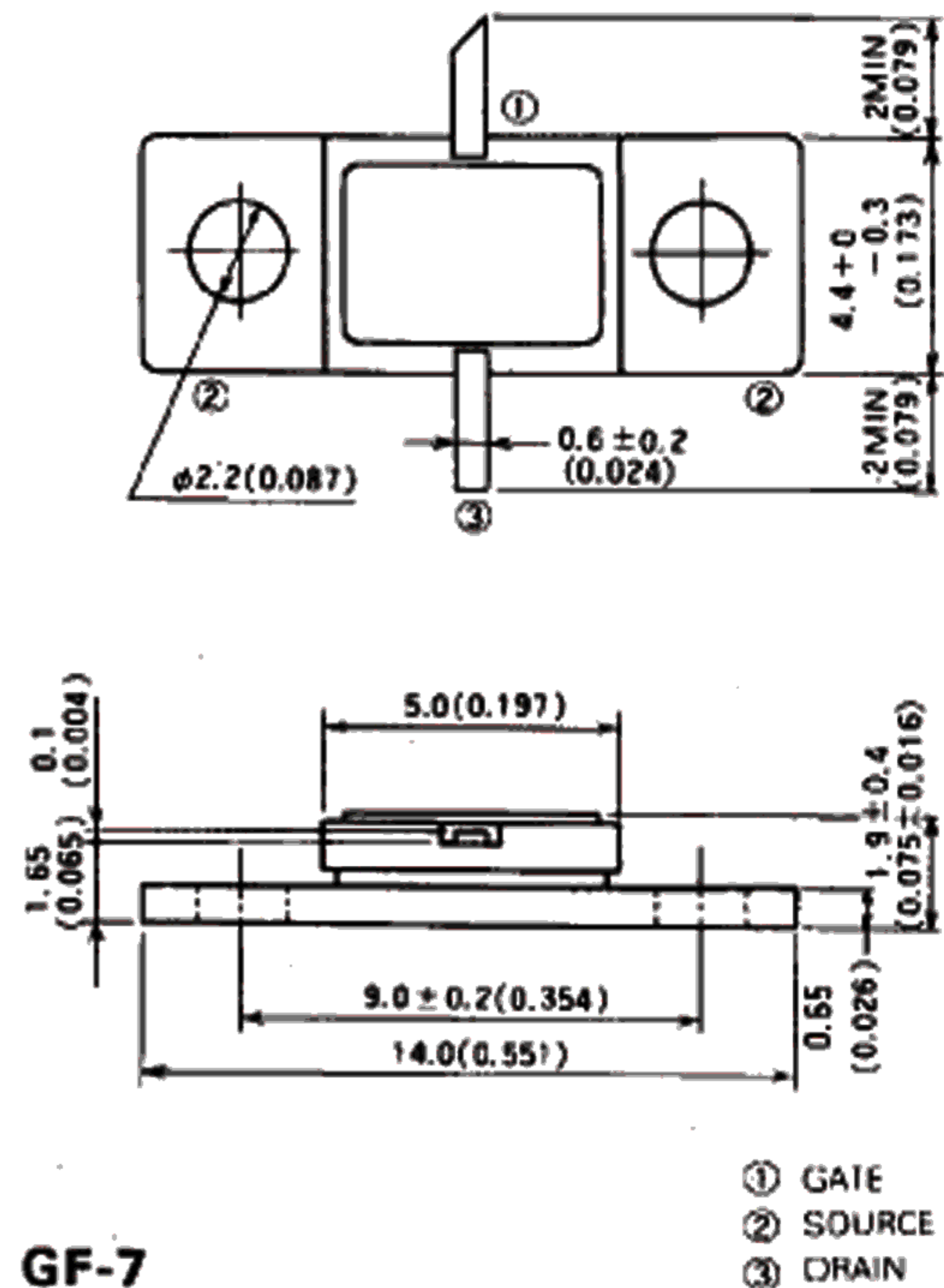

ABSOLUTE MAXIMUM RATINGS ($T_a = 25^\circ\text{C}$)

Symbol	Parameter	Ratings	Unit
V_{GS0}	Gate to source voltage	-17	V
V_{GD0}	Gate to drain voltage	-17	V
I_D	Drain current	800	mA
I_{GR}	Reverse gate current	-2.5	mA
I_{GF}	Forward gate current	5.4	mA
P_T	Total power dissipation *1	3.75	W
T_{ch}	Channel temperature	175	$^\circ\text{C}$
T_{stg}	Storage temperature	-65 ~ +175	$^\circ\text{C}$

*1: $T_c = 25^\circ\text{C}$

ELECTRICAL CHARACTERISTICS ($T_a = 25^\circ\text{C}$)

Symbol	Parameter	Test conditions	Limits			Unit
			Min	Typ	Max	
I_{DSS}	Saturated drain current	$V_{DS} = 3\text{V, } V_{GS} = 0\text{V}$	400	550	800	mA
$V_{GS(off)}$	Gate to source cut-off voltage	$V_{DS} = 3\text{V, } I_D = 2.5\text{mA}$	-1	-3	-5	V
g_m	Transconductance	$V_{DS} = 3\text{V, } I_D = 300\text{mA}$	120	200	—	mS
P_o	Output power	$V_{DS} = 8\text{V, } I_D = 200\text{mA, } f = 1.65\text{GHz, } P_{in} = 15\text{dBm}$	26	28	—	dBm
η_{add}	Power added efficiency		—	40	—	%
$R_{th(ch-c)}$	Thermal resistance *1	ΔV_f method	—	—	40	$^\circ\text{C/W}$
$R_{th(ch-a)}$	Thermal resistance (channel to ambient temperature)	ΔV_f method	—	—	100	$^\circ\text{C/W}$

*1: Channel to case

L, S BAND POWER GaAs FET

TYPICAL CHARACTERISTICS

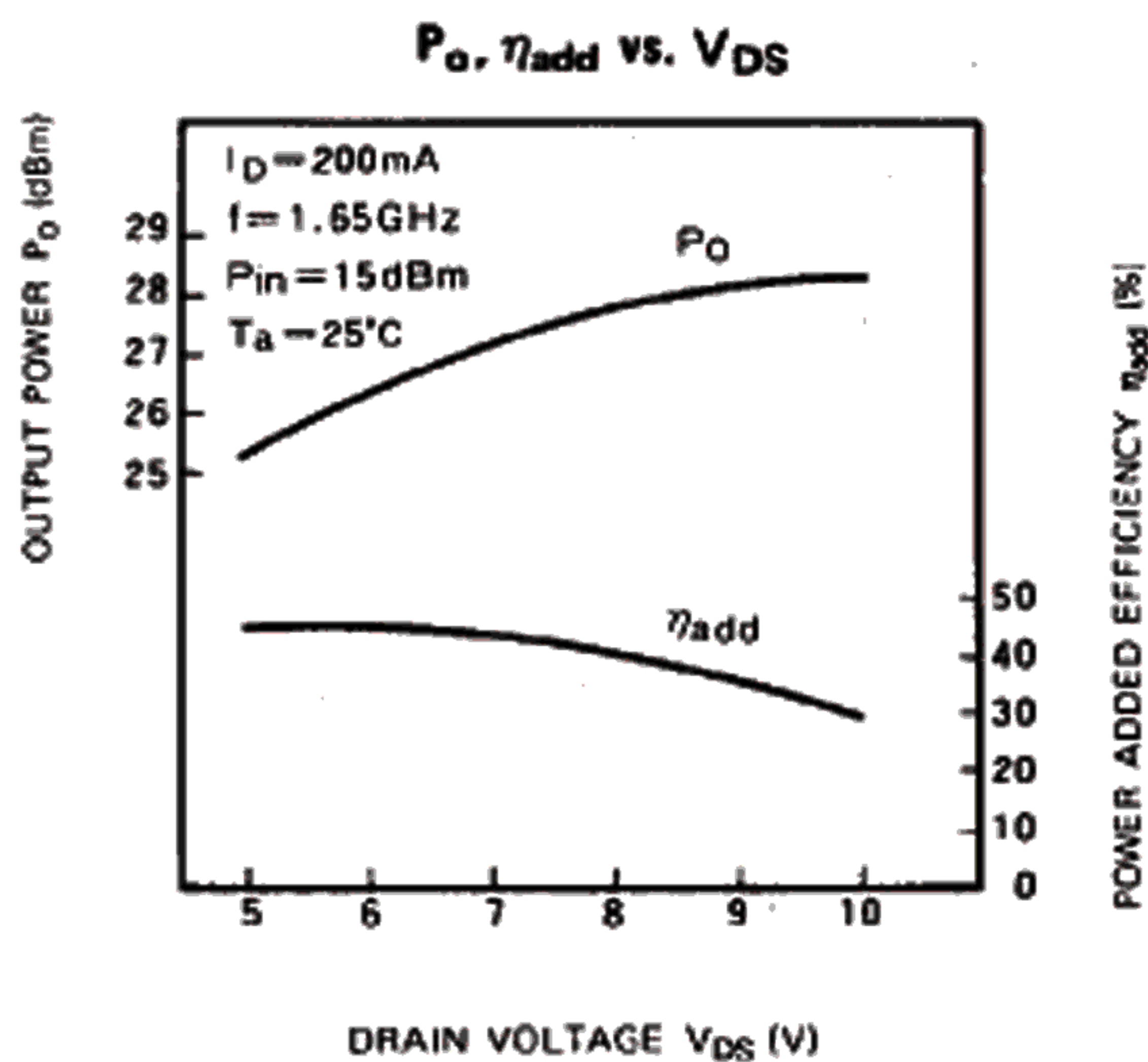
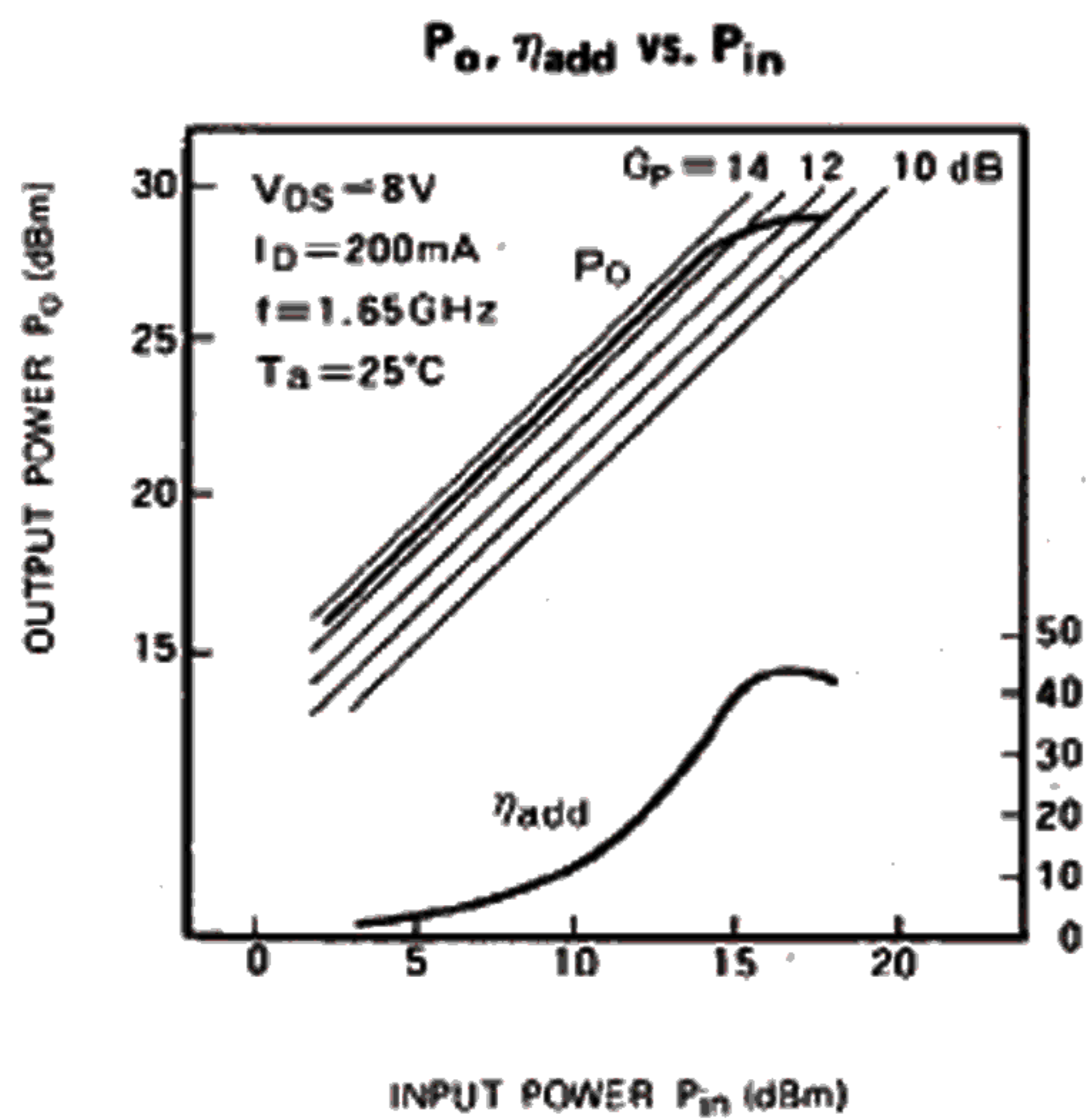
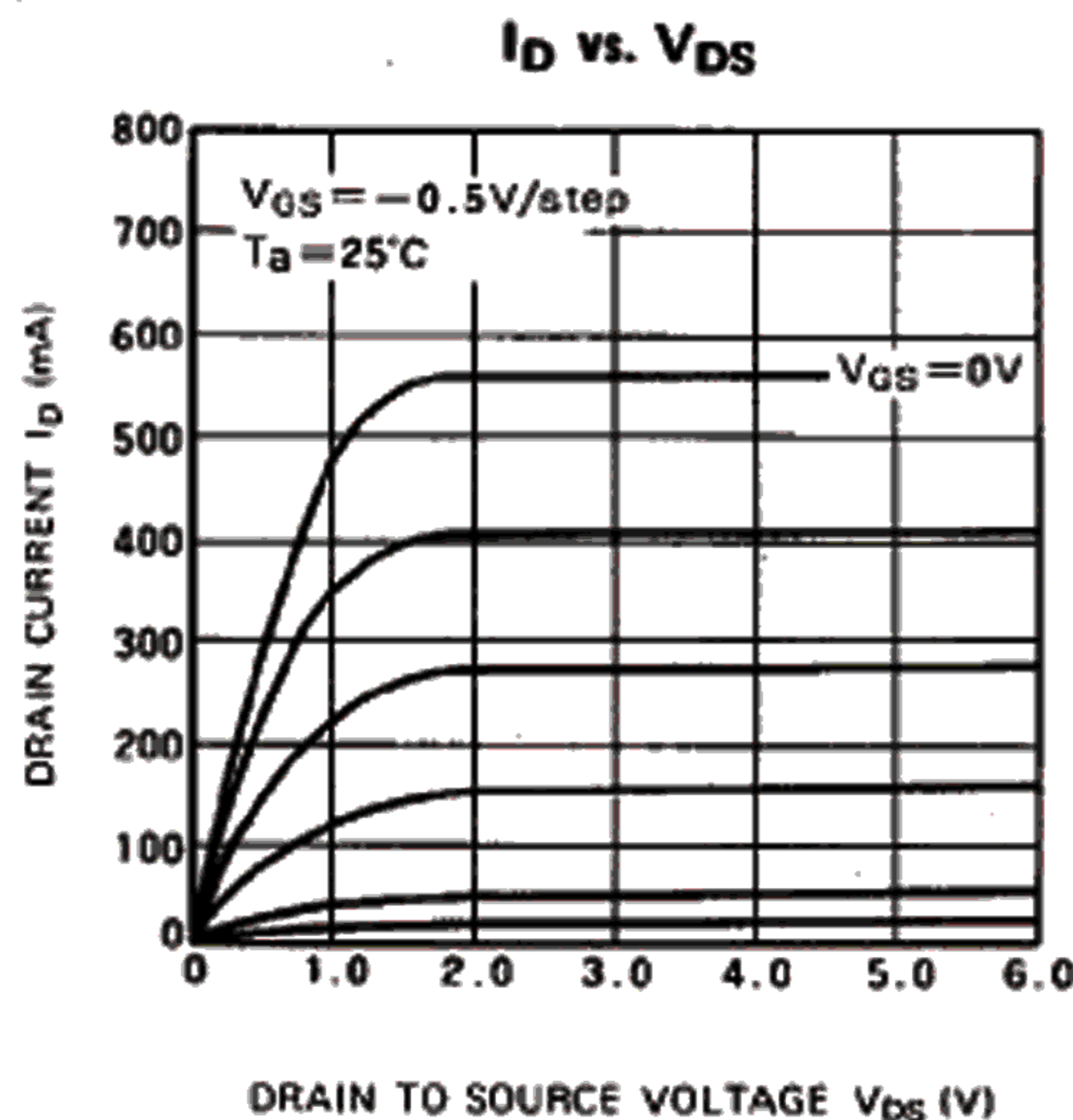
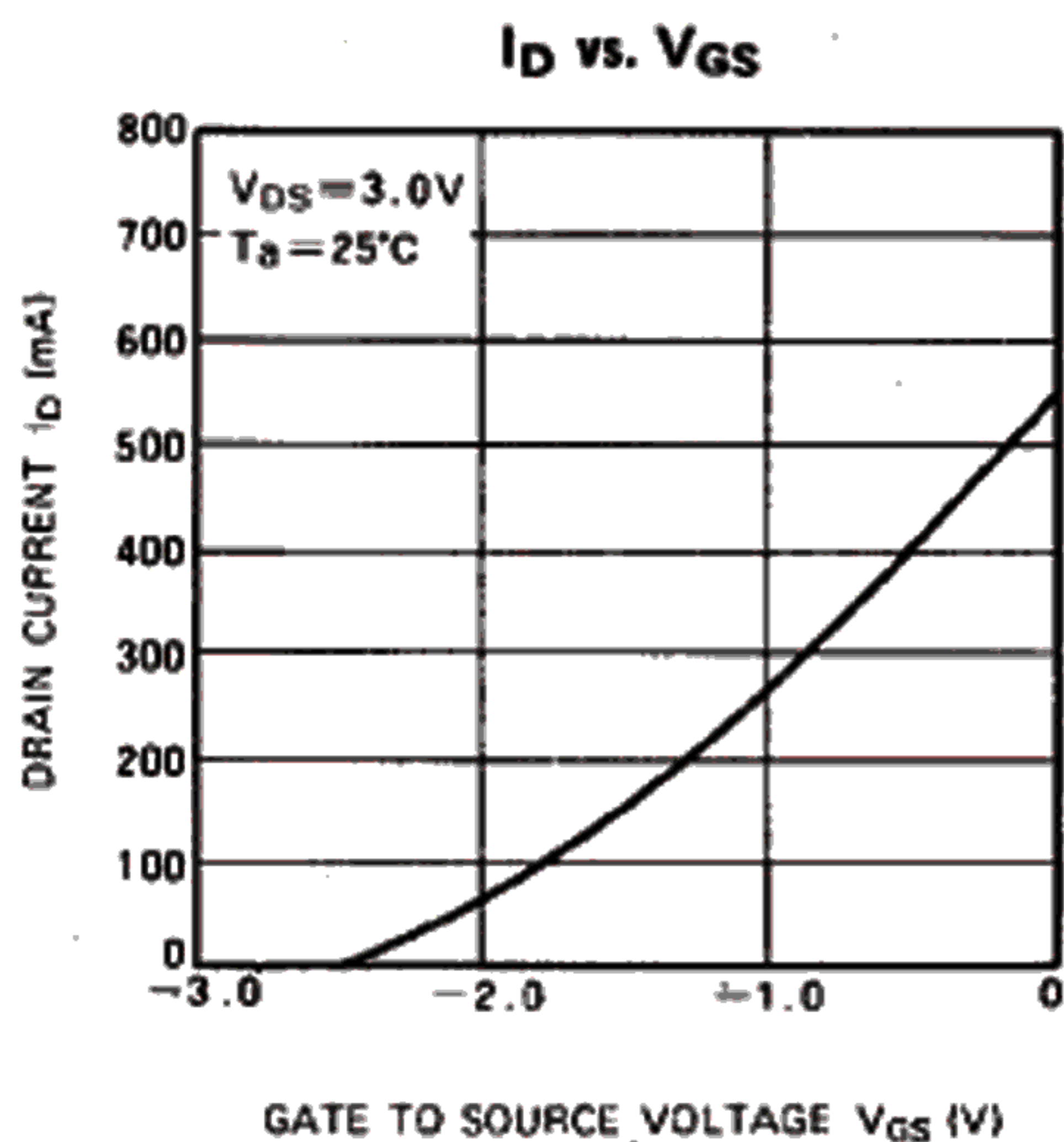

MGF0904A

L, S BAND POWER GaAs FET

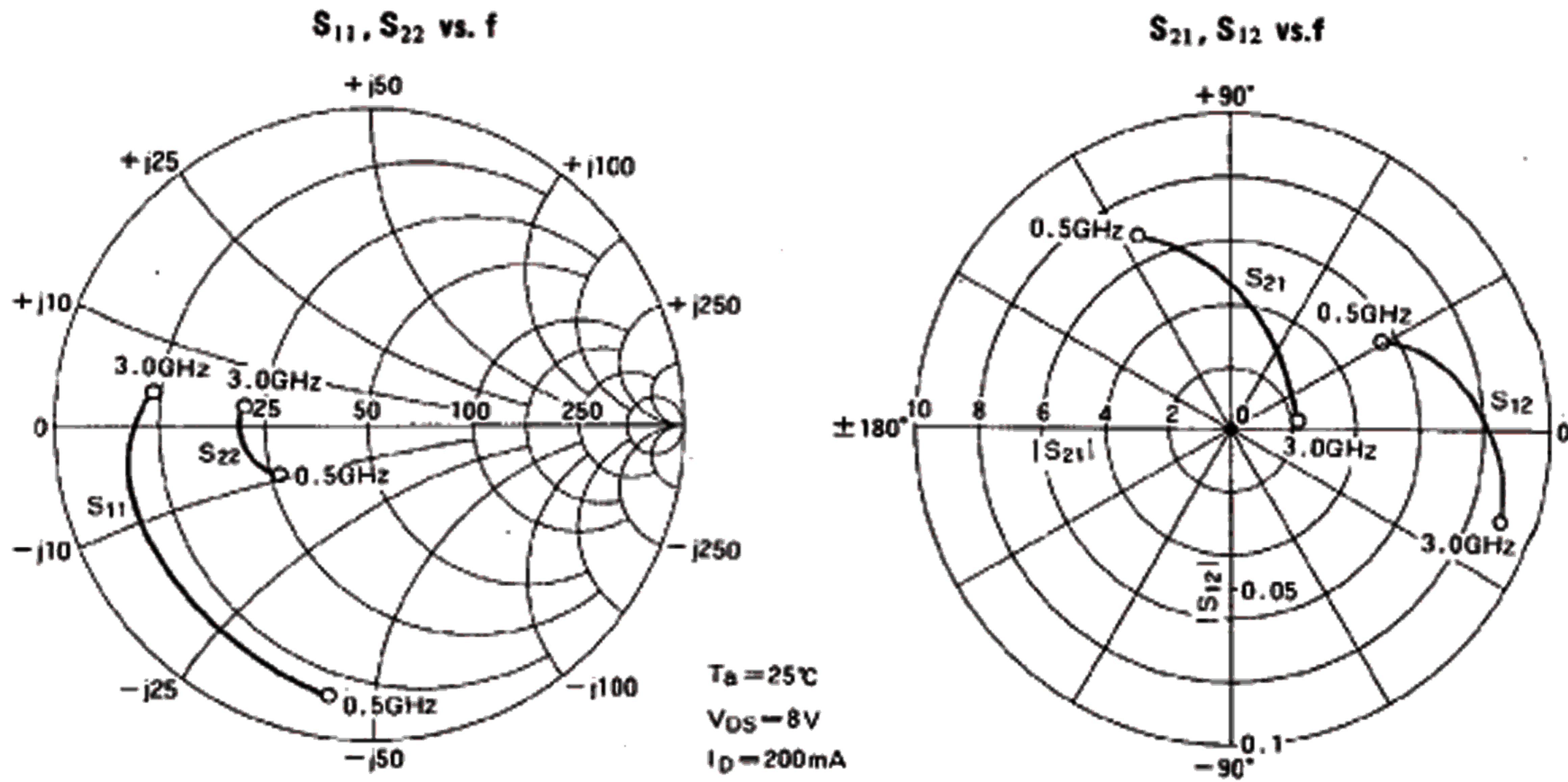

S PARAMETERS ($T_a = 25^\circ\text{C}$, $V_{DS} = 8\text{V}$, $I_D = 200\text{mA}$)

f (GHz)	S_{11}		S_{21}		S_{12}		S_{22}		K	MSG/MAG dB
	Magn.	Angle (deg.)	Magn.	Angle (deg.)	Magn.	Angle (deg.)	Magn.	Angle (deg.)		
0.5	0.851	-99.0	6.855	116.0	0.055	31.0	0.338	-149.0	0.277	21.0
1.0	0.801	-138.0	4.265	89.0	0.064	22.5	0.368	-162.0	0.521	18.2
1.5	0.788	-161.5	3.192	71.0	0.072	13.0	0.390	-173.3	0.655	16.5
2.0	0.740	-177.0	2.544	52.0	0.079	4.0	0.409	-178.0	0.847	15.1
2.5	0.713	176.5	2.180	30.0	0.085	-7.0	0.411	177.0	0.940	14.1
3.0	0.670	171.5	2.040	9.0	0.091	-18.0	0.402	172.0	1.070	11.9