

Electro-optical Characteristics

T-41-63

(Ta=25°C)

Parameter	Symbol	Conditions	MIN.	TYP.	MAX.	Unit
*2Collector current	PT370	*3 Ev=100lx, Vce=5V (PT372: Vce=2V)	100	300	900	μA
	PT371		100	—	900	
	PT372		3.0	—	23	mA
Collector dark current	PT370/PT371	Ec=0, Vce=20V	—	2.0	100	nA
	PT372	Ec=0, Vce=10V	—	—	1.0	μA
Collector-emitter saturation voltage	PT370/PT371	*3Ec=10mW/cm², Ic=0.5mA	—	0.2	0.4	V
	PT372	*3Ec=1mW/cm², Ic=2.5mA	—	0.8	1.0	
Peak sensitivity wavelength	λp	—	—	800	—	nm
Response time (Rise)	PT370/PT371	Vcc=20V, Ic=1mA, RL=1kΩ	—	10	40	μs
	PT372	Vce=2V, Ic=10mA, RL=100Ω	—	100	400	μs
Response time (Fall)	PT370/PT371	Vcc=20V, Ic=1mA, RL=1kΩ	—	8	35	μs
	PT372	Vce=2V, Ic=10mA, RL=100Ω	—	100	400	μs
Half intensity angle	PT370	—	—	±45	—	deg.
	PT371		—	±65	—	
	PT372		—	±70	—	

*2 The collector current (Ic) shall be classified into the ranks as follows before delivery.

Rank	Collector current Ic		
	PT370 (μA)	PT371 (μA)	PT372 (mA)
A	100~216	100~244	3.0~9.66
B	170~320	192~463	7.14~23.0
C	252~533	363~900	—
D	419~900	—	—

*3 Ev, Ec: Illuminance, irradiance by CIE standard light source A (tungsten lamp)

Fig. 1 Collector Power Dissipation vs. Ambient Temperature

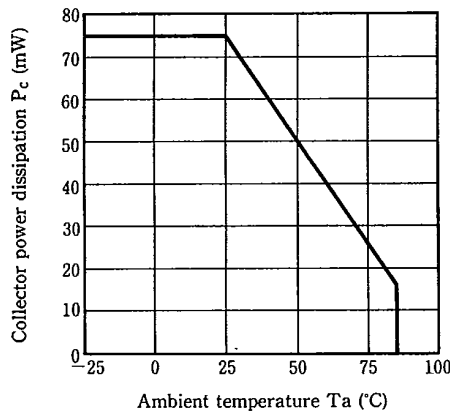
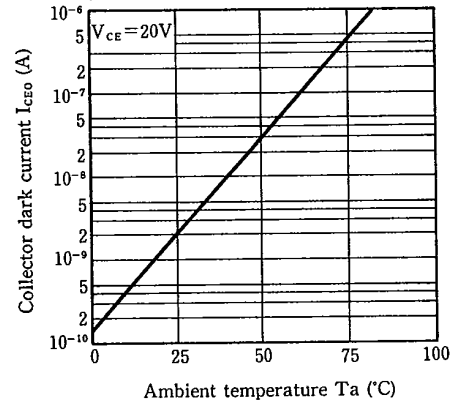

Fig. 2 Collector Dark Current vs. Ambient Temperature (PT370/PT371)



T-41-61

T-41-63

Fig. 3 Collector Dark Current vs. Ambient Temperature (PT372)

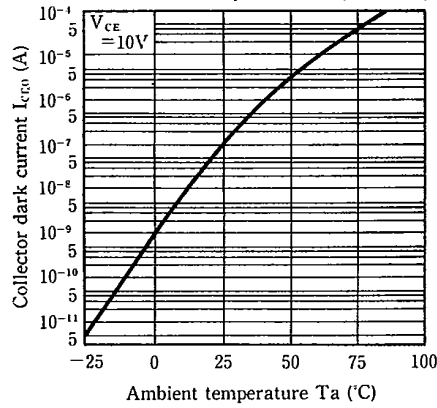

Fig. 4 Relative Collector Current vs. Ambient Temperature (PT370/PT371)

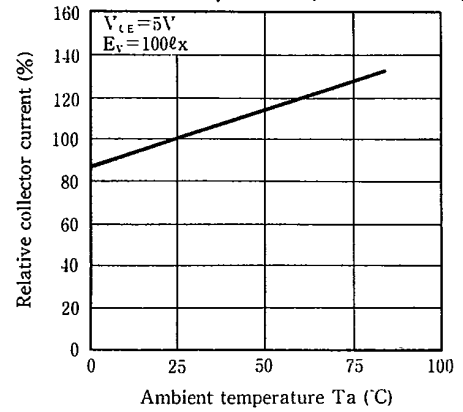

Fig. 5 Relative Collector Current vs. Ambient Temperature (PT372)

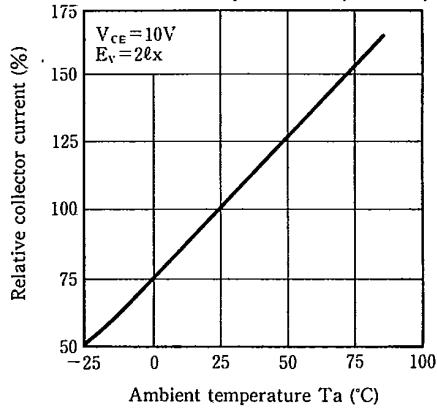

Fig. 6 Collector Current vs. Irradiance (PT370/PT371)

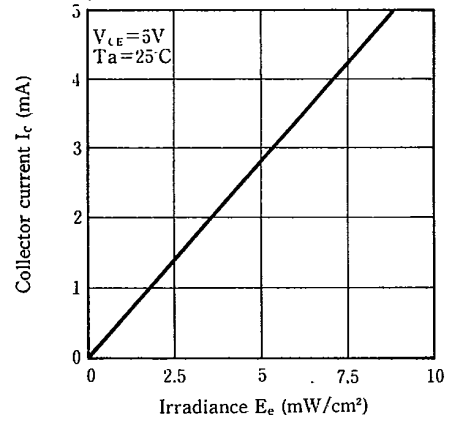

Fig. 7 Collector Current vs. Irradiance (PT372)

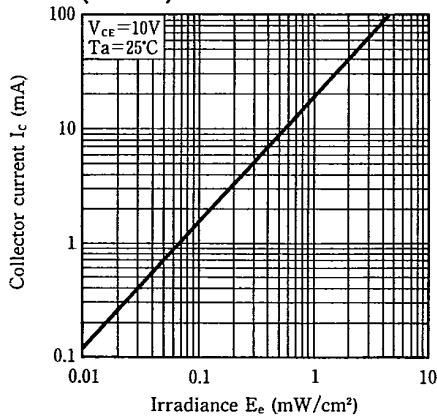

Fig. 8 Collector Current vs. Collector-emitter Voltage (PT370)

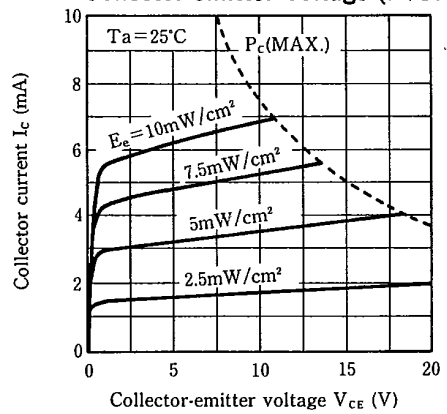

Fig. 9 Collector Current vs. Collector-emitter Voltage (PT371)

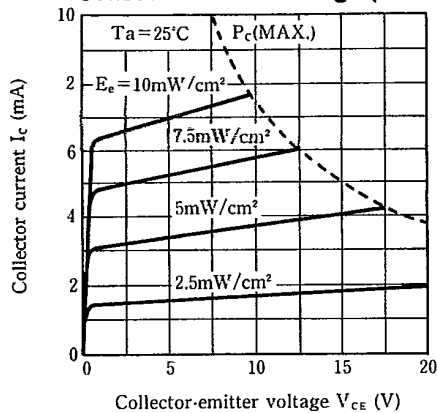

Fig. 10 Collector Current vs. Collector-emitter Voltage (PT372)

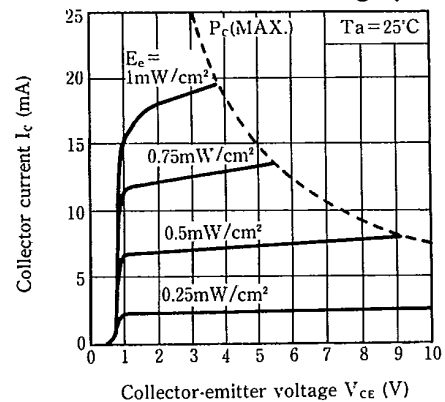

Fig. 11 Spectral Sensitivity

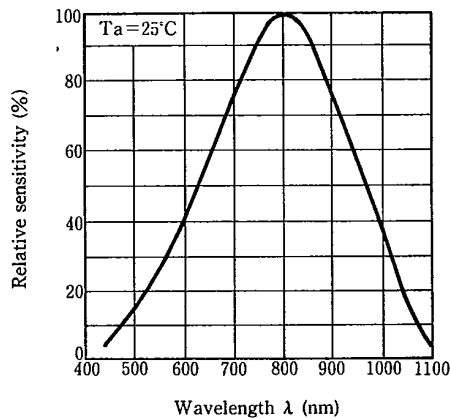

Fig. 12 Response Time vs. Load Resistance (PT370/PT371)

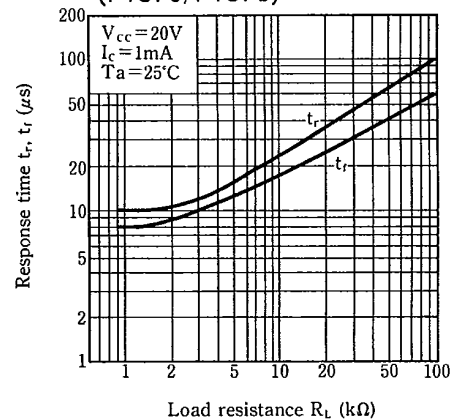
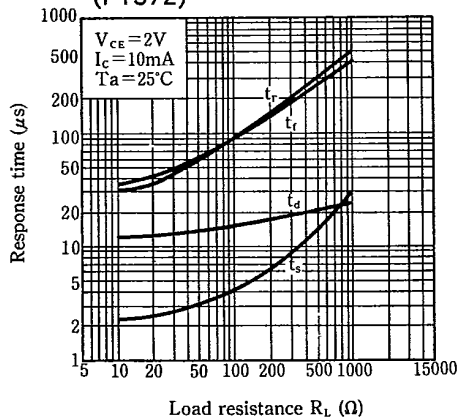
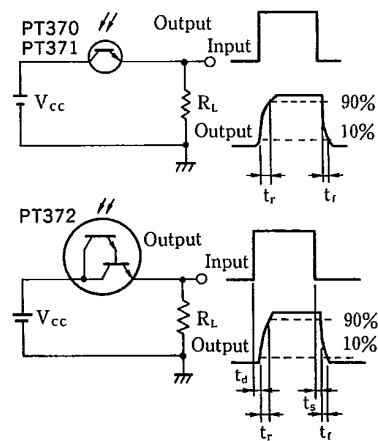

Fig. 13 Response Time vs. Load Resistance (PT372)



Test Circuit for Response Time



5

Fig. 14 Sensitivity Diagram (PT370)
($T_a = 25^\circ\text{C}$)

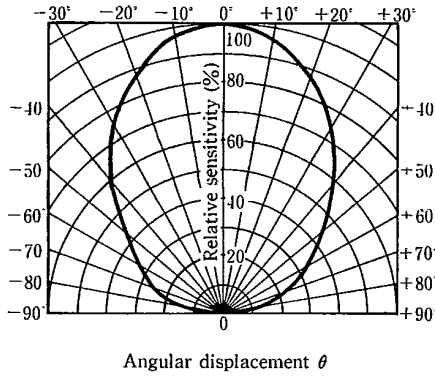

Fig. 15 Sensitivity Diagram (PT371)
($T_a = 25^\circ\text{C}$)

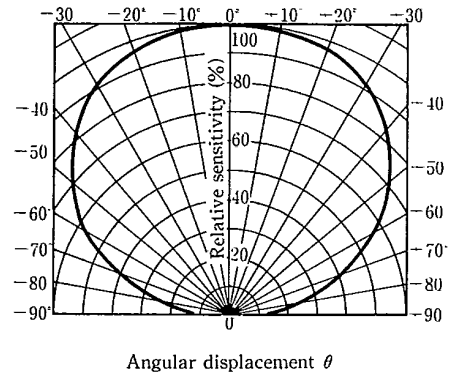

Fig. 16 Sensitivity Diagram (PT372)
($T_a = 25^\circ\text{C}$)

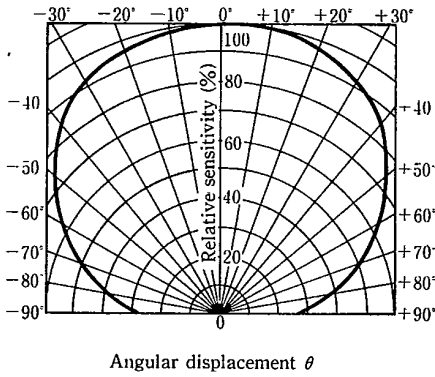

Fig. 17 Collector-emitter Saturation Voltage vs. Irradiance (PT370)

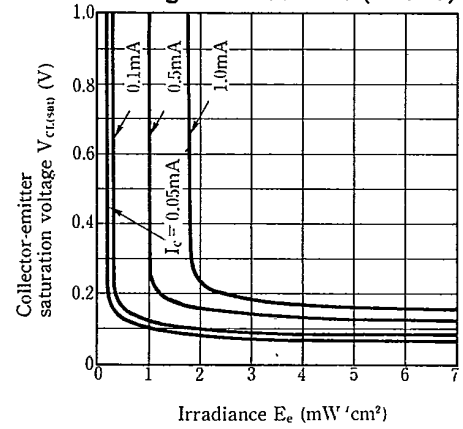

Fig. 18 Collector-emitter Saturation Voltage vs. Irradiance (PT371)

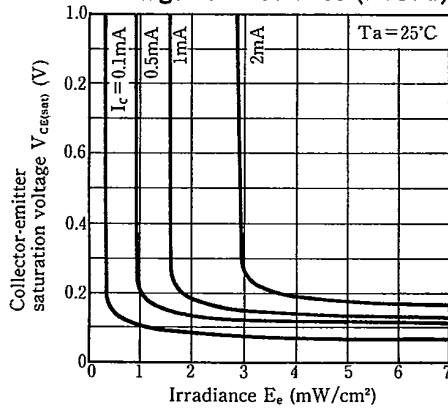

Fig. 19 Collector-emitter Saturation Voltage vs. Irradiance (PT372)

