

FEATURES

- Provides two Rambus compatible clock outputs from 240 to 310 MHz
- Uses low cost 14.318 MHz crystal as reference for 250 MHz output
- Low Jitter, <100 ps
- Output skew <50ps
- 45/55% duty cycle
- On-chip filter requires no external components
- Eight-pin, .150" SOIC
- Operates from a single 3.3V ±10% supply
- Series resonant input crystal requires no external components

DESCRIPTION

AMCC's advanced PLL technology allows the S4505 to provide two Rambus-compatible, 250, 267, or 300 MHz clocks from a low cost 14.318 MHz crystal. Other reference crystals can be used to produce other output frequencies within the 240–310 MHz range. An external series resistor allows the output to be matched to the Rambus transmission line impedance needed for each application.

AMCC utilizes its high speed, low-jitter PLL technology developed for telecom and precision clocking applications to provide outputs which meet the low jitter and symmetrical duty cycle requirements of RAMBUS system clocks.

APPLICATIONS—RDRAM BASED

- Graphics Accelerators
- PC Memory
- Set-Top Boxes
- Games

Block Diagram

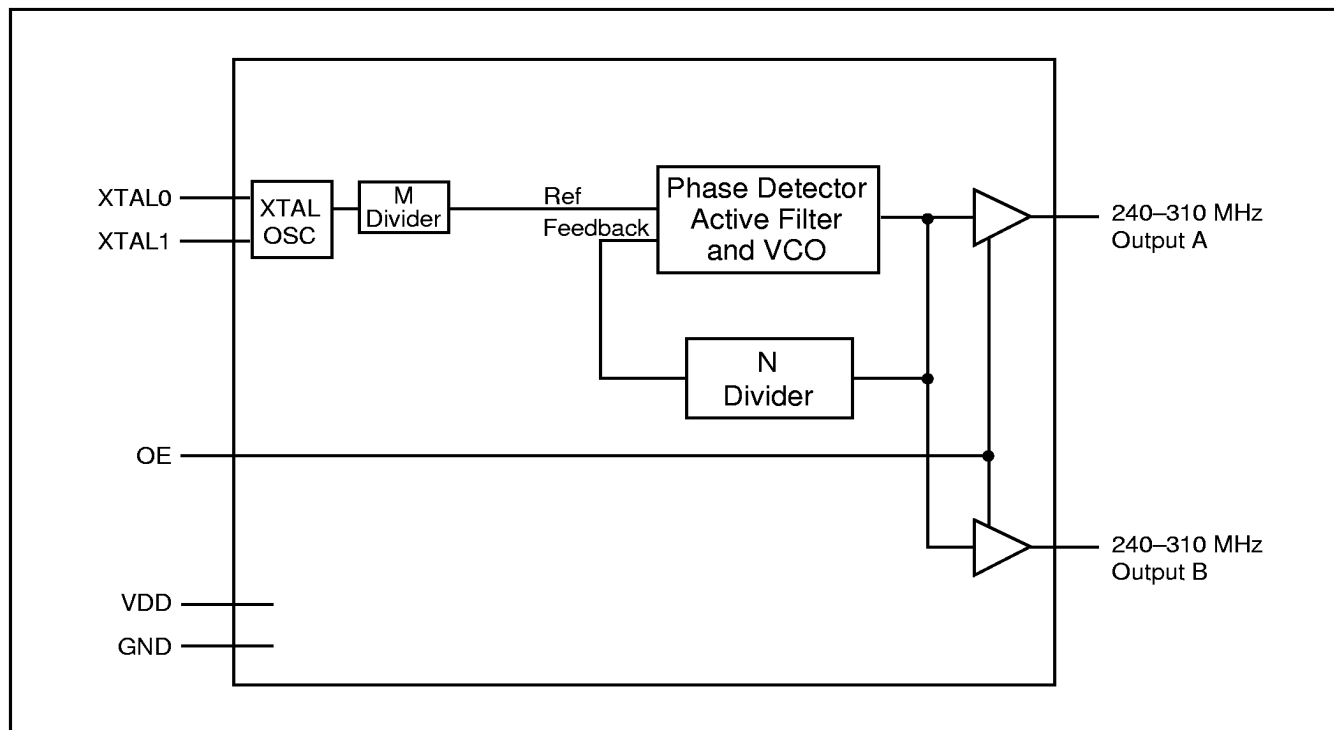

Absolute Maximum Ratings

Parameter	Description	Value	Unit
V _{DD}	Power supply vs. GND	-0.5 to +5.0	V
V _{IN}	Input voltage, and pin vs. GND	-0.5 to V _{DD} +0.5	V
Storage Temp.	Maximum temperature during storage	170°	°C

Note: Stresses greater than the absolute maximum ratings may cause permanent damage to the device. Functional operation of the device at these or any other conditions above those indicated under the normal operating conditions is not guaranteed. Exposure to absolute maximum rating conditions for extended periods may affect device reliability.

DC Specifications (T_A = 0°C – 70°C, V_{DD} = 3.3 ± 0.3V)

Parameter	Description	Conditions	Min	Max	Unit
V _{IH}	Input HIGH voltage	OE Pin	2.0		V
V _{IL}	Input LOW voltage	OE Pin		0.8	V
I _{IH}	Input HIGH current	OE Pin		50	µA
I _{IL}	Input LOW current	OE Pin – Internal pull-up		300	µA
P _D	Power Dissipation	Dynamic		440	mW

Output Characteristics

All specifications are compatible with Rambus requirements.

Symbol	Description	Comments	Min	Typ	Max	Unit
Z ₀	Line impedance	Rambus compatible	25		50	Ω
V _S	Output voltage swing	Rambus compatible	1.2		1.6	V
V _{ACO}	Output Asymmetry	Rambus compatible	-15		+15	%

AC Specifications (Operating Conditions: T_A = 0°C – 70°C, V_{DD} = 3.3V ± 0.3V)

All specifications are compatible with Rambus requirements.

Symbol	Description	Test Condition	Min	Typ	Max	Unit
F _{XTAL}	Crystal frequency		12.86	14.318	14.46	MHz
F _{OUT}	Output frequency, S4505	Typ with 14.318 MHz input ¹	240	267	310	MHz
F _{OUT}	Output frequency, S4506	Typ with 14.318 MHz input ¹	240	250	310	MHz
F _{OUT}	Output frequency, S4507	Typ with 14.318 MHz input ¹	240	300	310	MHz
T _R , T _F	Output clock rise/fall time	20% to 80%	0.2		0.5	ns
T _{DC}	Duty cycle	STD Rambus System Load	45	50	55	%
T _{JPP}	Jitter, peak-to-peak			40	100	ps
T _{PU}	Power-up time	From OFF to clocks stable			10	ms
T _{SKEW}	Output A to B skew	Equal loads		20	50	ps

1. Output frequency multiplier is 35/2 times the input crystal frequency on the S4506, 56/3 times the input crystal frequency on the S4505, and 21 times the input crystal frequency on the S4507.

8-pin SOIC

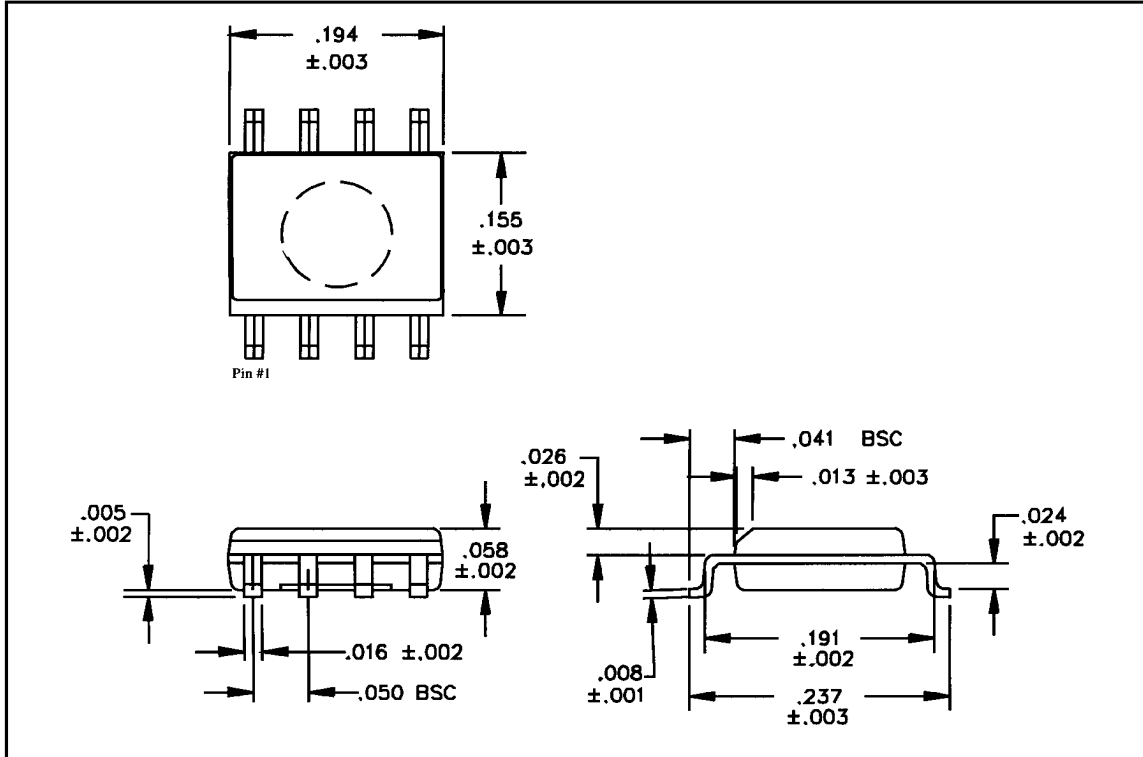

S4505/06/07 Pinout — 8-Pin SOIC

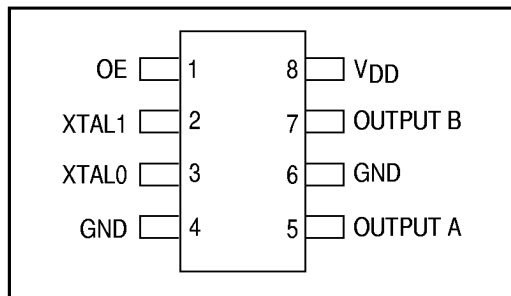

Pin Descriptions

Pin #	Description
1	Output enable, Active HIGH, Internal pull-up
2	Crystal connection — Series Resonant
3	Crystal connection — Series Resonant
4, 6	Ground
5, 7	Output A, B — 240–310 MHz clock outputs, open drain — should be terminated externally to match Rambus specifications
8	Power — 3.3V ± 10%

Ordering Information

AMCC products are available in several shipping configurations.
The order number is formed by a combination of:

- **Device Number**
- **Package Type**
- **Optional Shipping Configuration**

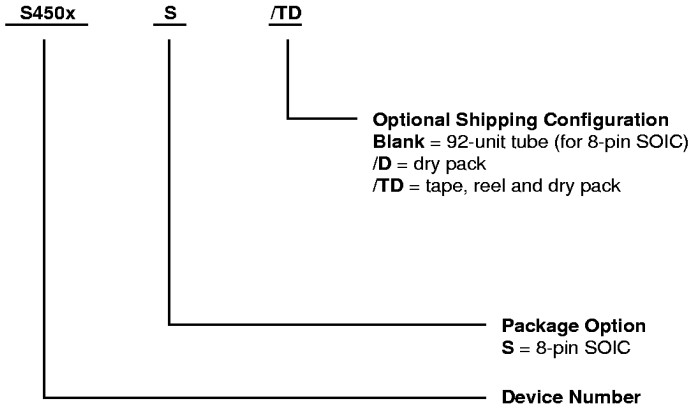

Example: S4506S/D
8-pin SOIC package, shipped dry packed in tubes.

Applied Micro Circuits Corporation • 6195 Lusk Blvd., San Diego, CA 92121

Phone: (619) 450-9333 Fax: (619) 450-9885

<http://www.amcc.com>

AMCC reserves the right to make changes to its products or to discontinue any semiconductor product or service without notice, and advises its customers to obtain the latest version of relevant information to verify, before placing orders, that the information being relied on is current.

AMCC does not assume any liability arising out of the application or use of any product or circuit described herein, neither does it convey any license under its patent rights nor the rights of others.

AMCC reserves the right to ship devices of higher grade in place of those of lower grade.

AMCC SEMICONDUCTOR PRODUCTS ARE NOT DESIGNED, INTENDED, AUTHORIZED, OR WARRANTED TO BE SUITABLE FOR USE IN LIFE-SUPPORT APPLICATIONS, DEVICES OR SYSTEMS OR OTHER CRITICAL APPLICATIONS.

AMCC is a registered trademark of Applied Micro Circuits Corporation.
Copyright © 1997 Applied Micro Circuits Corporation

March 10, 1997