

UTC TL431A LINEAR INTEGRATED CIRCUIT

PROGRAMMABLE PRECISION REFERENCE

DESCRIPTION

The UTC TL431A is a three-terminal adjustable regulator with a guaranteed thermal stability over applicable temperature ranges. The output voltage may be set to any value between V_{ref} (approximately 2.5V) and 36V with two external resistors. It provides very wide applications, including shunt regulator, series regulator, switching regulator, voltage reference and others.

FEATURES

- *Programmable output Voltage to 36V.
- *Low dynamic output impedance 0.2Ω .
- *Sink current capability of 1 to 100mA.
- *Equivalent full-range temperature coefficient of 50ppm/°C typical for operation over full rated operating temperature range.

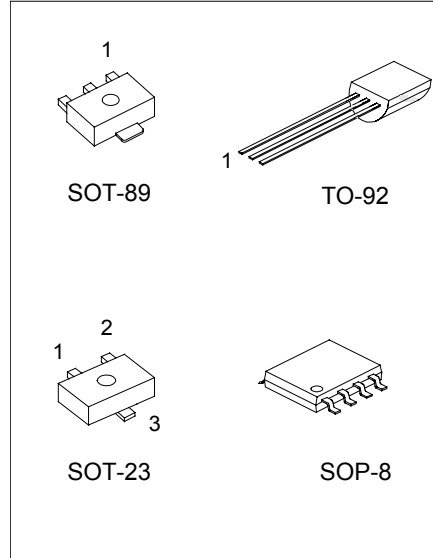

SOP-8 1: Cathode 2,3,6,7: Anode 8: Ref.
4,5: N.C.

TO-92 1: Ref; 2: Anode; 3: Cathode

SOT-89 1: Ref; 2: Anode; 3: Cathode

SOT-23 1: Cathode; 2: Ref; 3: Anode

*Pb-free plating product number: TL431AK

BLOCK DIAGRAM

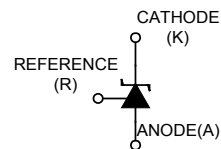
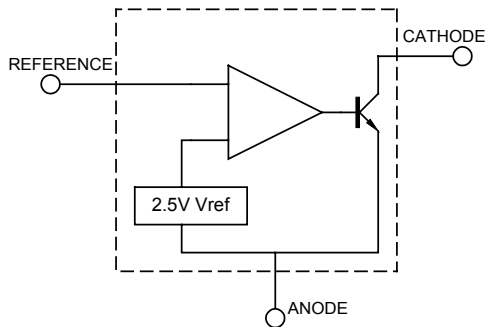

UTC TL431A LINEAR INTEGRATED CIRCUIT

ABSOLUTE MAXIMUM RATINGS (Operating temperature range applies unless otherwise specified)

PARAMETER	SYMBOL	VALUE	UNIT
Cathode Voltage	V _{KA}	37	V
Cathode Current Range(Continuous)	I _{KA}	-100 ~ +150	mA
Reference Input Current Range	I _{ref}	-0.05 ~ +10	mA
Operating Junction Temperature	T _j	150	°C
Operating Ambient Temperature	T _{opr}	-40 ~ +85	°C
Storage Temperature Temperature	T _{stg}	-65 ~ +150	°C

RECOMMENDED OPERATING CONDITIONS

PARAMETER	SYMBOL	MIN	TYP	MAX	UNIT
Cathode Voltage	V _{KA}	V _{REF}		36	V
Cathode Current	I _{KA}	1		100	mA

ELECTRICAL CHARACTERISTICS (T_a=25°C, unless otherwise specified)

PARAMETER	SYMBOL	TEST CONDITIONS	MIN	TYP	MAX	UNIT
Reference Input Voltage	V _{ref}	V _{KA} =V _{REF} , I _{KA} =10mA	2.483	2.495	2.507	V
Deviation of reference Input Voltage Over temperature(note 1)	ΔV _{ref} /ΔT	V _{KA} =V _{REF} , I _{KA} =10mA T _{MIN} ≤T _A ≤T _{MAX}		4.5	17	mV
Ratio of Change in Reference Input Voltage to the Change in Cathode Voltage	ΔV _{ref} /ΔV _{KA}	I _{KA} =10mA ΔV _{KA} =10V~V _{REF} ΔV _{KA} =36V~10V		-1.0 -0.5	-2.7 -2.0	mV/V
Reference Input Current	I _{ref}	I _{KA} =10mA, R ₁ =10kΩ, R ₂ =∞		1.5	4	μA
Deviation of Reference Input Current Over Full Temperature Range	ΔI _{ref} /ΔT	I _{KA} =10mA, R ₁ =10kΩ, R ₂ =∞ T _A =full Temperature		0.4	1.2	μA
Minimum Cathode Current for Regulation	I _{KA} (min)	V _{KA} =V _{REF}		0.45	1.0	mA
Off-State Cathode Current	I _{KA} (OFF)	V _{KA} =36V, V _{REF} =0		0.05	1.0	μA
Dynamic Impedance	Z _{KA}	V _{KA} =V _{REF} , I _{KA} =1 to 100mA f≤1.0kHz		0.15	0.5	Ω

Note: T_{MIN}=0°C, T_{MAX}=+70°C

UTC TL431A LINEAR INTEGRATED CIRCUIT

TYPICAL PERFORMANCE CHARACTERISTICS

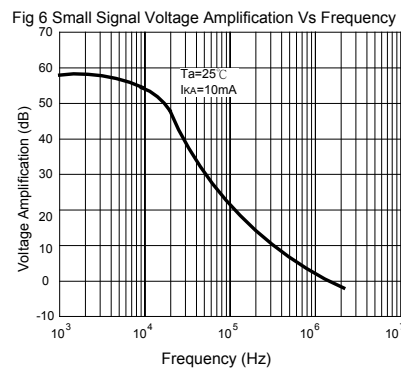
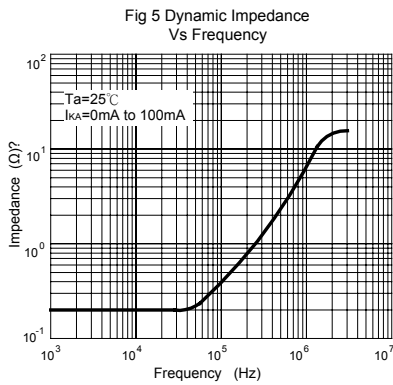
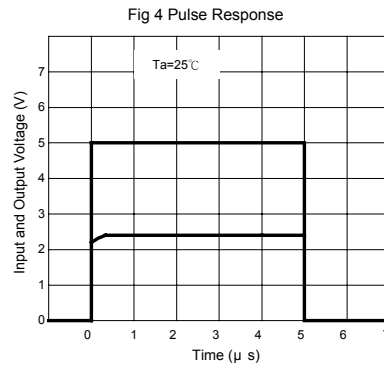
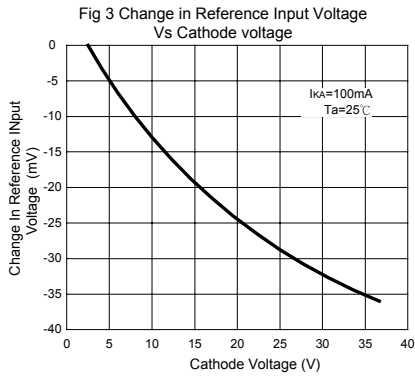
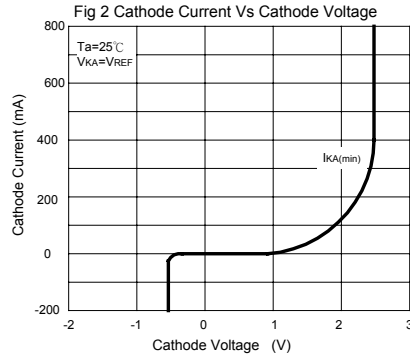
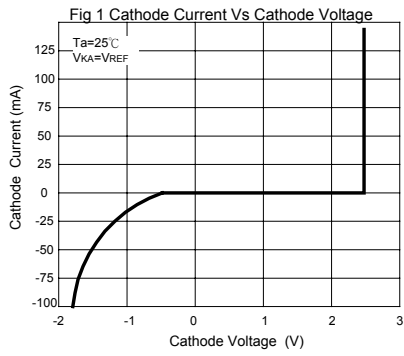

UTC TL431A LINEAR INTEGRATED CIRCUIT

TEST CIRCUIT

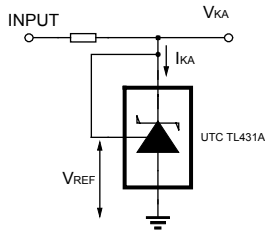

Fig 7 Test Circuit For $V_{KA}=V_{REF}$

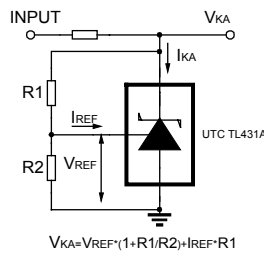

Fig 8 Test Circuit for $V_{KA} \geq V_{REF}$

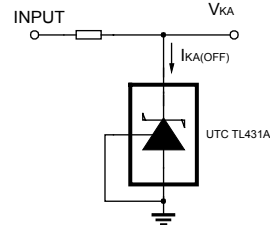

Fig 9 Test Circuit For $I_{KA(OFF)}$

APPLICATION CIRCUIT

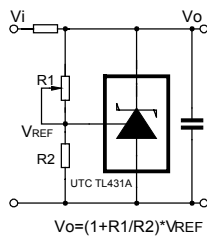

Fig 10 Shutdown Regulator

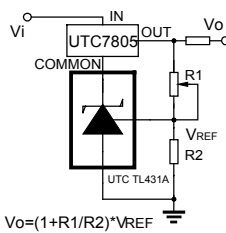

Fig 11 Output Control of a Three-Terminal Fixed Regulator

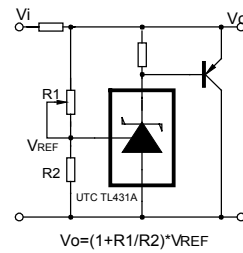

Fig 12 Higher-current Shunt Regulator

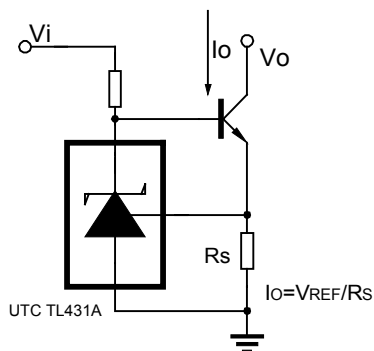

Fig 13 Constant-current Sink

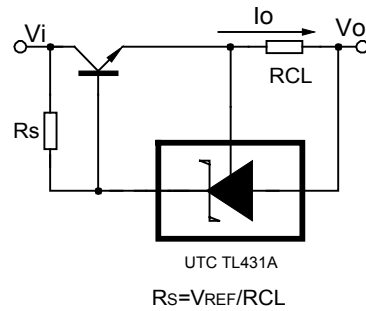

Fig 14 Current Limiting or Current Source

UTC TL431A LINEAR INTEGRATED CIRCUIT

UTC assumes no responsibility for equipment failures that result from using products at values that exceed, even momentarily, rated values (such as maximum ratings, operating condition ranges, or other parameters) listed in products specifications of any and all UTC products described or contained herein. UTC products are not designed for use in life support appliances, devices or systems where malfunction of these products can be reasonably expected to result in personal injury. Reproduction in whole or in part is prohibited without the prior written consent of the copyright owner. The information presented in this document does not form part of any quotation or contract, is believed to be accurate and reliable and may be changed without notice.