

Microwave Motion Sensor

KMY 10

Description

The KMY 10 is a microwave radar motion sensor based on the Doppler effect. It transmits a low energy microwave radiation at 9.35 GHz which is reflected by objects. If the object is moving relative to the sensor, a Doppler shift occurs. The shifted wave is mixed with the original wave, resulting in an output voltage.



Features

- High sensitivity
- Low power consumption
- High reliability
- Small size
- Light weight
- Low cost

Typ	Marking	Ordering Code	License No.
KMY 10	KMY 10 (or SMX-1 ¹⁾)	Q62702-R309	Germany: BZT B129549H Switzerland: BAKOM 92.1340.H.P Austria: GZ 104 091-ZB/96

1) Previous type designation SMX-1.

Pin Configuration

1	$-V_S$ (GND)
2	V_D (output voltage)
3	$+V_S$

Notes:

1. The adjustment screw located on the top face of the sensor housing is used to set the oscillator frequency. This adjustment is made and secured during production and to ensure the correct operation of the device it **must not be tampered** with!
2. Only the pads marked 1; 2; 3, are predetermined solder pads and only these pads should be used to connect the device. Soldering or otherwise interfering with any other parts of the AF-circuit board will immediately invalidate any warranty on the device!
3. The KMY 10 is classified as an Electrostatic Discharge Sensitive Device. Handling precautions for such devices must be adhered to!
4. **Regulations on the use of High frequency devices.**
The use of high frequency devices is regulated in most countries and certain frequencies can be subject to restrictions. The use of the KMY 10 should be clarified with the respective authorities in each country to ensure compliance with the prevalent legislation.

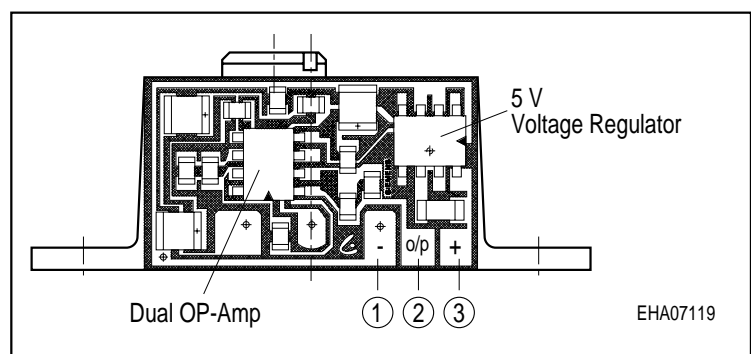

Maximum Ratings

Parameter	Symbol	Value	Unit
Supply voltage	V_{IN}	15	V
Output current	I_{OUT}	5	mA
Operating temperature range	T_A	- 20 ... + 60	°C
Storage temperature range	T_{stg}	- 50 ... + 125	°C

Electrical Characteristics

at $T_A = 25\text{ °C}$ and $V_{IN} = 12\text{ V}$, unless otherwise specified.

Parameter	Symbol	Limit Values			Unit
		min.	typ.	max.	
Supply voltage	V_{IN}	8	12	15	V
Operating current	I_{IN}	–	25	–	mA
Power at f_0	$EIRP_1$	–	0	+ 2	dBm
Frequency	f_0	9.33	9.35	9.37	GHz
Output voltage signal	$V_{out,0-peak}$	–	50 ¹⁾	–	mV
DC output voltage (offset)	V_0	–	2.5	–	V
Output noise voltage ²⁾	$V_{N,0-peak}$	–	10	20	mV
Frequency drift vs. temperature ³⁾	df_T	–	± 6	–	MHz
Frequency drift vs. operating voltage	df_V	–	± 0.1	–	MHz
Preamp voltage gain	G	–	920	–	
Preamp bandwidth	B	–	2 - 750	–	Hz
Time between power on until first detection	t_p		4		s

1) Person at 5 m distance

2) With no object detected

3) Defined over - 20 °C ... + 60 °C

LF-circuit Diagram

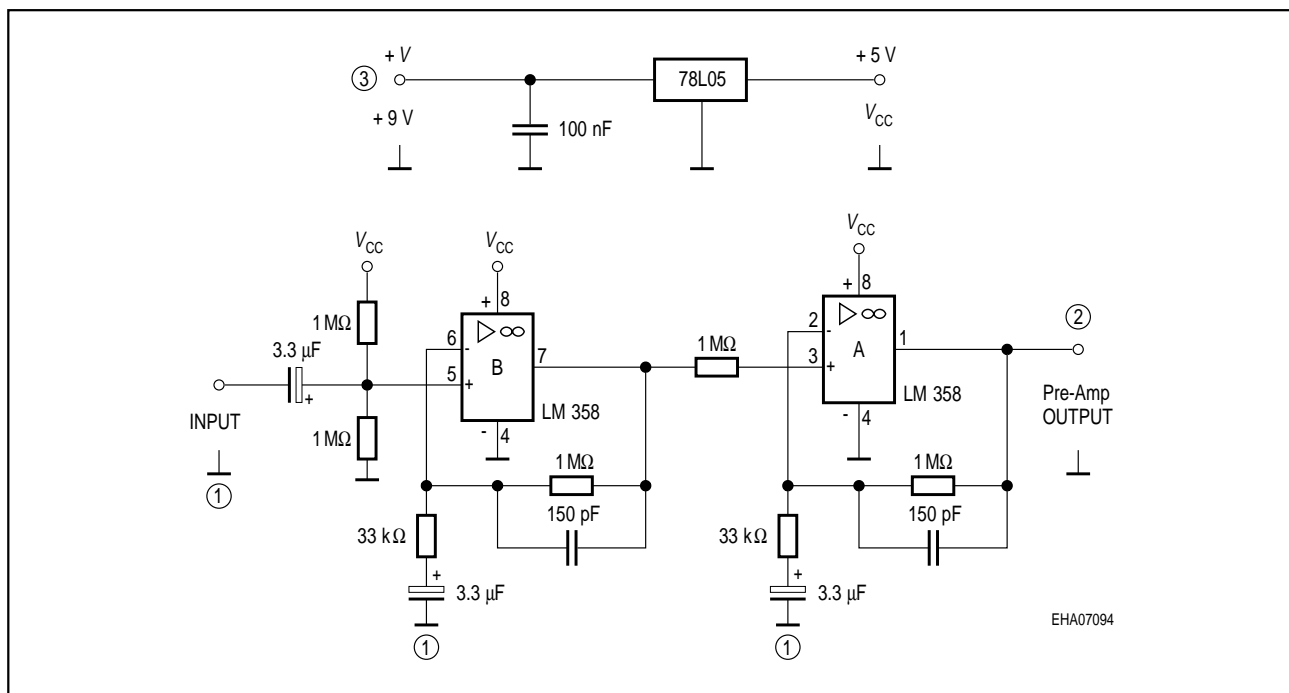

Application Example

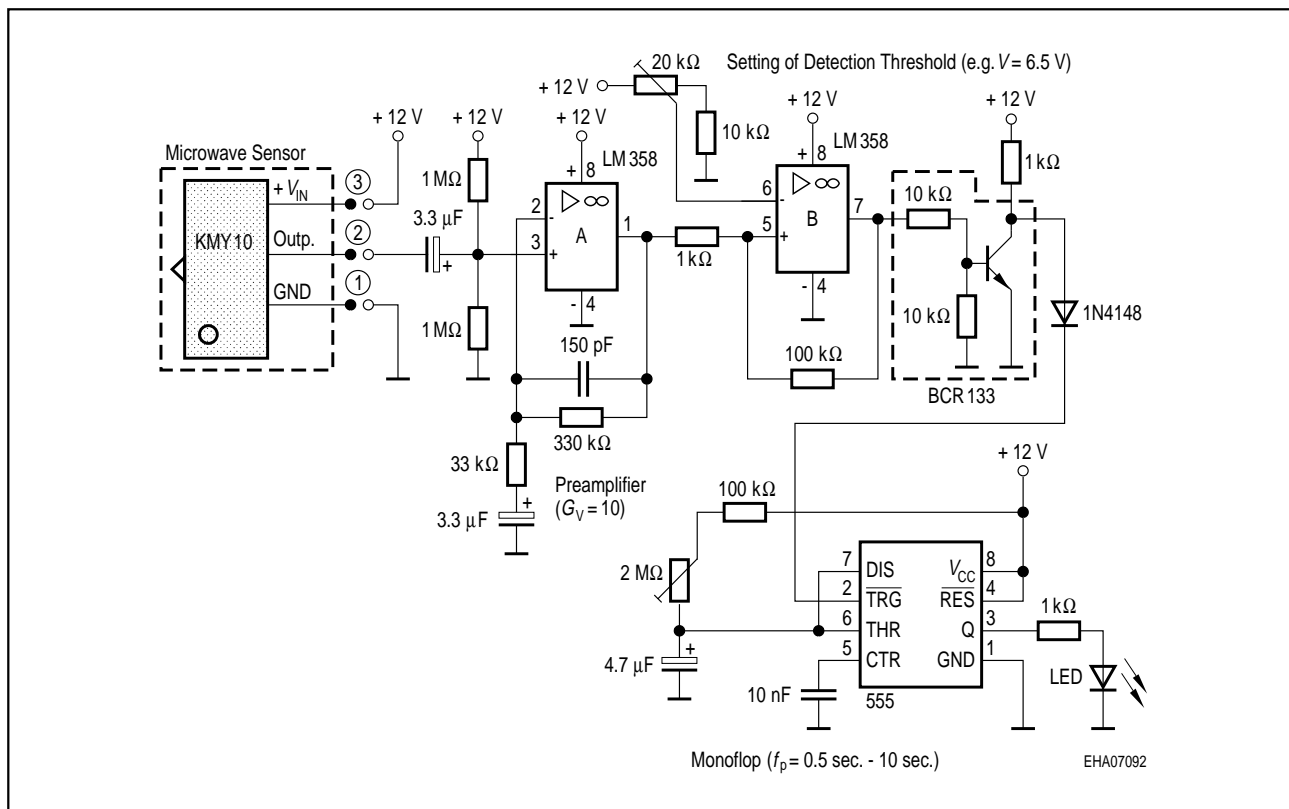

Note: The influence of fluorescent light interference (100 Hz carrier) has to be reduced by the installation of an additional 100 Hz notch filter.

Typical Radiation Pattern

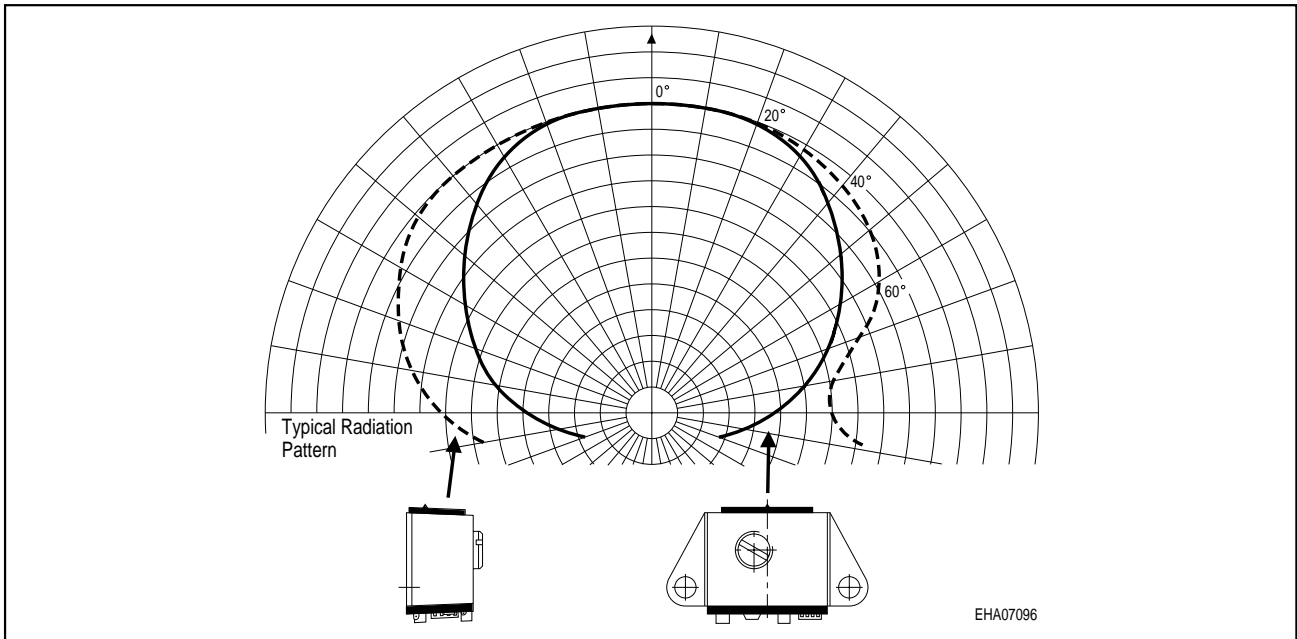

Package Outline

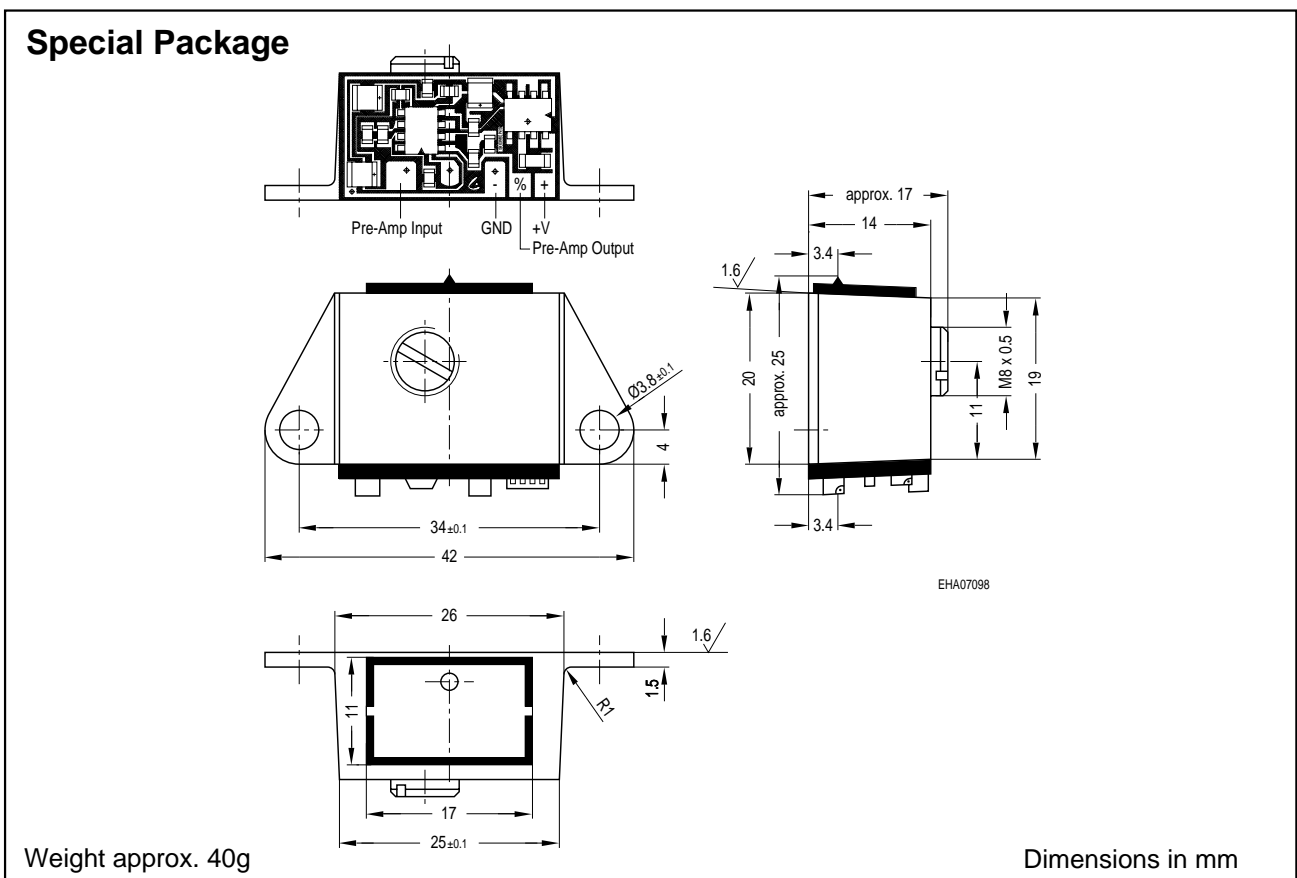

Exterior Packaging

I.e. tubes, trays, boxes are shown in our Data Book "Package Information".