

## Microwave Motion Sensor Preliminary Data

KMY 24

### Description

The KMY 24 is a microwave radar motion sensor based on the Doppler effect. It transmits a low energy microwave radiation at 2.45 GHz which is reflected by objects. If the object is moving relative to the sensor, a Doppler shift occurs. The shifted wave is mixed with the original wave in two mixers, resulting in two output voltage signals. The phase shift between these two signals is negative or positive depending on whether the target is approaching or receding from the detector.

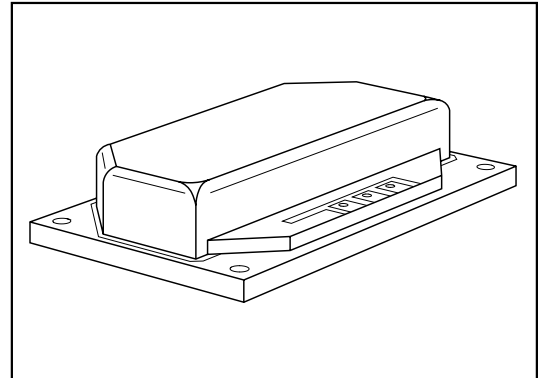

Engineering Sample

### Features

- High sensitivity
- Dual Mixers enabling direction detecting
- High reliability
- Low power consumption
- Low harmonic emission
- Small size
- Light weight
- Low cost

Typ	Marking	Ordering Code	Operating frequency	License No.
KMY 24	KMY 24	Q62702-R323	2.45 GHz	BZT G127520H

### Pin Configuration

1	$-V_S$ (GND)
2	$V_{D1}$ (output voltage D1)
3	$V_{D2}$ (output voltage D2)
4	$+V_S$

#### Notes:

1. Solder pads must not be perforated, as this will damage, and may destroy the multilayer PC Board.
2. **Regulations on the use of High frequency devices.**  
The use of high frequency devices is regulated in most countries and certain frequencies can be subject to restrictions. The use of the KMY 24 should be clarified with the respective authorities in each country to ensure compliance with the prevalent legislation.

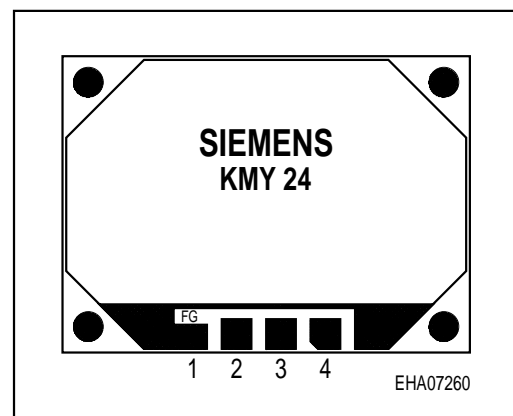

## Absolute Maximum Ratings

Parameter	Symbol	Limit Values	Unit
Operating temperature range	$T_{op}$	- 20 ... + 60	°C
Storage temperature range	$T_{stg}$	- 30 ... + 80	°C
Supply voltage	$V_S$	15.6	V

## Electrical Characteristics

at  $T_A = 25\text{ °C}$

Parameter	Symbol	Limit Values			Unit
		min.	typ.	max	
Supply voltage	$V_S$	10.8	12	15.6	V
Operating frequency	$f_o$	2.40	2.45	2.48	GHz
Operating current	$I_{op}$	-	23	-	mA
Detecting range <sup>1)</sup>	$r_{op}$	-	5 ... 8	-	m
Amplitude of signal 1	$V_{D1}$	-	<sup>1)</sup>	-	mV
Quotient of amplitude of 1 and 2	$V_{D1}/V_{D2}$	-	2	-	
Phase difference	$\phi_2 - \phi_1$	-	40 ... 120	-	Degrees
Equivalent isotropic radiated power at $f_o$	<i>EIRP</i>	-	8	-	dBm

1) The amplitude of the signal depends on the object size and its distance from the detector. Measurements taken with 5 cm high, cylindrical metallic objects, moving in circles at a distance of 1 m for example, give signal amplitudes of typically  $V_{D1} = 40\text{ mV}$ .

## Output Signal

The phase difference between  $V_{D2}$  and  $V_{D1}$  is positive, if the target is receding from the detector.

$$(\varphi_1 - \varphi_2) \geq 0$$

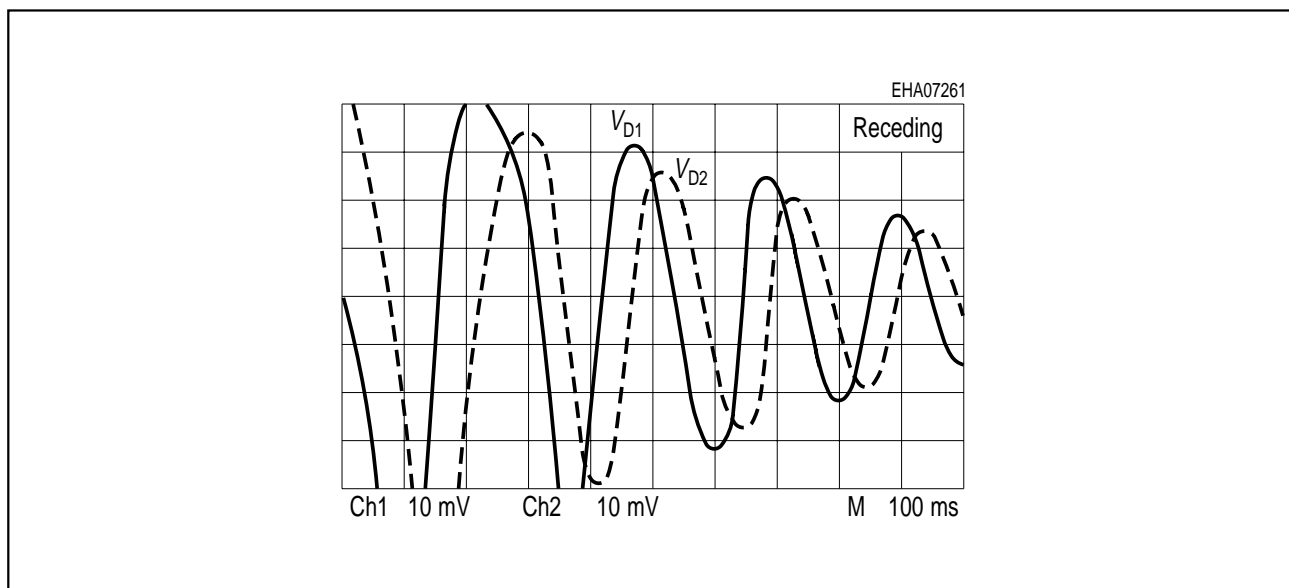

The phase difference between  $V_{D2}$  and  $V_{D1}$  is negative, if the target is approaching the detector.

$$(\varphi_1 - \varphi_2) \geq 0$$

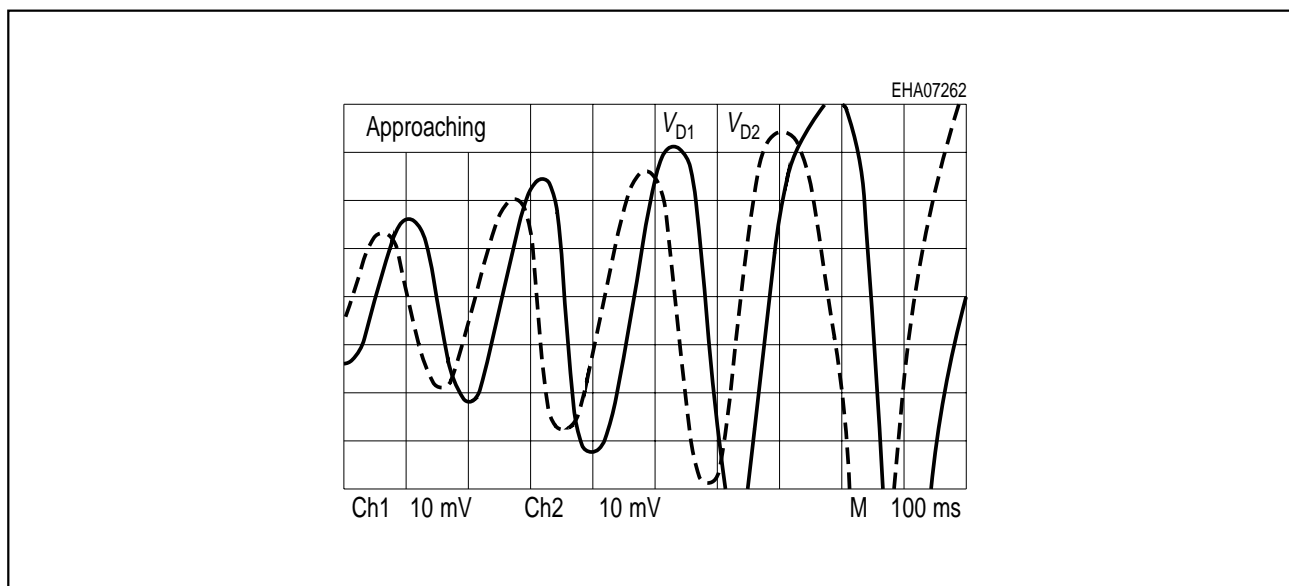

**Typical Radiation Pattern**

The diagram shows the typical radiation pattern in the x-z- and y-z-planes. The z-direction is perpendicular to the patch antenna, x shows the longer and y the shorter side of the rectangular antenna.

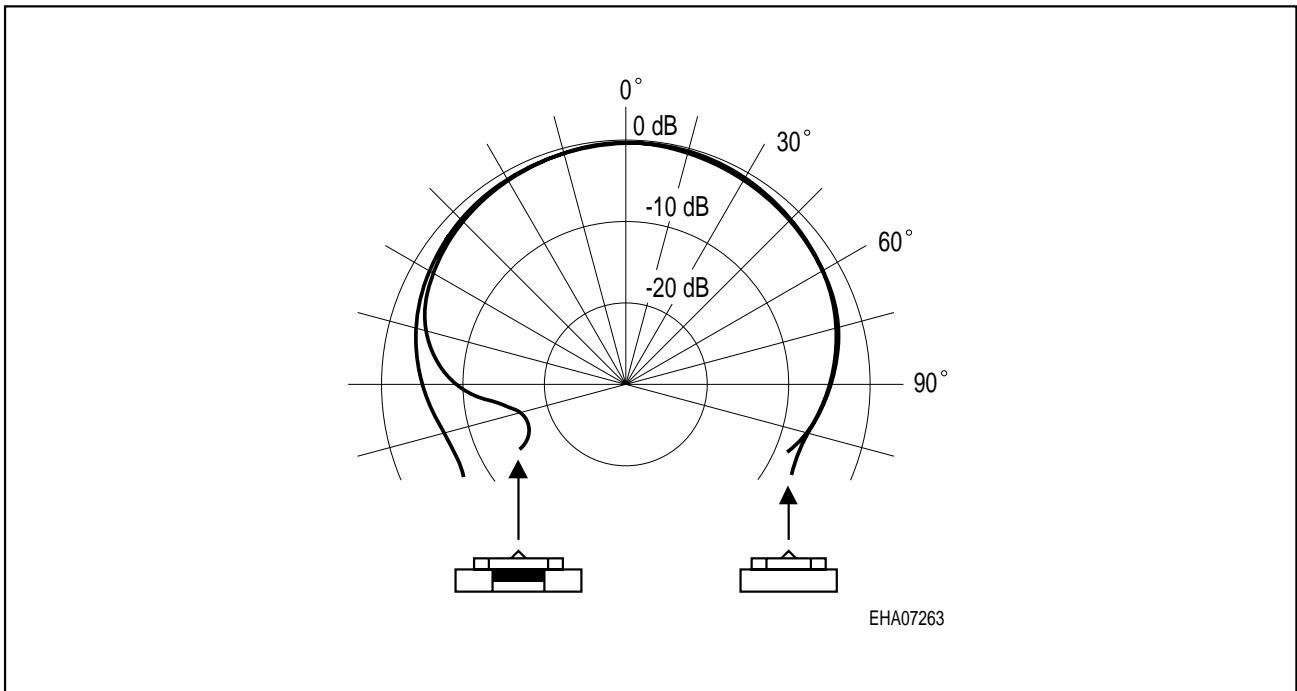

**Package Outline**

The outline of the package has, to date, not been determined.