

GENERAL DESCRIPTION

The JTDA50 is a common basis transistor providing 50 watts of pulsed RF output power across the 960-1215 MHz Band. This hermetically sealed transistor is specifically designed for JTIDS and other similar high power, long pulse width, high duty cycle applications. It utilizes gold metallization and emitter ballasting to provide ruggedness and high reliability along with internal matching for ease of design.

JTDA50
50 WATTS - 36 VOLTS
960-1215 MHz

ABSOLUTE MAXIMUM RATINGS

Maximum Power Dissipation @ 25°C Case Temperature	220 W
Maximum Voltage and Current	
BVces Collector to Emitter Voltage	55 V
BVebo Emitter to Base Voltage	3.5 V
Ic Collector Current	7.0 A
Maximum Temperatures	
Storage Temperature	-65 to +200 °C
Operating Junction Temperature	+200 °C

AVIONICS

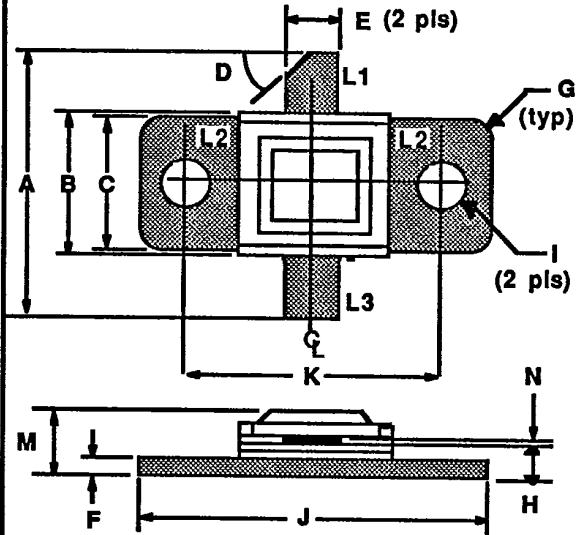

DIM	Millimeter	TOL	Inches	TOL
L1 : c				
L2 : b				
L3 : e				
A	20.32	.76	.800	.030
B	10.16	.13	.400	.005
C	9.78	.13	.385	.005
D	45°	5°	45°	5°
E	3.81	.13	.150	.005
F	1.52	.13	.060	.005
G	1.52 R	.13	.060 R	.005
H	3.05	.13	.120	.005
I	3.30 DIA	.13	.130 DIA	.005
J	22.86	.13	.900	.005
K	16.51	.13	.650	.005
M	5.46	REF	.215	REF
N	0.13	.02	.005	.001

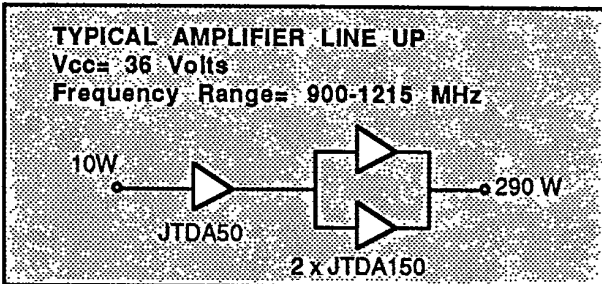

JTDA50-2

ELECTRICAL CHARACTERISTICS¹

SYMBOL	CHARACTERISTICS	TEST CONDITIONS	MIN.	TYP.	MAX.	UNITS
P_{out}^2	Power Output	f=960-1215 MHz Vcc= 25 mA	50			Watts
P_{in}^2	Power Input				10	Watts
P_g^2	Power Gain		7.0			dB
η_c	Collector Efficiency			40		%
VSWR ²	Load Mismatch Tolerance	f= 960 MHz			10:1	
BVebo	Breakdown Voltage (Emitter to Base)	Ic= 0A, Ie= 25mA	3.5			Volts
BVces	Breakdown Voltage (Collector to Emitter)	Vbe= 0A, Ic= 25mA	55			Volts
h_{FE}	DC-Current Gain	Ic= 750 mA, Vce= 5V	20		100	
θ_{jc}	Thermal Resistance				0.8	C/W

Note 1: Tc = +25°C unless otherwise specified

Note 2: Pulse Width = 10 µsec; Duty Cycle= 20%; Vcc= 36 Volts

SPECIFICATIONS MAY BE SUBJECT TO CHANGE WITHOUT NOTICE

95