

FIN1217 • FIN1218 • FIN1215 • FIN1216 LVDS 21-Bit Serializers/De-Serializers

General Description

The FIN1217 and FIN1215 transform 21-bit wide parallel LVTTTL (Low Voltage TTL) data into 3 serial LVDS (Low Voltage Differential Signaling) data streams. A phase-locked transmit clock is transmitted in parallel with the data stream over a separate LVDS link. Every cycle of transmit clock 21 bits of input LVTTTL data are sampled and transmitted.

The FIN1218 and FIN1216 receive and convert the 3 serial LVDS data streams back into 21 bits of LVTTTL data. Refer to Table 1 for a matrix summary of the Serializers and De-serializers available. For the FIN1217, at a transmit clock frequency of 85 MHz, 21 bits of LVTTTL data are transmitted at a rate of 595 Mbps per LVDS channel.

These chipsets are an ideal solution to solve EMI and cable size problems associated with wide and high-speed TTL interfaces.

Features

- Low power consumption
- 20 MHz to 85 MHz shift clock support
- 50% duty cycle on the clock output of receiver
- ±1V common-mode range around 1.2V
- Narrow bus reduces cable size and cost
- High throughput (up to 1.785 Gbps throughput)
- Up to 595 Mbps per channel
- Internal PLL with no external component
- Compatible with TIA/EIA-644 specification
- Devices are offered in 48-lead TSSOP packages

Ordering Code:

Order Number	Package Number	Package Description
FIN1215MTD	MTD48	48-Lead Thin Shrink Small Outline Package (TSSOP), JEDEC MO-153, 6.1mm Wide
FIN1215MTDX_NL (Note 1)	MTD48	Pb-Free 48-Lead Thin Shrink Small Outline Package (TSSOP), JEDEC MO-153, 6.1mm Wide
FIN1216MTD	MTD48	48-Lead Thin Shrink Small Outline Package (TSSOP), JEDEC MO-153, 6.1mm Wide
FIN1216MTDX_NL (Note 1)	MTD48	Pb-Free 48-Lead Thin Shrink Small Outline Package (TSSOP), JEDEC MO-153, 6.1mm Wide
FIN1217MTD	MTD48	48-Lead Thin Shrink Small Outline Package (TSSOP), JEDEC MO-153, 6.1mm Wide
FIN1218MTD	MTD48	48-Lead Thin Shrink Small Outline Package (TSSOP), JEDEC MO-153, 6.1mm Wide

Devices also available in Tape and Reel. Specify by appending suffix letter "X" to the ordering code.

Note 1: "_NL" indicates Pb-Free package (per JEDEC J-STD-020B). Device available in Tape and Reel only.

TABLE 1. Serializers/De-Serializers Chip Matrix

Part	CLK Frequency	LVTTTL IN	LVDS OUT	LVDS IN	LVTTTL OUT	Package
FIN1217	85	21	3			48 TSSOP
FIN1218	85			3	21	48 TSSOP
FIN1215	66	21	3			48 TSSOP
FIN1216	66			3	21	48 TSSOP

Block Diagrams

Transmitter Functional Diagram for FIN1217 and FIN1215

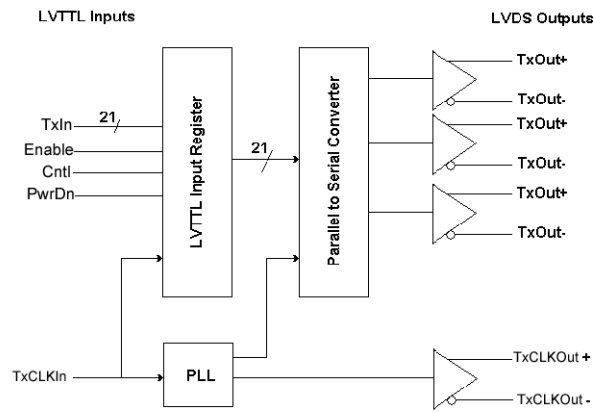

Receiver Functional Diagram for FIN1218 and FIN1216

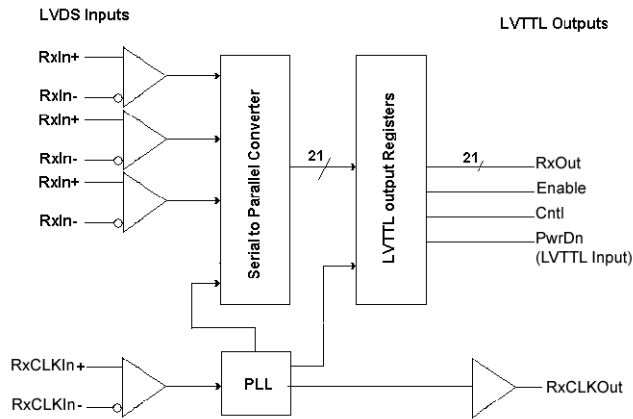

Transmitters

Pin Descriptions

Pin Names	I/O Type	Number of Pins	Description of Signals
TxIn	I	21	LVTTTL Level Inputs
TxCLKIn	I	1	LVTTTL Level Clock Input The rising edge is for data strobe.
TxOut+	O	3	Positive LVDS Differential Data Output
TxOut-	O	3	Negative LVDS Differential Data Output
TxCLKOut+	O	1	Positive LVDS Differential Clock Output
TxCLKOut-	O	1	Negative LVDS Differential Clock Output
PwrDn	I	1	LVTTTL Level Power-Down Input Assertion (LOW) puts the outputs in high-impedance state.
PLL V _{CC}	I	1	Power Supply Pin for PLL
PLL GND	I	2	Ground Pins for PLL
LVDS V _{CC}	I	1	Power Supply Pin for LVDS Outputs
LVDS GND	I	3	Ground Pins for LVDS Outputs
V _{CC}	I	4	Power Supply Pins for LVTTTL Inputs
GND	I	5	Ground pins for LVTTTL Inputs
NC			No Connect

Connection Diagram

FIN1217 and FIN1215 (21:3 Transmitter)
Pin Assignment for TSSOP

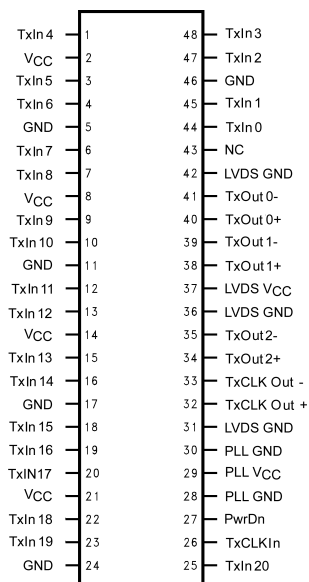

Receivers

Pin Descriptions

Pin Names	I/O Type	Number of Pins	Description of Signals
RxIn	I	3	Negative LVDS Differential Data Inputs
RxIn+	I	3	Positive LVDS Differential Data Inputs
RxCLKIn-	I	1	Negative LVDS Differential Clock Input
RxCLKIn+	I	1	Positive LVDS Differential Clock Input
RxOut	O	21	LVTTTL Level Data Outputs Goes HIGH for PwrDn LOW
RxCLKOut	O	1	LVTTTL Clock Output
PwrDn	I	1	LVTTTL Level Input Refer to Transmitter and Receiver Power-Up and Power-Down Operation Truth Table
PLL V _{CC}	I	1	Power Supply Pin for PLL
PLL GND	I	2	Ground Pins for PLL
LVDS V _{CC}	I	1	Power Supply Pin for LVDS Inputs
LVDS GND	I	3	Ground Pins for LVDS Inputs
V _{CC}	I	4	Power Supply for LVTTTL Outputs
GND	I	5	Ground Pins for LVTTTL Outputs
NC			No Connect

Connection Diagram

**FIN1218 and FIN1216 (3:21 Receiver)
Pin Assignment for TSSOP**

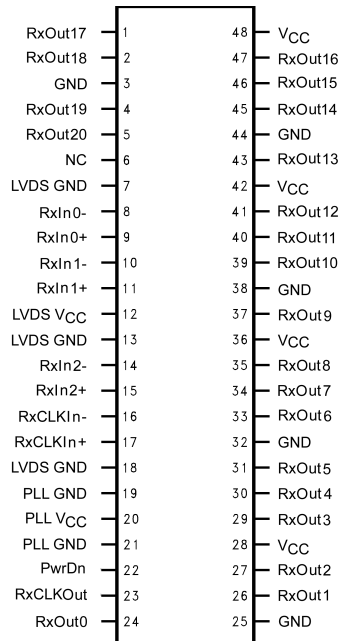

Truth Tables

Transmitter Truth Table

Inputs			Outputs	
TxIn	TxCLKIn	PwrDn (Note 2)	TxOut±	TxCLKOut±
Active	Active	H	L/H	L/H
Active	L/H/Z	H	L/H	X (Note 3)
F	Active	H	L	L/H
F	F	H	L	X (Note 3)
X	X	L	Z	Z

H = HIGH Logic Level
 L = LOW Logic Level
 X = Don't Care
 Z = High Impedance
 F = Floating

Note 2: The outputs of the transmitter or receiver will remain in a High Impedance state until V_{CC} reaches 2V.

Note 3: TxCLKOut± will settle at a free running frequency when the part is powered up, PwrDn is HIGH and the TxCLKIn is a steady logic level (L/H/Z).

Receiver Truth Table

Inputs			Outputs	
RxIn±	RxCLKIn±	PwrDn (Note 4)	RxOut	RxCLKOut
Active	Active	H	L/H	L/H
Active	F (Note 5)	H	P	H
F (Note 5)	Active	H	H	L/H
F (Note 5)	F (Note 5)	H	P (Note 6)	H
X	X	L	L	H

H = HIGH Logic Level
 L = LOW Logic Level
 P = Last Valid State
 X = Don't Care
 Z = High Impedance
 F = Failsafe Condition

Note 4: The outputs of the transmitter or receiver will remain in a High Impedance state until V_{CC} reaches 2V.

Note 5: Failsafe condition is defined as the input being terminated and un-driven (Z) or shorted or open.

Note 6: If RxCLKIn± is removed prior to the RxIn± data being removed, RxOut will be the last valid state. If RxIn± data is removed prior to RxCLKIn± being removed, RxOut will be HIGH.

Absolute Maximum Ratings (Note 7)

Power Supply Voltage (V_{CC})	-0.3V to +4.6V
TTL/CMOS Input/Output Voltage	-0.5V to +4.6V
LVDS Input/Output Voltage	-0.3V to +4.6V
LVDS Output Short Circuit Current (I_{OSD})	Continuous
Storage Temperature Range (T_{STG})	-65°C to +150°C
Maximum Junction Temperature (T_J)	150°C
Lead Temperature (T_L) (Soldering, 4 seconds)	260°C
ESD Rating (HBM, 1.5 k Ω , 100 pF)	
LVDS I/O to GND	>10.0 kV
All Pins (FIN1215, FIN1217 only)	>6.5 kV
ESD Rating (MM, 0 Ω , 200 pF) (FIN1215, FIN1217 only)	>400V

Recommended Operating Conditions

Supply Voltage (V_{CC})	3.0V to 3.6V
Operating Temperature (T_A)(Note 7)	-40°C to +85°C
Maximum Supply Noise Voltage (V_{CCNPP})	100 mV _{P-P} (Note 8)

Note 7: Absolute maximum ratings are DC values beyond which the device may be damaged or have its useful life impaired. The datasheet specifications should be met, without exception, to ensure that the system design is reliable over its power supply, temperature, and output/input loading variables. Fairchild does not recommend operation outside datasheet specifications.

Note 8: 100mV V_{CC} noise should be tested for frequency at least up to 2 MHz. All the specification below should be met under such a noise.

Transmitter DC Electrical Characteristics

Over supply voltage and operating temperature ranges, unless otherwise specified. (Note 9)

Symbol	Parameter	Test Conditions	Min	Typ	Max	Units
Transmitter LVTTTL Input Characteristics						
V_{IH}	Input High Voltage		2.0		V_{CC}	V
V_{IL}	Input Low Voltage		GND		0.8	V
V_{IK}	Input Clamp Voltage	$I_{IK} = -18$ mA		-0.79	-1.5	V
I_{IN}	Input Current	$V_{IN} = 0.4V$ to 4.6V		1.8	10.0	μ A
		$V_{IN} = GND$	-10.0	0		
Transmitter LVDS Output Characteristics (Note 10)						
V_{OD}	Output Differential Voltage		250		450	mV
ΔV_{OD}	V_{OD} Magnitude Change from Differential LOW-to-HIGH	$R_L = 100 \Omega$, See Figure 1			35.0	mV
V_{OS}	Offset Voltage		1.125	1.25	1.375	V
ΔV_{OS}	Offset Magnitude Change from Differential LOW-to-HIGH					mV
I_{OS}	Short Circuit Output Current	$V_{OUT} = 0V$		-3.5	-5.0	mA
I_{OZ}	Disabled Output Leakage Current	$DO = 0V$ to 4.6V, $\overline{PwrDn} = 0V$		± 1.0	± 10.0	μ A
Transmitter Supply Current						
I_{CCWT}	21:3 Transmitter Power Supply Current for Worst Case Pattern (With Load) (Note 11), (Note 12) (85.0 MHz Specification for FIN1217 only)	$R_L = 100 \Omega$, See Figure 3	33.0 MHz	28.0	46.2	mA
			40.0 MHz	29.0	51.7	
			65.0 MHz	34.0	57.2	
			85.0 MHz	39.0	62.7	
I_{CCPDT}	Powered Down Supply Current	$\overline{PwrDn} = 0.8V$		10.0	55.0	μ A

Note 9: All Typical values are at $T_A = 25^\circ\text{C}$ and with $V_{CC} = 3.3V$.

Note 10: Positive current values refer to the current flowing into device and negative values means current flowing out of pins. Voltage are referenced to ground unless otherwise specified (except ΔV_{OD} and V_{OD}).

Note 11: The power supply current for both transmitter and receiver can be different with the number of active I/O channels.

Note 12: The 16-grayscale test pattern tests device power consumption for a "typical" LCD display pattern. The test pattern approximates signal switching needed to produce groups of 16 vertical strips across the display.

Transmitter AC Electrical Characteristics

Over supply voltage and operating temperature ranges, unless otherwise specified.

Symbol	Parameter	Test Conditions	Min	Typ	Max	Units
t _{TCP}	Transmit Clock Period		11.76	T	50.0	ns
t _{TCH}	Transmit Clock (TxCLKIn) HIGH Time	See Figure 6	0.35	0.5	0.65	T
t _{TCL}	Transmit Clock Low Time		0.35	0.5	0.65	T
t _{CLKT}	TxCLKIn Transition Time (Rising and Falling)	(10% to 90%) See Figure 7	1.0		6.0	ns
t _{JIT}	TxCLKIn Cycle-to-Cycle Jitter				3.0	ns
t _{XIT}	TxIn Transition Time		1.5		6.0	ns
LVDS Transmitter Timing Characteristics						
t _{TLH}	Differential Output Rise Time (20% to 80%)	See Figure 4		0.75	1.5	ns
t _{THL}	Differential Output Fall Time (80% to 20%)			0.75	1.5	ns
t _{STC}	TxIn Setup to TxCLNIn	See Figure 6	2.5			ns
t _{HTC}	TxIn Holds to TCLKIn	(f = 85 MHz) (FIN1217 only)	0			ns
t _{PPD}	Transmitter Power-Down Delay	See Figure 13, (Note 13)			100	ns
t _{TCCD}	Transmitter Clock Input to Clock Output Delay	See Figure 9			5.5	ns
	Transmitter Clock Input to Clock Output Delay	(T _A = 25°C and with V _{CC} = 3.3V)	2.8		6.8	
Transmitter Output Data Jitter (f = 40 MHz) (Note 14)						
t _{TPPB0}	Transmitter Output Pulse Position of Bit 0	See Figure 16 $a = \frac{1}{f \times 7}$	-0.25	0	0.25	ns
t _{TPPB1}	Transmitter Output Pulse Position of Bit 1		a-0.25	a	a+0.25	ns
t _{TPPB2}	Transmitter Output Pulse Position of Bit 2		2a-0.25	2a	2a+0.25	ns
t _{TPPB3}	Transmitter Output Pulse Position of Bit 3		3a-0.25	3a	3a+0.25	ns
t _{TPPB4}	Transmitter Output Pulse Position of Bit 4		4a-0.25	4a	4a+0.25	ns
t _{TPPB5}	Transmitter Output Pulse Position of Bit 5		5a-0.25	5a	5a+0.25	ns
t _{TPPB6}	Transmitter Output Pulse Position of Bit 6		6a-0.25	6a	6a+0.25	ns
Transmitter Output Data Jitter (f = 65 MHz) (Note 14)						
t _{TPPB0}	Transmitter Output Pulse Position of Bit 0	See Figure 16 $a = \frac{1}{f \times 7}$	-0.2	0	0.2	ns
t _{TPPB1}	Transmitter Output Pulse Position of Bit 1		a-0.2	a	a+0.2	ns
t _{TPPB2}	Transmitter Output Pulse Position of Bit 2		2a-0.2	2a	2a+0.2	ns
t _{TPPB3}	Transmitter Output Pulse Position of Bit 3		3a-0.2	3a	3a+0.2	ns
t _{TPPB4}	Transmitter Output Pulse Position of Bit 4		4a-0.2	4a	4a+0.2	ns
t _{TPPB5}	Transmitter Output Pulse Position of Bit 5		5a-0.2	5a	5a+0.2	ns
t _{TPPB6}	Transmitter Output Pulse Position of Bit 6		6a-0.2	6a	6a+0.2	ns
Transmitter Output Data Jitter (f = 85 MHz) (FIN1217 only) (Note 14)						
t _{TPPB0}	Transmitter Output Pulse Position of Bit 0	See Figure 16 $a = \frac{1}{f \times 7}$	-0.2	0	0.2	ns
t _{TPPB1}	Transmitter Output Pulse Position of Bit 1		a-0.2	a	a+0.2	ns
t _{TPPB2}	Transmitter Output Pulse Position of Bit 2		2a-0.2	2a	2a+0.2	ns
t _{TPPB3}	Transmitter Output Pulse Position of Bit 3		3a-0.2	3a	3a+0.2	ns
t _{TPPB4}	Transmitter Output Pulse Position of Bit 4		4a-0.2	4a	4a+0.2	ns
t _{TPPB5}	Transmitter Output Pulse Position of Bit 5		5a-0.2	5a	5a+0.2	ns
t _{TPPB6}	Transmitter Output Pulse Position of Bit 6		6a-0.2	6a	6a+0.2	ns
t _{JCC}	FIN1217 Transmitter Clock Out Jitter (Cycle-to-Cycle) See Figure 19	f = 40 MHz		350	370	ps
		f = 65 MHz		210	230	
		f = 85 MHz (FIN1217 only)		110	150	
t _{TPLLS}	Transmitter Phase Lock Loop Set Time (Note 15)	See Figure 11, (Note 14)			10.0	ms

Note 13: Outputs of all transmitters stay in 3-STATE until power reaches 2V. Both clock and data output begins to toggle 10ms after V_{CC} reaches 3V and Power-Down pin is above 1.5V.

Note 14: This output data pulse position works for both transmitter with 21 TTL inputs except the LVDS output bit mapping difference (see Figure 15). Figure 16 shows the skew between the first data bit and clock output. Also 2-bit cycle delay is guaranteed when the MSB is output from transmitter.

Note 15: This jitter specification is based on the assumption that PLL has a ref clock with cycle-to-cycle input jitter less than 2ns.

Receiver DC Electrical Characteristics

Over supply voltage and operating temperature ranges, unless otherwise specified. (Note 16)

Symbol	Parameter	Test Conditions	Min	Typ	Max	Units	
LVTTTL/CMOS DC Characteristics							
V _{IH}	Input High Voltage		2.0		V _{CC}	V	
V _{IL}	Input Low Voltage		GND		0.8	V	
V _{OH}	Output High Voltage	I _{OH} = -0.4 mA	2.7	3.3		V	
V _{OL}	Output Low Voltage	I _{OL} = 2 mA			0.3	V	
V _{IK}	Input Clamp Voltage	I _{IK} = -18 mA			-1.5	V	
I _{IN}	Input Current	V _{IN} = 0V to 4.6V	-10.0		10.0	μA	
I _{OFF}	Input/Output Power Off Leakage Current	V _{CC} = 0V, All LVTTTL Inputs/Outputs 0V to 4.6V			±10.0	μA	
I _{OS}	Output Short Circuit Current	V _{OUT} = 0V		-60.0	-120	mA	
Receiver LVDS Input Characteristics							
V _{TH}	Differential Input Threshold HIGH	Figure 2, Table 2			100	mV	
V _{TL}	Differential Input Threshold LOW	Figure 2, Table 2	-100			mV	
V _{ICM}	Input Common Mode Range	Figure 2, Table 2	0.05		2.35	V	
I _{IN}	Input Current	V _{IN} = 2.4V, V _{CC} = 3.6V or 0V			±10.0	μA	
		V _{IN} = 0V, V _{CC} = 3.6V or 0V			±10.0	μA	
Receiver Supply Current							
I _{CCWR}	3:21 Receiver Power Supply Current for Worst Case Pattern (With Load) (Note 17) (85.0 MHz Specification for FIN1218 only)	C _L = 8 pF, See Figure 3	33.0 MHz			66.0	mA
			40.0 MHz		56.0	74.0	
			65.0 MHz		75.0	102	
			85.0 MHz		92.0	125	
I _{CCPDR}	Powered Down Supply Current	PwrDn = 0.8V (RxOut stays LOW)		NA	400	μA	
<p>Note 16: All Typical Values are at T_A = 25°C and with V_{CC} = 3.3V. Positive current values refer to the current flowing into device and negative values means current flowing out of pins. Voltage are referenced to ground unless otherwise specified (except ΔV_{OD} and V_{OD}).</p> <p>Note 17: The power supply current for the receiver can be different with the number of active I/O channels.</p>							

Receiver AC Electrical Characteristics						
Over supply voltage and operating temperatures, unless otherwise specified						
Symbol	Parameter	Test Conditions	Min	Typ	Max	Units
t _{RCOL}	RxCLKOut LOW Time	See Figure 8 (Rising Edge Strobe)	10.0	11.0		ns
t _{RCOH}	RxCLKOut HIGH Time		10.0	12.2		ns
t _{RSRC}	RxOut Valid Prior to RxCLKOut		6.5	11.6		ns
t _{RHRC}	RxOut Valid After RxCLKOut	(f = 40 MHz)	6.0	11.6		ns
t _{RCOP}	Receiver Clock Output (RxCLKOut) Period		15.0	T	50.0	ns
t _{RCOL}	RxCLKOut LOW Time	See Figure 8 (Rising Edge Strobe)	5.0	7.8	9.0	ns
t _{RCOH}	RxCLKOut HIGH Time		5.0	7.3	9.0	ns
t _{RSRC}	RxOut Valid Prior to RxCLKOut		(f = 65 MHz)	4.5	7.7	
t _{RHRC}	RxOut Valid After RxCLKOut		4.0	8.4		ns
t _{RCOP}	Receiver Clock Output (RxCLKOut) Period		11.76	T	50.0	ns
t _{RCOL}	RxCLKOut LOW Time	See Figure 8 (Rising Edge Strobe)	4.0	6.3	6.0	ns
t _{RCOH}	RxCLKOut HIGH Time		4.5	5.4	6.5	ns
t _{RSRC}	RxOut Valid Prior to RxCLKOut		(f = 85 MHz) (FIN1218 only)	3.5	6.3	
t _{RHRC}	RxOut Valid After RxCLKOut		3.5	6.5		ns
t _{ROLH}	Output Rise Time (20% to 80%)	C _L = 8 pF		2.2	5.0	ns
t _{ROHL}	Output Fall Time (80% to 20%)	See Figure 5		2.1	5.0	ns
t _{RCCD}	Receiver Clock Input to Clock Output Delay	See Figure 10 (Note 19) T _A = 25°C and V _{CC} = 3.3V	3.5	6.9	7.5	ns
t _{RPDD}	Receiver Power-Down Delay	See Figure 14			1.0	μs
t _{RSPB0}	Receiver Input Strobe Position of Bit 0	See Figure 17 (f = 40 MHz)	1.0		2.15	ns
t _{RSPB1}	Receiver Input Strobe Position of Bit 1		4.5		5.8	ns
t _{RSPB2}	Receiver Input Strobe Position of Bit 2		8.1		9.15	ns
t _{RSPB3}	Receiver Input Strobe Position of Bit 3		11.6		12.6	ns
t _{RSPB4}	Receiver Input Strobe Position of Bit 4		15.1		16.3	ns
t _{RSPB5}	Receiver Input Strobe Position of Bit 5		18.8		19.9	ns
t _{RSPB6}	Receiver Input Strobe Position of Bit 6		22.5		23.6	ns
t _{RSPB0}	Receiver Input Strobe Position of Bit 0	See Figure 17 (f = 65 MHz)	0.7		1.4	ns
t _{RSPB1}	Receiver Input Strobe Position of Bit 1		2.9		3.6	ns
t _{RSPB2}	Receiver Input Strobe Position of Bit 2		5.1		5.8	ns
t _{RSPB3}	Receiver Input Strobe Position of Bit 3		7.3		8.0	ns
t _{RSPB4}	Receiver Input Strobe Position of Bit 4		9.5		10.2	ns
t _{RSPB5}	Receiver Input Strobe Position of Bit 5		11.7		12.4	ns
t _{RSPB6}	Receiver Input Strobe Position of Bit 6		13.9		14.6	ns
t _{RSPB0}	Receiver Input Strobe Position of Bit 0	See Figure 17 (f = 85 MHz) (FIN1218 only)	0.49		1.19	ns
t _{RSPB1}	Receiver Input Strobe Position of Bit 1		2.17		2.87	ns
t _{RSPB2}	Receiver Input Strobe Position of Bit 2		3.85		4.55	ns
t _{RSPB3}	Receiver Input Strobe Position of Bit 3		5.53		6.23	ns
t _{RSPB4}	Receiver Input Strobe Position of Bit 4		7.21		7.91	ns
t _{RSPB5}	Receiver Input Strobe Position of Bit 5		8.89		9.59	ns
t _{RSPB6}	Receiver Input Strobe Position of Bit 6		10.57		11.27	ns
t _{RSKM}	RxIn Skew Margin (Note 18)	f = 40 MHz; See Figure 18	490			ps
		f = 65 MHz; See Figure 18	400			
		f = 85 MHz (FIN1218 only); See Figure 18	252			
t _{RPLLS}	Receiver Phase Lock Loop Set Time	See Figure 12			10.0	ms

Note 18: Receiver skew margin is defined as the valid sampling window after considering potential setup/hold time and minimum/maximum bit position.

Note 19: Total channel latency from serializer to deserializer is (T + t_{RCCD}) + (2T + t_{RCCD}). There is the clock period.

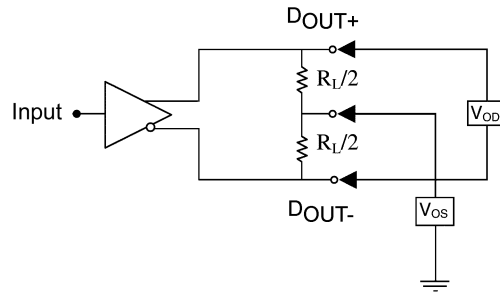
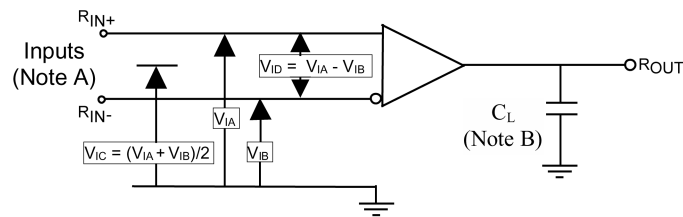

FIGURE 1. Differential LVDS Output DC Test Circuit



Note A: For all input pulses, t_R or $t_F <= 1$ ns.

Note B: C_L includes all probe and jig capacitance.

FIGURE 2. Differential Receiver Voltage Definitions and Propagation Delay and Transition Time Test Circuit

TABLE 2. Receiver Minimum and Maximum Input Threshold Test Voltages

Applied Voltages (V)		Resulting Differential Input Voltage (mV)	Resulting Common Mode Input Voltage (V)
V_{IA}	V_{IB}	V_{ID}	V_{IC}
1.25	1.15	100	1.2
1.15	1.25	-100	1.2
2.4	2.3	100	2.35
2.3	2.4	-100	2.35
0.1	0	100	0.05
0	0.1	-100	0.05
1.5	0.9	600	1.2
0.9	1.5	-600	1.2
2.4	1.8	600	2.1
1.8	2.4	-600	2.1
0.6	0	600	0.3
0	0.6	-600	0.3

AC Loading and Waveforms

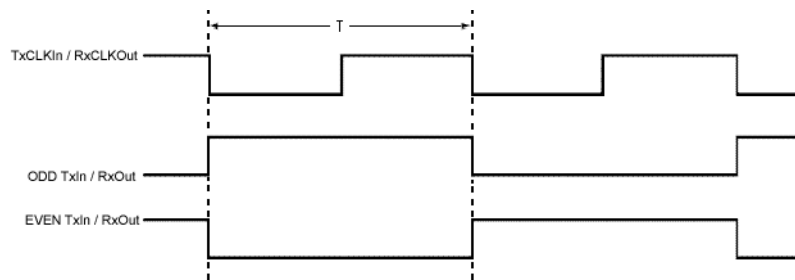

Note: The worst case test pattern produces a maximum toggling of digital circuits, LVDS I/O and LVTTTL/CMOS I/O. Depending on the valid strobe edge of transmitter, the TxCLKIn can be either rising or falling edge data strobe.

FIGURE 3. "Worst Case" Test Pattern

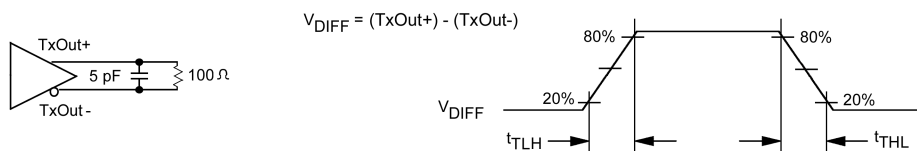

FIGURE 4. Transmitter LVDS Output Load and Transition Times



FIGURE 5. Receiver LVTTTL/CMOS Output Load and Transition Times

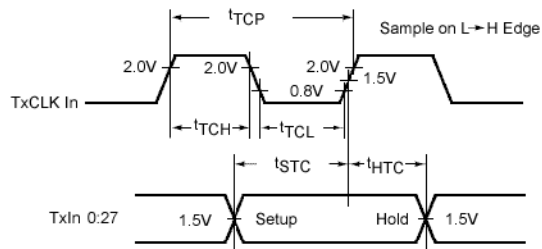

FIGURE 6. Transmitter Setup/Hold and HIGH/LOW Times (Rising Edge Strobe)

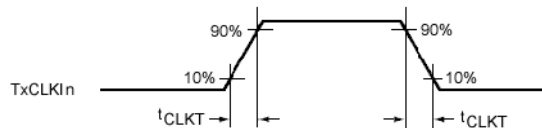

FIGURE 7. Transmitter Input Clock Transition Time

AC Loading and Waveforms (Continued)

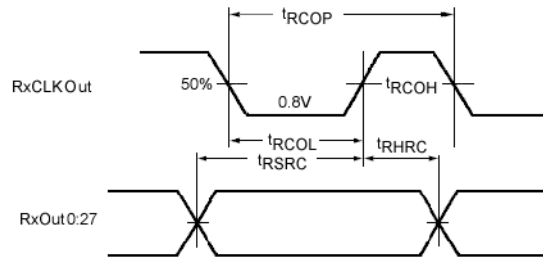

FIGURE 8. Receiver Setup/Hold and HIGH/LOW Times

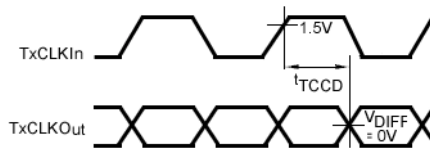

FIGURE 9. Transmitter Clock In to Clock Out Delay (Rising Edge Strobe)

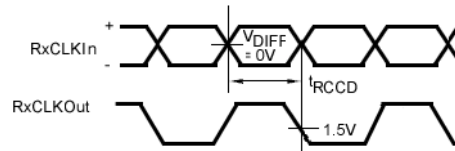

FIGURE 10. Receiver Clock In to Clock Out Delay (Falling Edge Strobe)

AC Loading and Waveforms (Continued)

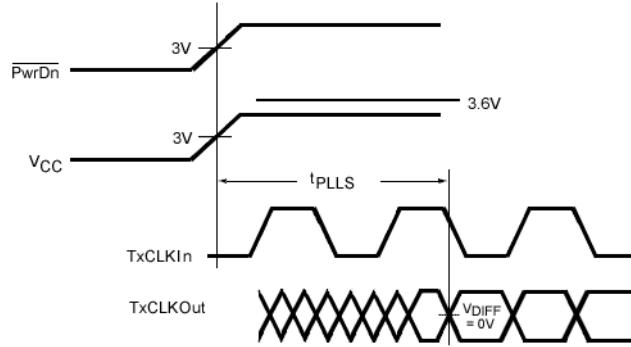

FIGURE 11. Transmitter Phase Lock Loop Set Time

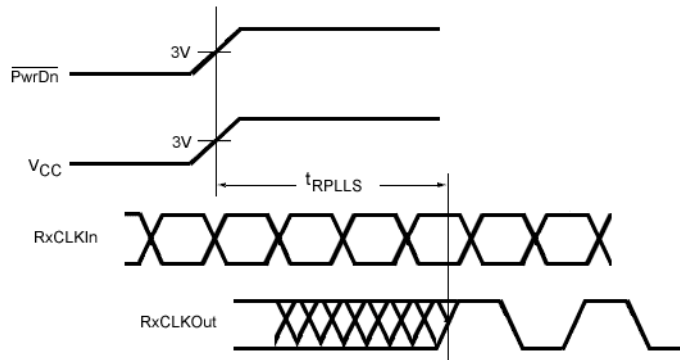

FIGURE 12. Receiver Phase Lock Loop Set Time

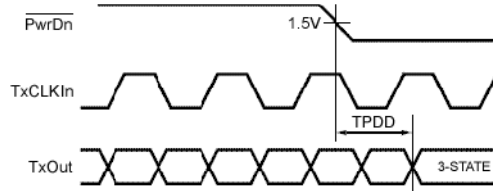

FIGURE 13. Transmitter Power-Down Delay

FIN1217 • FIN1218 • FIN1215 • FIN1216

AC Loading and Waveforms (Continued)

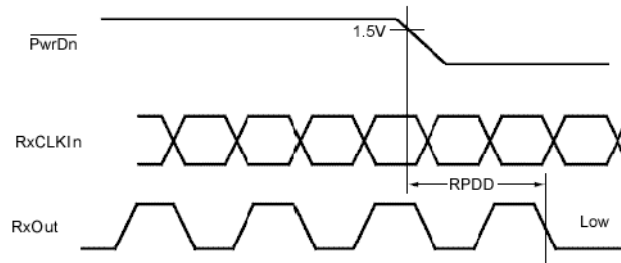
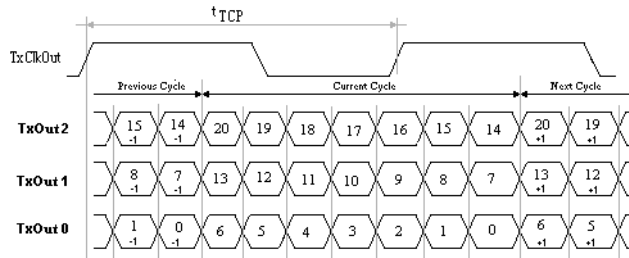

FIGURE 14. Receiver Power-Down Delay



Note: This output data pulse position works for both transmitter with 21 TTL inputs except the LVDS output bit mapping difference. All the information in this diagram tells that the skew between the first data bit and clock output. Also 2-bit cycle delay is guaranteed when the MSB is output from transmitter.

FIGURE 15. 21 Parallel LVTTL Inputs Mapped to 3 Serial LVDS Outputs

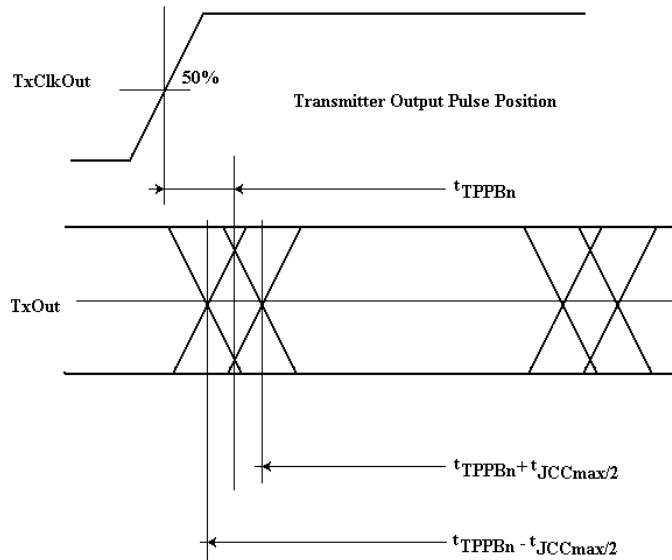

FIGURE 16. Transmitter Output Pulse Bit Position

AC Loading and Waveforms (Continued)

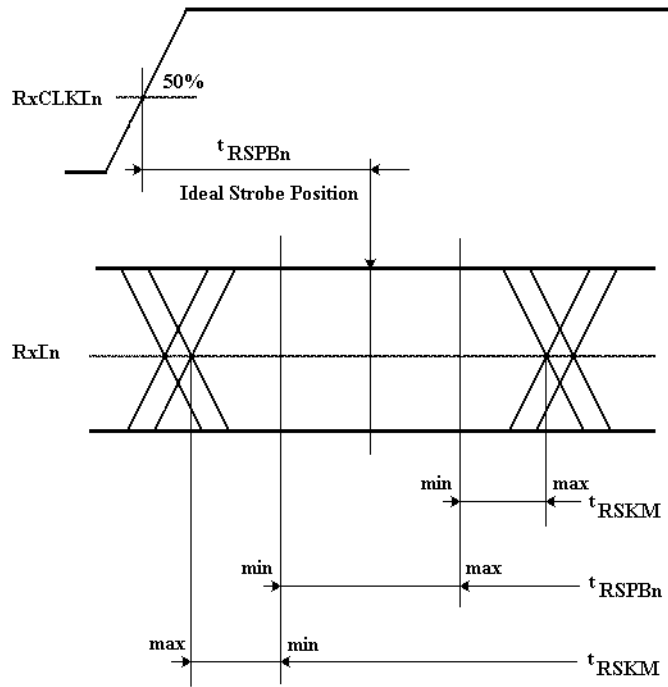
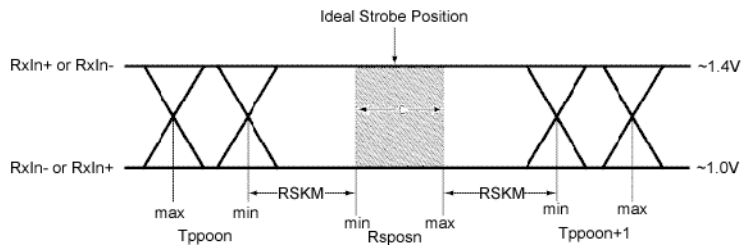

FIGURE 17. Receiver Input Strobe Bit Position



Note: t_{RSKM} is the budget for the cable skew and source clock skew plus ISI (Inter-Symbol Interference).

Note: The minimum and maximum pulse position values are based on the bit position of each of the 7 bits within the LVDS data stream across PVT (Process, Voltage Supply, and Temperature).

FIGURE 18. Receiver LVDS Input Skew Margin

AC Loading and Waveforms (Continued)

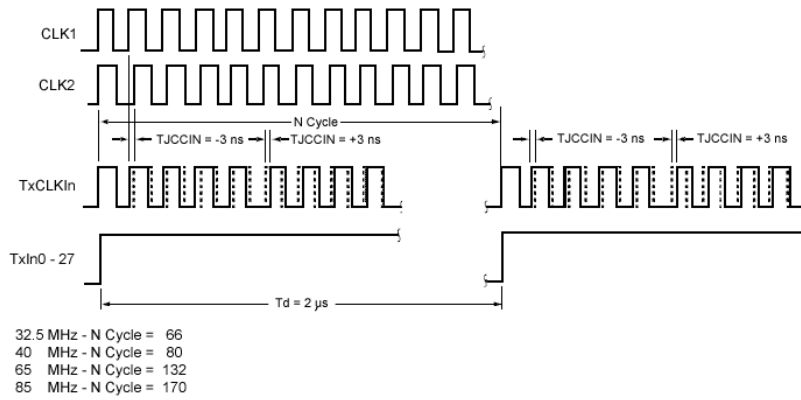

Note: This jitter pattern is used to test the jitter response (Clock Out) of the device over the power supply range with worst jitter $\pm 3\text{ns}$ (cycle-to-cycle) clock input. The specific test methodology is as follows:

- Switching input data TxIn0 to TxIn20 at 0.5 MHz, and the input clock is shifted to left -3ns and to the right $+3\text{ns}$ when data is HIGH (by switching between CLK1 and CLK2 in Figure 11)
- The $\pm 3\text{ns}$ cycle-to-cycle input jitter is the static phase error between the two clock sources. Jumping between two clock sources to simulate the worst case of clock edge jump (3 ns) from graphical controllers. Cycle-to-cycle jitter at TxCLK out pin should be measured cross V_{CC} range with 100mV noise (V_{CC} noise frequency $< 2\text{MHz}$).

FIGURE 19.

Physical Dimensions inches (millimeters) unless otherwise noted

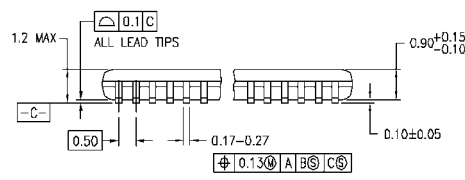
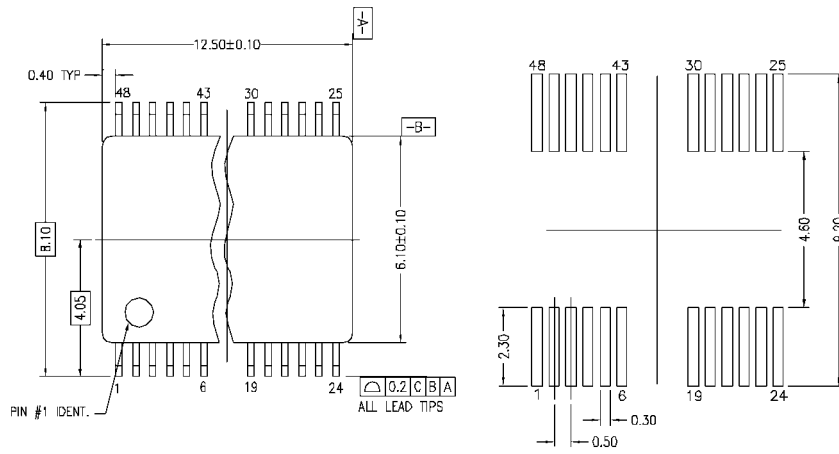

DIMENSIONS ARE IN MILLIMETERS

- NOTES:
- A. CONFORMS TO JEDEC REGISTRATION MO-153, VARIATION ED, DATE 4/97.
 - B. DIMENSIONS ARE IN MILLIMETERS.
 - C. DIMENSIONS ARE EXCLUSIVE OF BURRS, MOLD FLASH, AND TIE BAR EXTRUSIONS.
 - D. DIMENSIONS AND TOLERANCES PER ANSI Y14.5M, 1982.

MTD48REV C

48-Lead Thin Shrink Small Outline Package (TSSOP), JEDEC MO-153, 6.1mm Wide Package Number MTD48

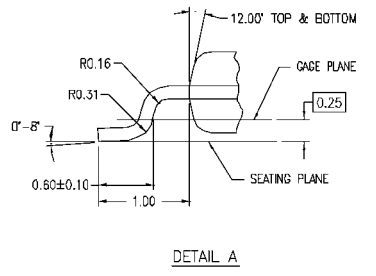

Fairchild does not assume any responsibility for use of any circuitry described, no circuit patent licenses are implied and Fairchild reserves the right at any time without notice to change said circuitry and specifications.

LIFE SUPPORT POLICY

FAIRCHILD'S PRODUCTS ARE NOT AUTHORIZED FOR USE AS CRITICAL COMPONENTS IN LIFE SUPPORT DEVICES OR SYSTEMS WITHOUT THE EXPRESS WRITTEN APPROVAL OF THE PRESIDENT OF FAIRCHILD SEMICONDUCTOR CORPORATION. As used herein:

1. Life support devices or systems are devices or systems which, (a) are intended for surgical implant into the body, or (b) support or sustain life, and (c) whose failure to perform when properly used in accordance with instructions for use provided in the labeling, can be reasonably expected to result in a significant injury to the user.
2. A critical component in any component of a life support device or system whose failure to perform can be reasonably expected to cause the failure of the life support device or system, or to affect its safety or effectiveness.

www.fairchildsemi.com