

TOSHIBA CMOS DIGITAL INTEGRATED CIRCUIT SILICON MONOLITHIC

# TC7MET374AFK

## Octal D - type flip - flop with 3 - state output

The TC7MET374A is an advanced high speed CMOS OCTAL FLIP - FLOP with 3 - STATE OUTPUT fabricated with silicon gate C<sup>2</sup>MOS technology.

It achieves the high speed operation similar to equivalent Bipolar Schottky TTL while maintaining the CMOS low power dissipation.

This 8 - bit D - type flip - flop is controlled by a clock input (CK) and a output enable input (OE).

When the OE input is high, the eight outputs are in a high impedance state.

The input voltage are compatible with TTL output voltage.

This device may be used as a level converter for interfacing 3.3V to 5V system.

Input protection and output circuit ensure that 0 to 5.5V can be applied to the input and output\*1 pins without regard to the supply voltage. These structure prevents device destruction due to mismatched supply and input / output voltages such as battery back up, hot board insertion, etc.

\*1: output in off-state

### FEATURES :

- High Speed..... $f_{MAX} = 140\text{MHz}(\text{typ.})$   
at  $V_{CC} = 5\text{V}$
- Low Power Dissipation..... $I_{CC} = 4\mu\text{A}(\text{max})$  at  $T_a = 25^\circ\text{C}$
- Compatible with TTL outputs..... $V_{IL} = 0.8\text{V}(\text{max})$   
 $V_{IH} = 2.0\text{V}(\text{min})$
- Power Down Protection is provided on all inputs and outputs.
- Balanced Propagation Delays..... $t_{pLH} \approx t_{pHL}$
- Low Noise ..... $V_{OLP} = 1.6\text{V}(\text{max})$
- Pin and Function Compatible with the 74 series (74AC / HC / F / ALS / LS etc.) 374 type.

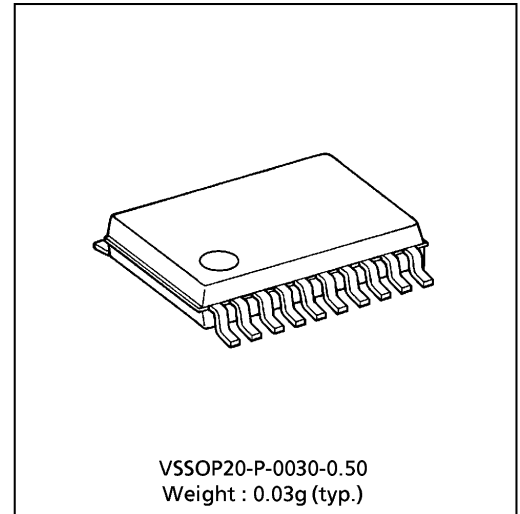

### Pin Assignment

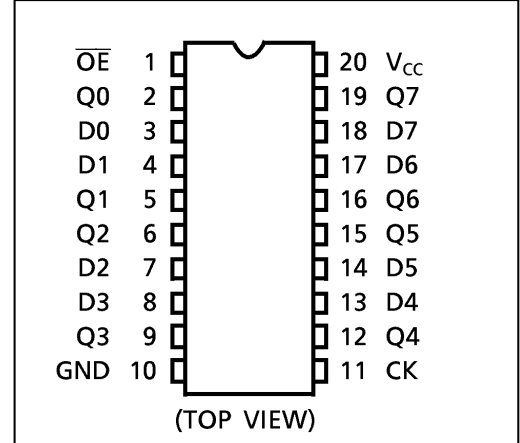

### Truth Table

INPUTS			OUTPUT
OE	CK	D	
H	X	X	Z
L		X	Q <sub>n</sub>
L		L	L
L		H	H

X : Don't Care  
Z : High Impedance  
Q<sub>n</sub> : No Change

### IEC Logic Symbol

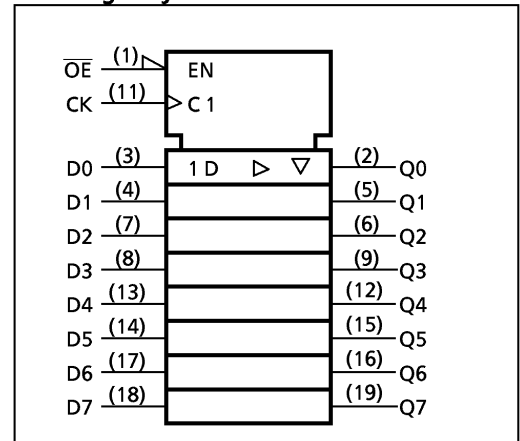

980910EBA2

● TOSHIBA is continually working to improve the quality and the reliability of its products. Nevertheless, semiconductor devices in general can malfunction or fail due to their inherent electrical sensitivity and vulnerability to physical stress. It is the responsibility of the buyer, when utilizing TOSHIBA products, to observe standards of safety, and to avoid situations in which a malfunction or failure of a TOSHIBA product could cause loss of human life, bodily injury or damage to property. In developing your designs, please ensure that TOSHIBA products are used within specified operating ranges as set forth in the most recent products specifications. Also, please keep in mind the precautions and conditions set forth in the TOSHIBA Semiconductor Reliability Handbook.

System Diagram

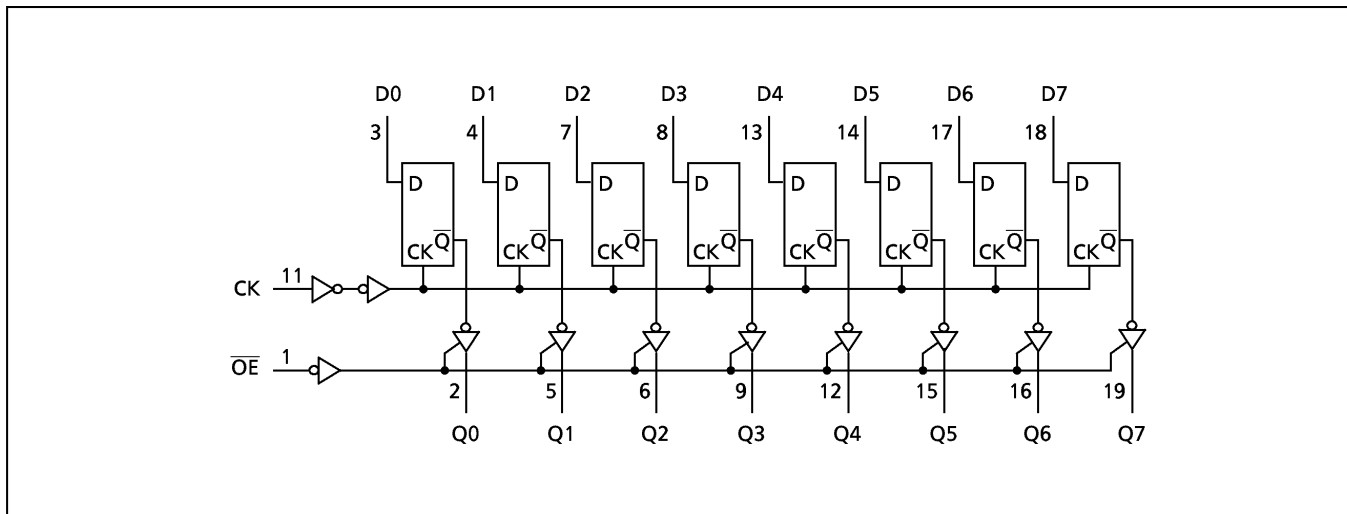

Absolute Maximum Ratings

PARAMETER	SYMBOL	VALUE	UNIT
Supply Voltage Range	$V_{CC}$	-0.5~7.0	V
DC Input Voltage	$V_{IN}$	-0.5~7.0	V
DC Output Voltage	$V_{OUT}$	-0.5~7.0 (Note 1)	V
		-0.5~ $V_{CC} + 0.5$ (Note 2)	
Input Diode Current	$I_{IK}$	-20	mA
Output Diode Current	$I_{OK}$	±20 (Note 3)	mA
DC Output Current	$I_{OUT}$	±25	mA
DC Vcc/Ground Current	$I_{CC}$	±75	mA
Power Dissipation	$P_D$	180	mW
Storage Temperature	$T_{stg}$	-65~150	°C

(Note 1): Output in Off-State

(Note 2): High or Low State.  $I_{OUT}$  absolute maximum rating must be observed.

(Note 3):  $V_{OUT} < GND, V_{OUT} > V_{CC}$

Recommended Operating Conditions

PARAMETER	SYMBOL	VALUE	UNIT
Supply Voltage	$V_{CC}$	4.5~5.5	V
Input Voltage	$V_{IN}$	0~5.5	V
Output Voltage	$V_{OUT}$	0~5.5 (Note 4)	V
		0~ $V_{CC}$ (Note 5)	
Operating Temperature	$T_{opr}$	-40~85	°C
Input Rise and Fall Time	$dt/dV$	0~20	ns/V

(Note 4): Output in Off-State

(Note 5): High or Low State

980910EBA2'

- The products described in this document are subject to the foreign exchange and foreign trade laws.
- The information contained herein is presented only as a guide for the applications of our products. No responsibility is assumed by TOSHIBA CORPORATION for any infringements of intellectual property or other rights of the third parties which may result from its use. No license is granted by implication or otherwise under any intellectual property or other rights of TOSHIBA CORPORATION or others.
- The information contained herein is subject to change without notice.

## DC Electrical Characteristics

PARAMETER	SYMBOL	CONDITON		V <sub>CC</sub> (V)	Ta = 25°C			Ta = -40~85°C		UNIT
					Min	Typ.	Max	Min	Max	
High - Level Input Voltage	V <sub>IH</sub>			4.5~5.5	2.0	—	—	2.0	—	V
Low - Level Input Voltage	V <sub>IL</sub>			4.5~5.5	—	—	0.8	—	0.8	V
High - Level Output Voltage	V <sub>OH</sub>	V <sub>IN</sub> = V <sub>IH</sub> or V <sub>IL</sub>	I <sub>OH</sub> = -50μA	4.5	4.40	4.50	—	4.40	—	V
			I <sub>OH</sub> = -8mA	4.5	3.94	—	—	3.80	—	V
Low - Level Output Voltage	V <sub>OL</sub>	V <sub>IN</sub> = V <sub>IH</sub> or V <sub>IL</sub>	I <sub>OL</sub> = 50μA	4.5	—	0.0	0.10	—	0.10	V
			I <sub>OL</sub> = 8mA	4.5	—	—	0.36	—	0.44	V
3 - State Output Off - State Current	I <sub>OZ</sub>	V <sub>IN</sub> = V <sub>IH</sub> or V <sub>IL</sub> V <sub>OUT</sub> = V <sub>CC</sub> or GND		5.5	—	—	±0.25	—	±2.50	μA
Input Leakage Current	I <sub>IN</sub>	V <sub>IN</sub> = 5.5V or GND		0~5.5	—	—	±0.1	—	±1.0	
Quiescent Supply Current	I <sub>CC</sub>	V <sub>IN</sub> = V <sub>CC</sub> or GND		5.5	—	—	4.0	—	40.0	
	I <sub>CCT</sub>	PER INPUT : V <sub>IN</sub> = 3.4V OTHER INPUT : V <sub>CC</sub> or GND		5.5	—	—	1.35	—	1.50	mA
Output Leakage Current	I <sub>OPD</sub>	V <sub>OUT</sub> = 5.5V		0	—	—	+0.5	—	+5.0	μA

Timing Requirements (Input t<sub>r</sub> = t<sub>f</sub> = 3ns)

PARAMETER	SYMBOL	TEST CONDITION	V <sub>CC</sub> (V)	Ta = 25°C		Ta = -40~85°C	UNIT
				Typ .	Limit	Limit	
Minimum Pulse Width (CK)	t <sub>W(H)</sub> t <sub>W(L)</sub>		5.0 ± 0.5	—	6.5	8.5	ns
Minimum Set - up Time	t <sub>s</sub>		5.0 ± 0.5	—	2.5	2.5	
Minimum Hold Time	t <sub>h</sub>		5.0 ± 0.5	—	2.5	2.5	

AC Electrical Characteristics (Input  $t_r = t_f = 3ns$ )

PARAMETER	SYMBOL	TEST CONDITION	Ta = 25°C			Ta = -40~85°C		UNIT		
			V <sub>CC</sub> (V)	CL (pF)	Min	Typ.	Max		Min	Max
Propagation Delay Time (CK-Q)	t <sub>pLH</sub> t <sub>pHL</sub>		5.0 ± 0.5	15	—	4.1	9.4	1.0	10.5	ns
				50	—	5.6	10.4	1.0	11.5	
3-State Output Enable Time	t <sub>pZL</sub> t <sub>pZH</sub>	RL = 1kΩ	5.0 ± 0.5	15	—	6.5	10.2	1.0	11.5	
				50	—	7.3	11.2	1.0	12.5	
3-State Output Disable Time	t <sub>pLZ</sub> t <sub>pHZ</sub>	RL = 1kΩ	5.0 ± 0.5	50	—	7.0	11.2	1.0	12.0	
Maximum Clock Frequency	f <sub>MAX</sub>		5.0 ± 0.5	15	90	140	—	80	—	MHz
				50	85	130	—	95	—	
Output to Output Skew	t <sub>osLH</sub> t <sub>osHL</sub>	(Note 6)	5.0 ± 0.5	50	—	—	1.0	—	1.0	ns
Input Capacitance	C <sub>IN</sub>				—	4	10	—	10	pF
Output Capacitance	C <sub>OUT</sub>				—	9	—	—	—	
Power Dissipation Capacitance	C <sub>PD</sub>	(Note 7)			—	25	—	—	—	

(Note 6): Parameter guaranteed by design.  $t_{osLH} = |t_{pLHm} - t_{pLHn}|$ ,  $t_{osHL} = |t_{pHLm} - t_{pHLn}|$

(Note 7): C<sub>PD</sub> is defined as the value of the internal equivalent capacitance which is calculated from the operating current consumption without load.

Average operating current can be obtained by the equation:

$$I_{CC(oper.)} = C_{PD} \cdot V_{CC} \cdot f_{IN} + I_{CC}/8 \text{ (per F/F)}$$

And the total C<sub>PD</sub> when n pcs. of Latch operate can be gained by the following equation:

$$C_{PD} \text{ (total)} = 14 + 11 \cdot n$$

Noise Characteristics (Input  $t_r = t_f = 3ns$ )

PARAMETER	SYMBOL	TEST CONDITION	Ta = 25°C			UNIT
			V <sub>CC</sub> (V)	Typ.	Limit	
Quiet Output Maximum Dynamic V <sub>OL</sub>	V <sub>OLP</sub>	C <sub>L</sub> = 50pF	5.0	1.1	1.5	V
Quiet Output Minimum Dynamic V <sub>OL</sub>	V <sub>OLV</sub>	C <sub>L</sub> = 50pF	5.0	-1.1	-1.5	V
Minimum High Level Dynamic Input Voltage	V <sub>IHD</sub>	C <sub>L</sub> = 50pF	5.0	—	3.5	V
Maximum Low Level Dynamic Input Voltage	V <sub>ILD</sub>	C <sub>L</sub> = 50pF	5.0	—	1.5	V

PACKAGE DIMENSIONS (VSSOP20-P-0030-0.50)

Unit in mm

