

24-bit 192kHz Stereo DAC

DESCRIPTION

The WM8726 is a high performance stereo DAC designed for audio applications such as DVD, home theatre systems, and digital TV. The WM8726 supports data input word lengths from 16 to 24-bits and sampling rates up to 192kHz. The WM8726 consists of a serial interface port, digital interpolation filters, multi-bit sigma delta modulators and stereo DAC in a 14-lead SOIC package.

The WM8726 has a hardware control interface for selection of audio data interface format, mute and de-emphasis. The WM8726 supports I²S, right Justified or DSP interfaces.

The WM8726 is an ideal device to interface to AC-3™, DTS™, and MPEG audio decoders for surround sound applications, or for use in DVD players, including supporting the implementation of 2 channels at 192kHz for high-end DVD-Audio applications.

FEATURES

- Stereo DAC
- Audio Performance
 - 100dB SNR ('A' weighted @ 48kHz)
 - -88dB THD
- DAC Sampling Frequency: 8kHz – 192kHz
- Pin Selectable Audio Data Interface Format
 - I²S, 16-bit Right Justified or DSP
- 2.7V - 5.5V Supply Operation
- 14-lead SOIC Package
- Pin Compatible with WM8725

APPLICATIONS

- DVD Players
- Home Theatre Systems
- Digital TV
- Digital Set Top Boxes

BLOCK DIAGRAM

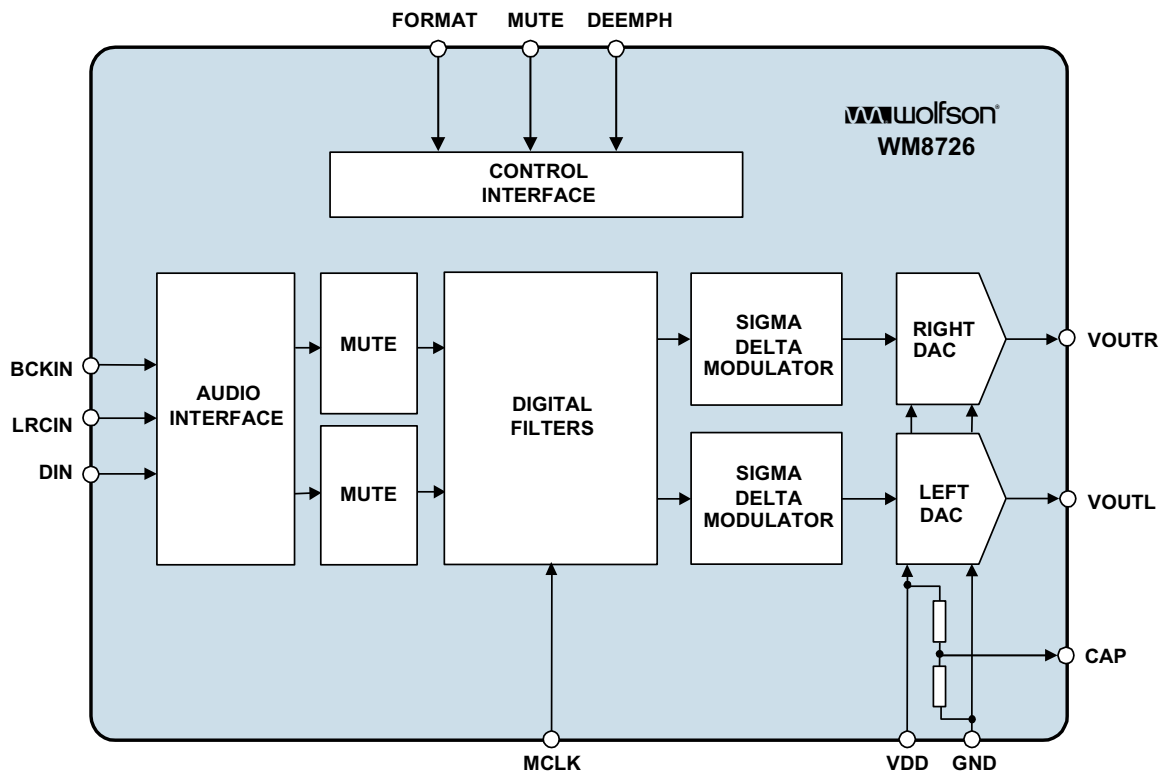
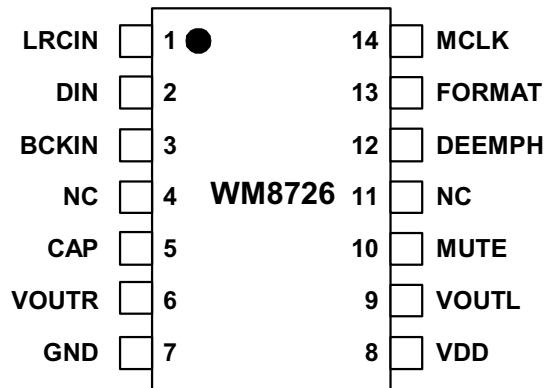

TABLE OF CONTENTS

DESCRIPTION	1
FEATURES.....	1
APPLICATIONS	1
BLOCK DIAGRAM	1
TABLE OF CONTENTS	2
PIN CONFIGURATION.....	3
ORDERING INFORMATION	3
PIN DESCRIPTION	4
ABSOLUTE MAXIMUM RATINGS.....	5
DC ELECTRICAL CHARACTERISTICS	6
ELECTRICAL CHARACTERISTICS	6
TERMINOLOGY	7
MASTER CLOCK TIMING	8
DIGITAL AUDIO INTERFACE	8
DEVICE DESCRIPTION	9
GENERAL INTRODUCTION	9
DAC CIRCUIT DESCRIPTION	9
CLOCKING SCHEMES	10
DIGITAL AUDIO INTERFACE	10
AUDIO DATA SAMPLING RATES.....	12
HARDWARE CONTROL MODES	13
DIGITAL FILTER CHARACTERISTICS	15
DAC FILTER RESPONSES.....	15
DIGITAL DE-EMPHASIS CHARACTERISTICS.....	16
APPLICATIONS INFORMATION	17
RECOMMENDED EXTERNAL COMPONENTS	17
RECOMMENDED EXTERNAL COMPONENTS VALUES	17
RECOMMENDED ANALOGUE LOW PASS FILTER	18
PCB LAYOUT RECOMMENDATIONS	18
PACKAGE DRAWING.....	19
IMPORTANT NOTICE	20
ADDRESS:.....	20

PIN CONFIGURATION



ORDERING INFORMATION

DEVICE	TEMPERATURE RANGE	PACKAGE	MOISTURE SENSITIVITY LEVEL	PEAK SOLDERING TEMPERATURE
WM8726GED/V	-25 to +85°C	14-lead SOIC (Pb-free)	MSL2	260°C
WM8726GED/RV	-25 to +85°C	14-lead SOIC (Pb-free, tape and reel)	MSL2	260°C

Notes:

Reel quantity = 3,000

PIN DESCRIPTION

PIN	NAME	TYPE	DESCRIPTION
1	LRCIN	Digital input	Sample rate clock input
2	DIN	Digital input	Serial audio data input
3	BCKIN	Digital input	Bit clock input
4	NC	No connect	No internal connection
5	CAP	Analogue output	Analogue internal reference
6	VOUTR	Analogue output	Right channel DAC output
7	GND	Supply	Negative supply
8	VDD	Supply	Positive supply
9	VOUTL	Analogue output	Left channel DAC output
10	MUTE	Digital input	Soft mute control, Internal pull down High Impedance = Automute High = Mute ON Low = Mute OFF
11	NC	No connect	No internal connection
12	DEEMPH	Digital input	De-emphasis select, Internal pull up High = de-emphasis ON Low = de-emphasis OFF
13	FORMAT	Digital input	Data input format select, Internal pull up Low = 16-bit right justified or DSP 'late' High = 16-24-bit I ² S or DSP 'early'
14	MCLK	Digital input	Master clock input

Note:

1. Digital input pins have Schmitt trigger input buffers.

ABSOLUTE MAXIMUM RATINGS

Absolute Maximum Ratings are stress ratings only. Permanent damage to the device may be caused by continuously operating at or beyond these limits. Device functional operating limits and guaranteed performance specifications are given under Electrical Characteristics at the test conditions specified.



ESD Sensitive Device. This device is manufactured on a CMOS process. It is therefore generically susceptible to damage from excessive static voltages. Proper ESD precautions must be taken during handling and storage of this device.

Wolfson tests its package types according to IPC/JEDEC J-STD-020B for Moisture Sensitivity to determine acceptable storage conditions prior to surface mount assembly. These levels are:

MSL1 = unlimited floor life at <30°C / 85% Relative Humidity. Not normally stored in moisture barrier bag.

MSL2 = out of bag storage for 1 year at <30°C / 60% Relative Humidity. Supplied in moisture barrier bag.

MSL3 = out of bag storage for 168 hours at <30°C / 60% Relative Humidity. Supplied in moisture barrier bag.

The Moisture Sensitivity Level for each package type is specified in Ordering Information.

CONDITION	MIN	MAX
Supply voltage	-0.3V	+7V
Voltage range digital inputs	GND -0.3V	VDD +0.3V
Master Clock Frequency		50MHz
Operating temperature range, T _A	-25°C	+85°C
Storage temperature after soldering	-65°C	+150°C

DC ELECTRICAL CHARACTERISTICS

PARAMETER	SYMBOL	TEST CONDITIONS	MIN	TYP	MAX	UNIT
Supply range	VDD		2.7		5.5	V
Ground	GND			0		V
Supply current		VDD = 5V		27		mA
Supply current		VDD = 3.3V		23		mA
Power down current (note 4)		VDD=3.3V		0.5		mA

ELECTRICAL CHARACTERISTICS**Test Conditions**

VDD = 5V, GND = 0V, T_A = +25°C, fs = 48kHz, MCLK = 256fs unless otherwise stated.

PARAMETER	SYMBOL	TEST CONDITIONS	MIN	TYP	MAX	UNIT
Digital Logic Levels (TTL Levels)						
Input LOW level	V _{IL}				0.8	V
Input HIGH level	V _{IH}		2.0			V
Output LOW	V _{OL}	I _{OL} = 2mA			GND + 0.3V	V
Output HIGH	V _{OH}	I _{OH} = 2mA	VDD - 0.3V			V
Analogue Reference Levels						
Reference voltage (CAP)				VDD/2		V
Potential divider resistance	R _{CAP}	VDD to CAP and CAP to GND		50k		Ω
DAC Output (Load = 10kΩ 50pF)						
0dBfs Full scale output voltage		At DAC outputs		1.1 x VDD/5		V _{rms}
SNR (Note 1,2,3)		A-weighted, @ fs = 48kHz	90	100		dB
SNR (Note 1,2,3)		A-weighted @ fs = 96kHz		97		dB
SNR (Note 1,2,3)		A-weighted @ fs = 192kHz		97		dB
SNR (Note 1,2,3)		A-weighted, @ fs = 48kHz VDD = 3.3V		95		dB
SNR (Note 1,2,3)		A-weighted @ fs = 96kHz VDD = 3.3V		95		dB
SNR (Note 1,2,3)		Non 'A' weighted @ fs = 48kHz		98		dB
THD (Note 3)		1kHz, 0dBfs		-88		dB
Dynamic Range (Note 2)		1kHz, THD+N @ -60dBfs	90	100		dB
DAC channel separation				93		dB

Test ConditionsVDD = 5V, GND = 0V, T_A = +25°C, f_s = 48kHz, MCLK = 256fs unless otherwise stated.

PARAMETER	SYMBOL	TEST CONDITIONS	MIN	TYP	MAX	UNIT
Analogue Output Levels						
Output level		Load = 10kΩ, 0dBFS		1.1		V _{RMS}
		Load = 10kΩ, 0dBFS, (VDD = 3.3V)		0.72		V _{RMS}
Gain mismatch channel-to-channel				±1		%FSR
Minimum resistance load		To midrail or a.c. coupled		1		kΩ
		To midrail or a.c. coupled (VDD = 3.3V)		1		kΩ
Maximum capacitance load		5V or 3.3V		100		pF
Output d.c. level				VDD/2		V
Power On Reset (POR)						
POR threshold				1.8		V

Notes:

- Ratio of output level with 1kHz full scale input, to the output level with all zeros into the digital input, measured 'A' weighted over a 20Hz to 20kHz bandwidth.
- All performance measurements done with 20kHz low pass filter, and where noted an A-weight filter. Failure to use such a filter will result in higher THD+N and lower SNR and Dynamic Range readings than are found in the Electrical Characteristics. The low pass filter removes out of band noise; although it is not audible it may affect dynamic specification values.
- CAP pin decoupled with 10uF and 0.1uF capacitors (smaller values may result in reduced performance).
- Power down occurs 1.5μs after MCLK is stopped.

TERMINOLOGY

- Signal-to-noise ratio (dB) - SNR is a measure of the difference in level between the full scale output and the output with no signal applied. (No Auto-zero or Automute function is employed in achieving these results).
- Dynamic range (dB) - DNR is a measure of the difference between the highest and lowest portions of a signal. Normally a THD+N measurement at 60dB below full scale. The measured signal is then corrected by adding the 60dB to it. (e.g. THD+N @ -60dB= -32dB, DR= 92dB).
- THD+N (dB) - THD+N is a ratio, of the rms values, of (Noise + Distortion)/Signal.
- Stop band attenuation (dB) - Is the degree to which the frequency spectrum is attenuated (outside audio band).
- Channel Separation (dB) - Also known as Cross-Talk. This is a measure of the amount one channel is isolated from the other. Normally measured by sending a full scale signal down one channel and measuring the other.

MASTER CLOCK TIMING

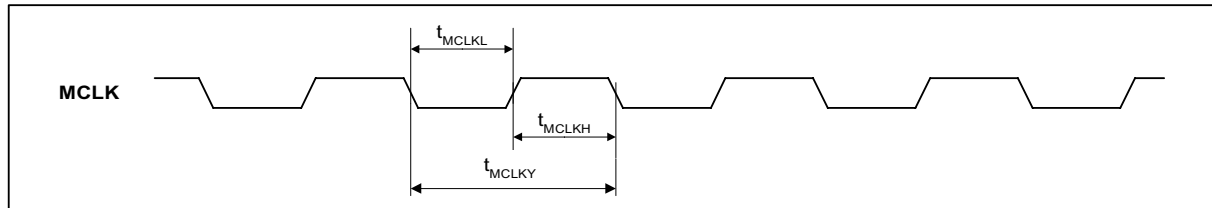

Figure 1 Master Clock Timing Requirements

Test Conditions

VDD = 5V, GND = 0V, $T_A = +25^\circ\text{C}$, $f_s = 48\text{kHz}$, MCLK = 256fs unless otherwise stated.

PARAMETER	SYMBOL	TEST CONDITIONS	MIN	TYP	MAX	UNIT
System Clock Timing Information						
MCLK Master clock pulse width high	t_{MCLKH}		8			ns
MCLK Master clock pulse width low	t_{MCLKL}		8			ns
MCLK Master clock cycle time	t_{MCLKY}		20			ns
MCLK Duty cycle			40:60		60:40	
Time from MCLK stopping to power down.			1.5		12	μs

DIGITAL AUDIO INTERFACE

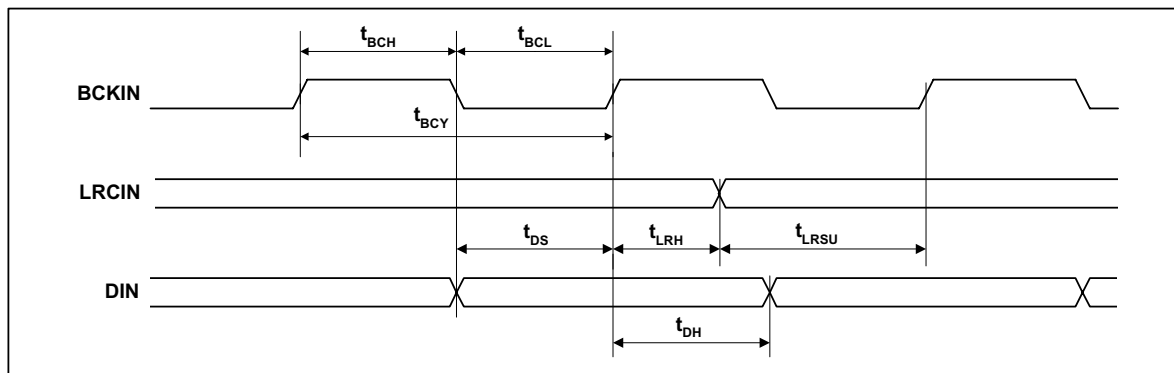

Figure 2 Digital Audio Data Timing

Test Conditions

VDD = 5V, GND = 0V, $T_A = +25^\circ\text{C}$, $f_s = 48\text{kHz}$, MCLK = 256fs unless otherwise stated.

PARAMETER	SYMBOL	TEST CONDITIONS	MIN	TYP	MAX	UNIT
Audio Data Input Timing Information						
BCKIN cycle time	t_{BCY}		40			ns
BCKIN pulse width high	t_{BCH}		16			ns
BCKIN pulse width low	t_{BCL}		16			ns
LRCIN set-up time to BCKIN rising edge	t_{LRSU}		8			ns
LRCIN hold time from BCKIN rising edge	t_{LRH}		8			ns
DIN set-up time to BCKIN rising edge	t_{DS}		8			ns
DIN hold time from BCKIN rising edge	t_{DH}		8			ns

DEVICE DESCRIPTION

GENERAL INTRODUCTION

The WM8726 is a high performance DAC designed for digital consumer audio applications. The range of features make it ideally suited for use in DVD players, AV receivers and other consumer audio equipment.

The WM8726 is a complete 2-channel stereo audio digital-to-analogue converter, including digital interpolation filter, multi-bit sigma delta with dither, and switched capacitor multi-bit stereo DAC and output smoothing filters. It is fully compatible and an ideal partner for a range of industry standard microprocessors, controllers and DSPs. A novel multi bit sigma-delta DAC design is used, utilising a 128x oversampling rate, to optimise signal to noise performance and offer increased clock jitter tolerance. (In 'high-rate' operation, the oversampling ratio is 64x for system clocks of 128fs or 192fs)

Control of internal functionality of the device is provided by hardware control (pin programmed).

Operation using master clocks of 256fs, 384fs, 512fs or 768fs is provided, selection between clock rates being automatically controlled. Sample rates (fs) from less than 8kHz to 96kHz are allowed, provided the appropriate system clock is input. Support is also provided for up to 192kHz using a master clock of 128fs or 192fs.

The audio data interface supports 16-bit right justified or 16-24-bit I²S (Philips left justified, one bit delayed) interface formats. A DSP interface is also supported, enhancing the interface options for the user.

A single 2.7-5.5V supply may be used, the output amplitude scaling with absolute supply level. Low supply voltage operation and low current consumption combined with the low pin count small package make the WM8726 attractive for many consumer applications.

The device is packaged in a small 14-pin SOIC.

DAC CIRCUIT DESCRIPTION

The WM8726 DAC is designed to allow playback of 24-bit PCM audio or similar data with high resolution and low noise and distortion. Sample rates up to 192kHz may be used, with much lower sample rates acceptable provided that the ratio of sample rate (LRCIN) to master clock (MCLK) is maintained at one of the required rates.

The two DACs on the WM8726 are implemented using sigma-delta oversampled conversion techniques. These require that the PCM samples are digitally filtered and interpolated to generate a set of samples at a much higher rate than the up to 192kHz input rate. This sample stream is then digitally modulated to generate a digital pulse stream that is then converted to analogue signals in a switched capacitor DAC. The advantage of this technique is that the DAC is linearised using noise shaping techniques, allowing the 24-bit resolution to be met using non-critical analogue components. A further advantage is that the high sample rate at the DAC output means that smoothing filters on the output of the DAC need only have fairly crude characteristics in order to remove the characteristic steps, or images on the output of the DAC. To ensure that generation of tones characteristic to sigma-delta convertors is not a problem, dithering is used in the digital modulator along with a higher order modulator. The multi-bit switched capacitor technique used in the DAC reduces sensitivity to clock jitter, and dramatically reduces out of band noise compared to switched current or single bit techniques used in other implementations.

The voltage on the CAP pin is used as the reference for the DACs. Therefore the amplitude of the signals at the DAC outputs will scale with the amplitude of the voltage at the CAP pin. An external reference could be used to drive into the CAP pin if desired, with a value typically of about midrail ideal for optimum performance.

The outputs of the 2 DACs are buffered out of the device by buffer amplifiers. These amplifiers will source load currents of several mA and sink current up to 1.5mA allowing significant loads to be driven. The output source is active and the sink is Class A, i.e. fixed value, so greater loads might be driven if an external 'pull-down' resistor is connected at the output.

Typically an external low pass filter circuit will be used to remove residual out of band noise characteristic of delta sigma converters. However, the advanced multi-bit DAC used in WM8726 produces far less out of band noise than single bit traditional sigma delta DACs, and so in many applications this filter may be removed, or replaced with a simple RC pole.

CLOCKING SCHEMES

In a typical digital audio system there is only one central clock source producing a reference clock to which all audio data processing is synchronised. This clock is often referred to as the audio system's Master Clock. The external master clock can be applied directly through the MCLK input pin with no configuration necessary for sample rate selection.

Note that on the WM8726, MCLK is used to derive clocks for the DAC path. The DAC path consists of DAC sampling clock, DAC digital filter clock and DAC digital audio interface timing. In a system where there are a number of possible sources for the reference clock it is recommended that the clock source with the lowest jitter be used to optimise the performance of the DAC.

The device can be powered down by stopping MCLK. In this state the power consumption is substantially reduced.

DIGITAL AUDIO INTERFACE

Audio data is applied to the internal DAC filters via the Digital Audio Interface. Three interface formats are supported:

- Right Justified mode
- I²S mode
- DSP mode

All formats send the MSB first. The data format is selected with the FORMAT pin. When FORMAT is LOW, right justified data format is selected and word lengths up to 16-bits may be used. When the FORMAT pin is HIGH, I²S format is selected and word length of any value up to 24-bits may be used. (If a word length shorter than 24-bits is used, the unused bits will be padded with zeros). If LRCIN is 4 BCKINs or less duration, the DSP compatible format is selected. Early and Late clock formats are supported, selected by the state of the FORMAT pin.

'Packed' mode (i.e. only 32 or 48 clocks per LRCIN period) operation is also supported in both I²S (16-24 bits) and right justified formats, (16 bit). If a 'packed' format of 16-bit word length is applied (16 BCKINs per LRCIN half period), the device auto-detects this mode and switches to 16-bit data length.

I²S MODE

The WM8726 supports word lengths of 16-24 bits in I²S mode.

In I²S mode, the digital audio interface receives data on the DIN input. Audio Data is time multiplexed with LRCIN indicating whether the left or right channel is present. LRCIN is also used as a timing reference to indicate the beginning or end of the data words.

In I²S modes, the minimum number of BCKINs per LRCIN period is 2 times the selected word length. LRCIN must be high for a minimum of word length BCKINs and low for a minimum of word length BCKINs. Any mark to space ratio on LRCIN is acceptable provided the above requirements are met. In I²S mode, the MSB is sampled on the second rising edge of BCKIN following a LRCIN transition. LRCIN is low during the left samples and high during the right samples.

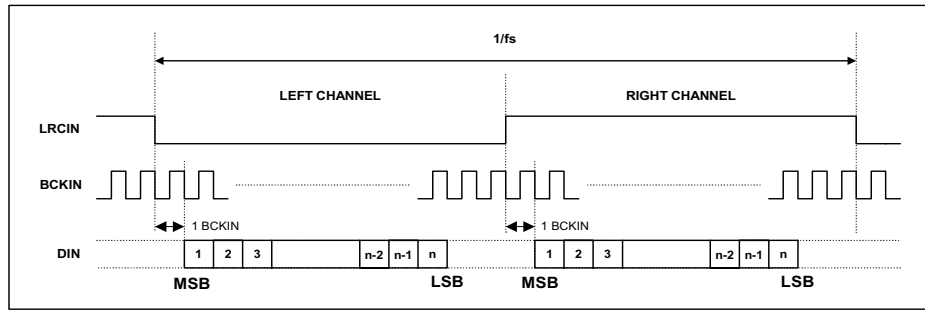

Figure 3 I²S Mode Timing Diagram

RIGHT JUSTIFIED MODE

The WM8726 supports word lengths of 16-bits in right justified mode.

In right justified mode, the digital audio interface receives data on the DIN input. Audio Data is time multiplexed with LRCIN indicating whether the left or right channel is present. LRCIN is also used as a timing reference to indicate the beginning or end of the data words.

In right justified mode, the minimum number of BCKINs per LRCIN period is 2 times the selected word length. LRCIN must be high for a minimum of word length BCKINs and low for a minimum of word length BCKINs. Any mark to space ratio on LRCIN is acceptable provided the above requirements are met.

In right justified mode, the LSB is sampled on the rising edge of BCKIN preceding a LRCIN transition. LRCIN is high during the left samples and low during the right samples.

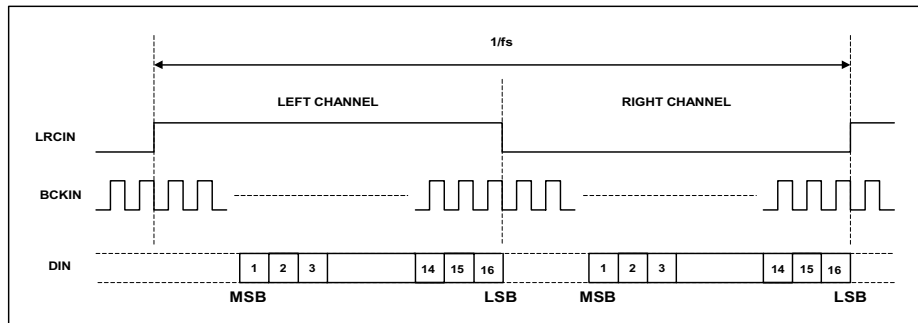

Figure 4 Right Justified Mode Timing Diagram

DSP MODE

A DSP compatible, time division multiplexed format is also supported by the WM8726. This format is of the type where a 'synch' pulse is followed by two data words (left and right) of predetermined word length. (16-bits). The 'synch' pulse replaces the normal duration LRCIN, and DSP mode is auto-detected by the shorter than normal duration of the LRCIN. If LRCIN is of 4 BCKIN or less duration, the DSP compatible format is selected. Mode A and Mode B clock formats are supported, selected by the state of the FORMAT pin.

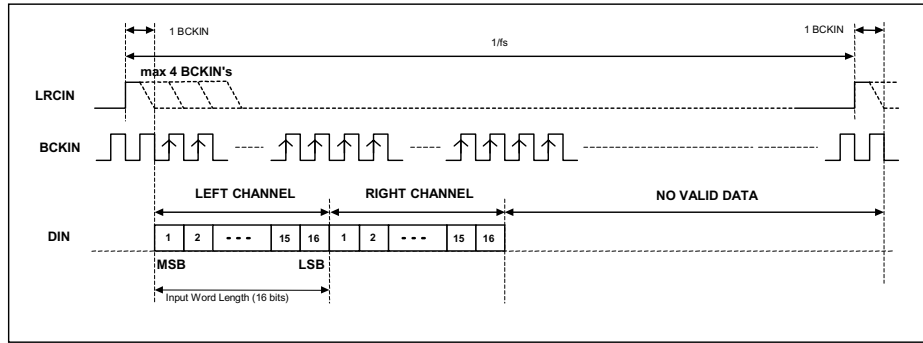

Figure 5 DSP Mode A Timing

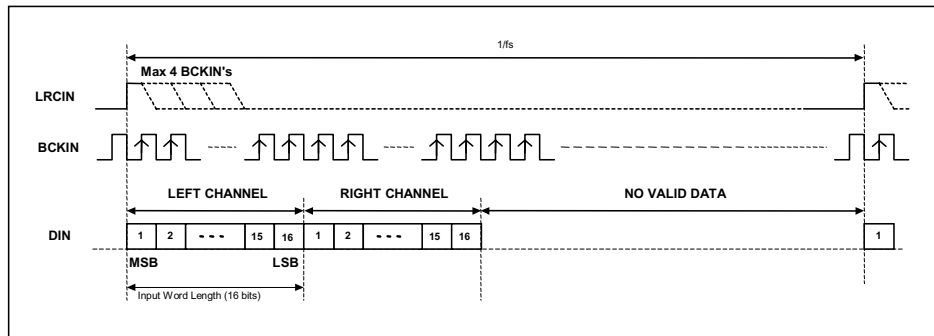

Figure 6 DSP Mode B Timing

AUDIO DATA SAMPLING RATES

The master clock for WM8726 supports audio sampling rates from 128fs to 768fs, where fs is the audio sampling frequency (LRCIN) typically 32kHz, 44.1kHz, 48kHz, 96kHz or 192kHz. The master clock is used to operate the digital filters and the noise shaping circuits.

The WM8726 has a master clock detection circuit that automatically determines the relation between the master clock frequency and the sampling rate (to within +/- 8 master clocks). If there is a greater than 8 clocks error, the interface shuts down the DAC and mutes the output. The master clock should be synchronised with LRCIN, although the WM8726 is tolerant of phase differences or jitter on this clock.

SAMPLING RATE (LRCIN)	MASTER CLOCK FREQUENCY (MHZ) (MCLK)					
	128fs	192fs	256fs	384fs	512fs	768fs
32kHz	4.096	6.144	8.192	12.288	16.384	24.576
44.1kHz	5.6448	8.467	11.2896	16.9344	22.5792	33.8688
48kHz	6.144	9.216	12.288	18.432	24.576	36.864
96kHz	12.288	18.432	24.576	36.864	Unavailable	Unavailable
192kHz	24.576	36.864	Unavailable	Unavailable	Unavailable	Unavailable

Table 1 Master Clock Frequencies Versus Sampling Rate

HARDWARE CONTROL MODES

The WM8726 is hardware programmable providing the user with options to select input audio data format, de-emphasis and mute.

MUTE AND AUTO MUTE OPERATION

Pin 10 (MUTE) controls selection of MUTE directly, and can be used to enable and disable the automute function, or as an output of the automuted signal.

MUTE PIN	DESCRIPTION
0	Normal Operation, MUTE off
1	Mute DAC channels
Floating	Enable IZD, MUTE becomes an output to indicate when IZD occurs.

Table 2 Mute and Automute Control

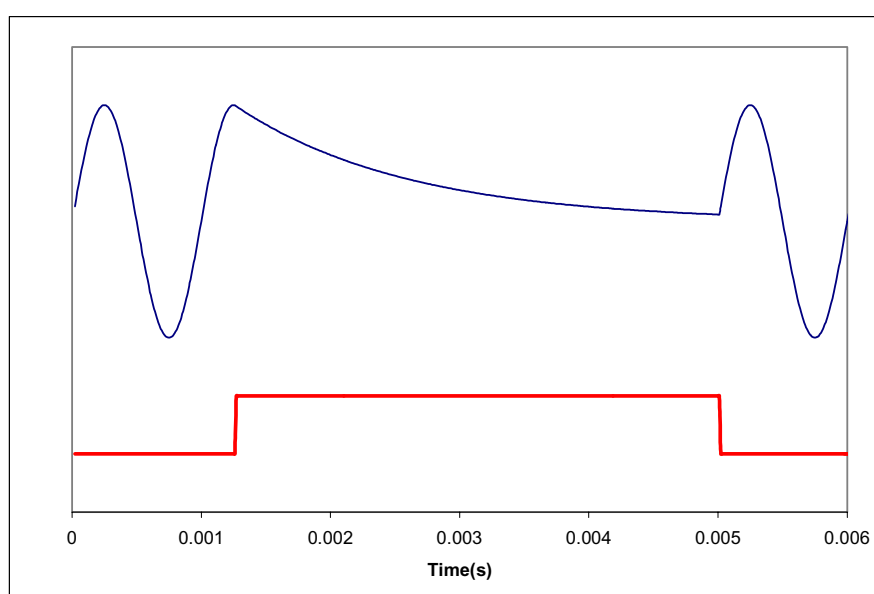

Figure 7 Application and Release of MUTE

The MUTE pin is an input to select mute or not mute. MUTE is active high; taking the pin high causes the filters to soft mute, ramping down the audio signal over a few milliseconds. Taking MUTE low again allows data into the filter. Refer to Figure 7.

The Infinite Zero Detect (IZD) function detects a series of zero value audio samples of 1024 samples long being applied to both channels. After such an event, a latch is set whose output (AUTOMUTED) is connected through a 10kohm resistor to the MUTE pin. Thus if the MUTE pin is not being driven, the automute function will assert mute.

If MUTE is tied low, AUTOMUTED is overridden and will not mute. If MUTE is driven from a bi-directional source, then both MUTE and automute functions are available. If MUTE is not driven, AUTOMUTED appears as a weak output (10k source impedance) so can be used to drive external mute circuits. AUTOMUTED will be removed as soon as any channel receives a non-zero input.

A diagram showing how the various Mute modes interact is shown below in Figure 8.

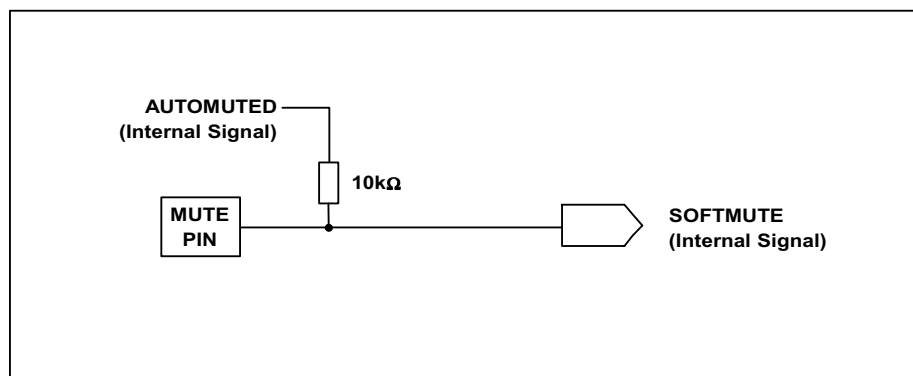

Figure 8 Selection Logic for MUTE Modes

INPUT AUDIO FORMAT SELECTION

FORMAT (pin 13) controls the data input format.

FORMAT	INPUT DATA MODE
0	16 bit right justified
1	16–24 bit I ² S

Table 3 Input Audio Format Selection

Notes:

1. In 16-24 bit I²S mode, any data from 16-24 bits or more is supported provided that LRCIN is high for a minimum of data width BCKINs and low for a minimum of data width BCKINs, unless Note 2. For data widths greater than 24 bits, the LSB's will be truncated and the most significant 24 bits will be used by the internal processing.
2. If exactly 16 BCKIN cycles occur in both the low and high period of LRCIN the WM8726 will assume the data is 16-bit and accept the data accordingly.

INPUT DSP FORMAT SELECTION

FORMAT	50% LRCIN DUTY CYCLE	LRCIN of 4 BCKIN or Less Duration
0	16 bit (MSB-first, right justified)	DSP format – 'late' mode
1	I ² S format up to 24 bit (Philips serial data protocol)	DSP format – 'early' mode

Table 4 DSP Interface Formats

DE-EMPHASIS CONTROL

DEM (pin 12) is an input control for selection of de-emphasis filtering to be applied.

DEEMPH	DE-EMPHASIS
0	Off
1	On

Table 5 De-emphasis Control

DIGITAL FILTER CHARACTERISTICS

PARAMETER	SYMBOL	TEST CONDITIONS	MIN	TYP	MAX	UNIT
Passband Edge		-3dB		0.487fs		
Passband Ripple		$f < 0.444fs$			± 0.05	dB
Stopband Attenuation		$f > 0.555fs$	-60			dB

Table 6 Digital Filter Characteristics

DAC FILTER RESPONSES

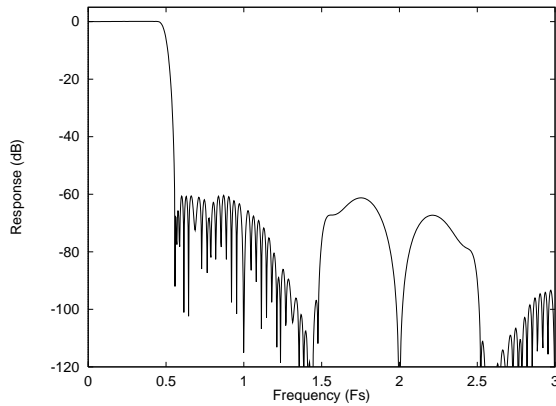

Figure 9 DAC Digital Filter Frequency Response
-44.1, 48 and 96kHz

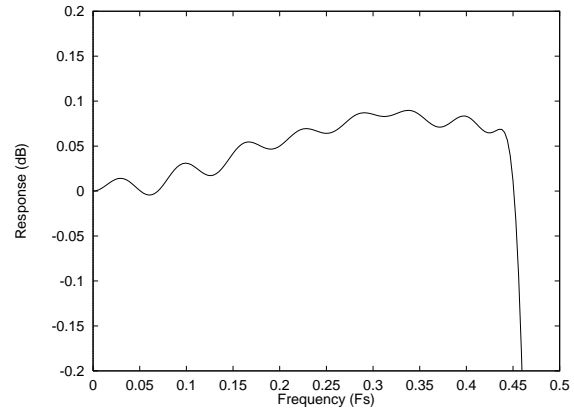

Figure 10 DAC Digital Filter Ripple
-44.1, 48 and 96kHz

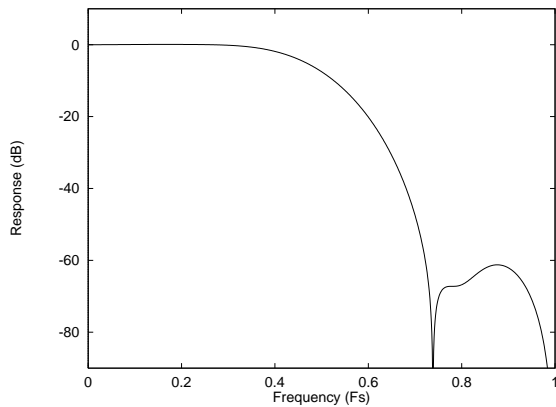

Figure 11 DAC Digital Filter Frequency Response -192kHz

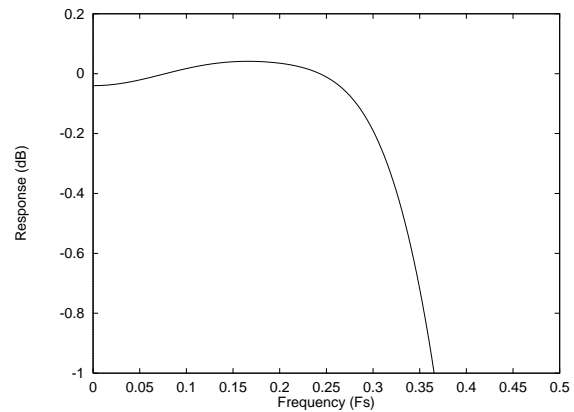

Figure 12 DAC Digital Filter Ripple -192kHz

DIGITAL DE-EMPHASIS CHARACTERISTICS

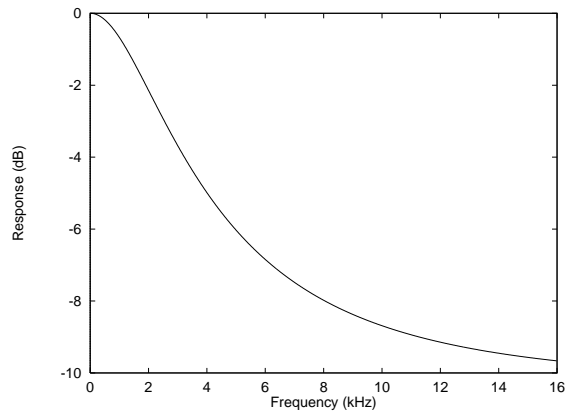

Figure 13 De-Emphasis Frequency Response (32kHz)

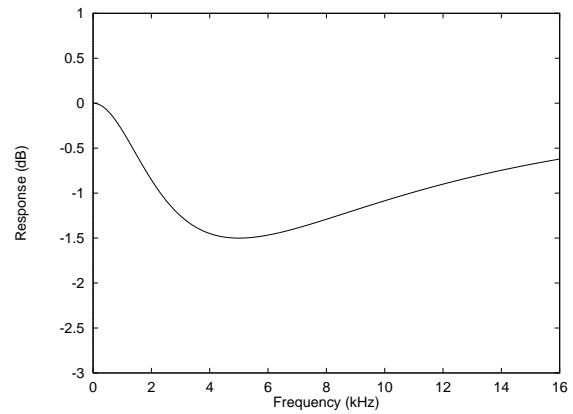

Figure 14 De-Emphasis Error (32kHz)

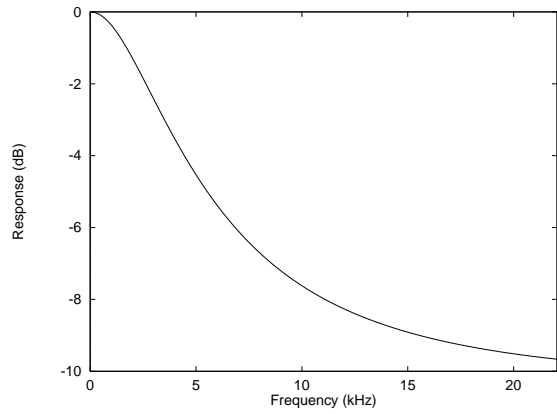

Figure 15 De-Emphasis Frequency Response (44.1kHz)

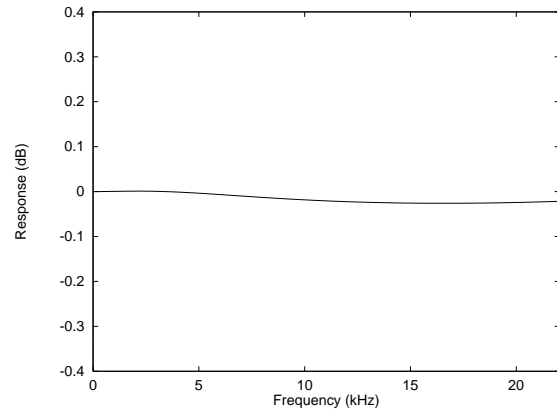

Figure 16 De-Emphasis Error (44.1kHz)

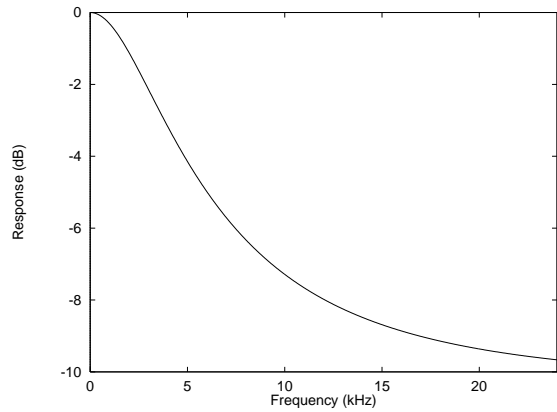

Figure 17 De-Emphasis Frequency Response (48kHz)

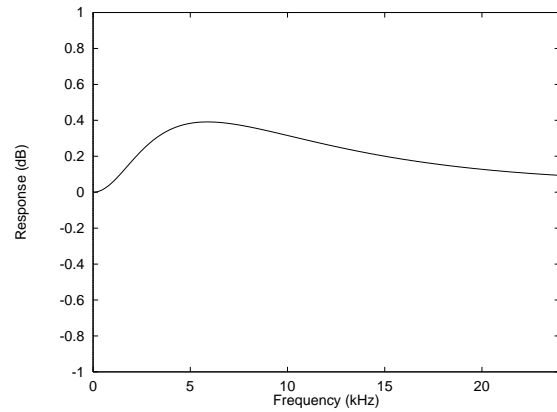

Figure 18 De-Emphasis Error (48kHz)

APPLICATIONS INFORMATION

RECOMMENDED EXTERNAL COMPONENTS

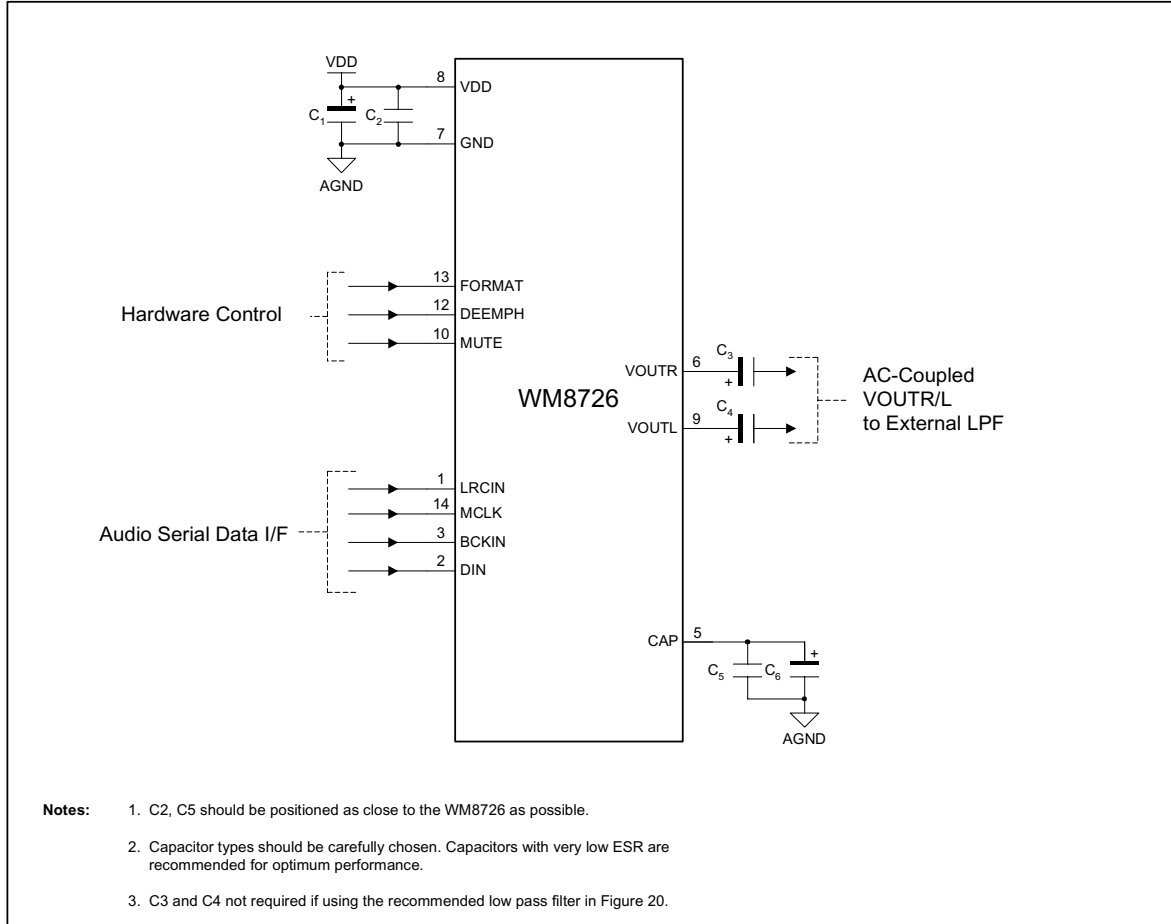

Figure 19 External Component Diagram

RECOMMENDED EXTERNAL COMPONENTS VALUES

COMPONENT REFERENCE	SUGGESTED VALUE	DESCRIPTION
C1	10 μ F	De-coupling for VDD
C2	0.1 μ F	De-coupling for VDD
C3 and C4	10 μ F	Output AC coupling caps to remove midrail DC level from outputs
C5	0.1 μ F	Reference de-coupling capacitors for CAP pin
C6	10 μ F	

Table 7 External Components Description

RECOMMENDED ANALOGUE LOW PASS FILTER

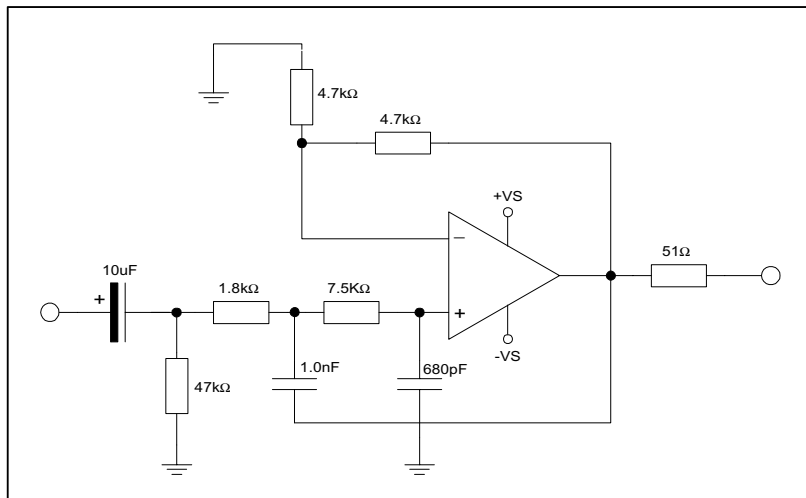

Figure 20 Recommended 2nd Order Low Pass Filter

An external low pass filter is recommended (see Figure 20) if the device is driving a wideband amplifier. In some applications, a passive RC filter may be adequate.

PCB LAYOUT RECOMMENDATIONS

Care should be taken in the layout of the PCB that the WM8726 is to be mounted to. The following notes will help in this respect:

1. **The VDD supply to the device should be as noise free as possible.** This can be accomplished to a large degree with a 10uF bulk capacitor placed locally to the device and a 0.1uF high frequency decoupling capacitor placed as close to the VDD pin as possible. It is best to place the 0.1uF capacitor directly between the VDD and GND pins of the device on the same layer to minimize track inductance and thus improve device decoupling effectiveness.
2. **The CAP pin should be as noise free as possible.** This pin provides the decoupling for the on chip reference circuits and thus any noise present on this pin will be directly coupled to the device outputs. In a similar manner to the VDD decoupling described in 1. above, this pin should be decoupled with a 10uF bulk capacitor local to the device and a 0.1uF capacitor as close to the CAP pin as possible.
3. **Separate analogue and digital track routing from each other.** The device is split into analogue (pins 5 – 9) and digital (pins 1 – 4 & pins 10 – 14) sections that allow the routing of these signals to be easily separated. By physically separating analogue and digital signals, crosstalk from the PCB can be minimized.
4. **Use an unbroken solid GND plane.** To achieve best performance from the device, it is advisable to have either a GND plane layer on a multilayer PCB or to dedicate one side of a 2 layer PCB to be a GND plane. For double sided implementations it is best to route as many signals as possible on the device mounted side of the board, with the opposite side acting as a GND plane. The use of a GND plane greatly reduces any electrical emissions from the PCB and minimizes crosstalk between signals.

An evaluation board is available for the WM8726 that demonstrates the above techniques and the excellent performance achievable from the device. This can be ordered or the User manual downloaded from the Wolfson web site at www.wolfsonmicro.com

PACKAGE DRAWING

D: 14 PIN SOIC 3.9mm Wide Body

DM001.C

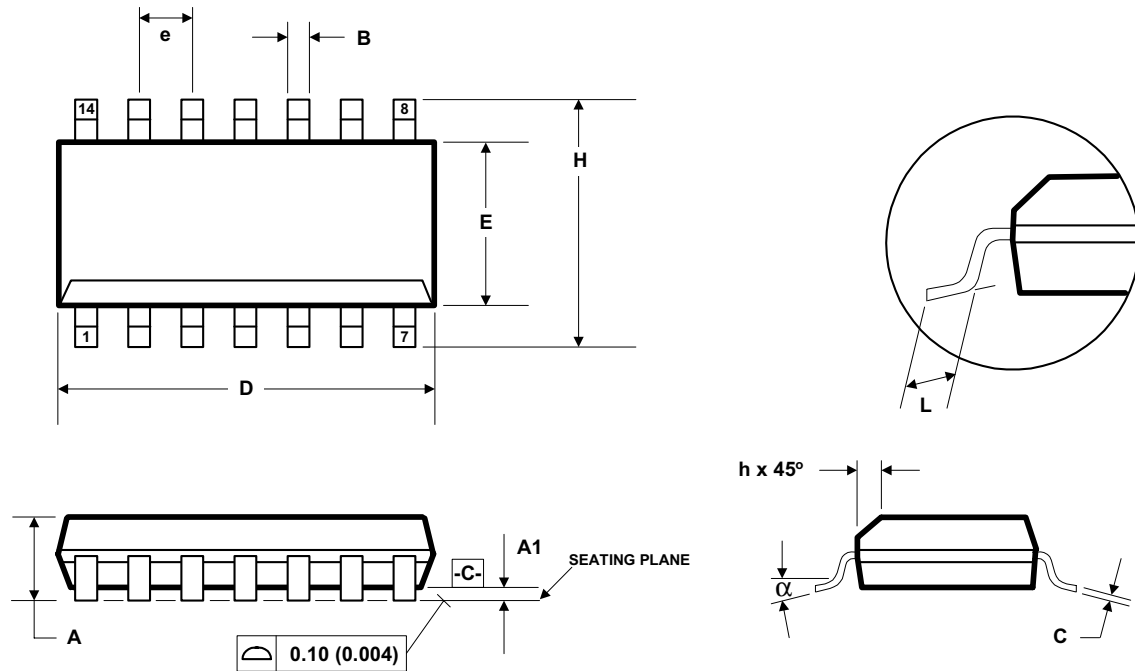

Symbols	Dimensions (mm)		Dimensions (Inches)	
	MIN	MAX	MIN	MAX
A	1.35	1.75	0.0532	0.0688
A1	0.10	0.25	0.0040	0.0098
B	0.33	0.51	0.0130	0.0200
C	0.19	0.25	0.0075	0.0098
D	8.55	8.75	0.3367	0.3444
E	3.80	4.00	0.1497	0.1574
e	1.27 BSC		0.05 BSC	
H	5.80	6.20	0.2284	0.2440
h	0.25	0.50	0.0099	0.0196
L	0.40	1.27	0.0160	0.0500
α	0°	8°	0°	8°
REF:	JEDEC.95, MS-012			

- NOTES:
 A. ALL LINEAR DIMENSIONS ARE IN MILLIMETERS (INCHES).
 B. THIS DRAWING IS SUBJECT TO CHANGE WITHOUT NOTICE.
 C. BODY DIMENSIONS DO NOT INCLUDE MOLD FLASH OR PROTRUSION, NOT TO EXCEED 0.25MM (0.010IN).
 D. MEETS JEDEC.95 MS-012, VARIATION = AB. REFER TO THIS SPECIFICATION FOR FURTHER DETAILS.

IMPORTANT NOTICE

Wolfson Microelectronics plc (WM) reserve the right to make changes to their products or to discontinue any product or service without notice, and advise customers to obtain the latest version of relevant information to verify, before placing orders, that information being relied on is current. All products are sold subject to the WM terms and conditions of sale supplied at the time of order acknowledgement, including those pertaining to warranty, patent infringement, and limitation of liability.

WM warrants performance of its products to the specifications applicable at the time of sale in accordance with WM's standard warranty. Testing and other quality control techniques are utilised to the extent WM deems necessary to support this warranty. Specific testing of all parameters of each device is not necessarily performed, except those mandated by government requirements.

In order to minimise risks associated with customer applications, adequate design and operating safeguards must be used by the customer to minimise inherent or procedural hazards. Wolfson products are not authorised for use as critical components in life support devices or systems without the express written approval of an officer of the company. Life support devices or systems are devices or systems that are intended for surgical implant into the body, or support or sustain life, and whose failure to perform when properly used in accordance with instructions for use provided, can be reasonably expected to result in a significant injury to the user. A critical component is any component of a life support device or system whose failure to perform can be reasonably expected to cause the failure of the life support device or system, or to affect its safety or effectiveness.

WM assumes no liability for applications assistance or customer product design. WM does not warrant or represent that any license, either express or implied, is granted under any patent right, copyright, mask work right, or other intellectual property right of WM covering or relating to any combination, machine, or process in which such products or services might be or are used. WM's publication of information regarding any third party's products or services does not constitute WM's approval, license, warranty or endorsement thereof.

Reproduction of information from the WM web site or datasheets is permissible only if reproduction is without alteration and is accompanied by all associated warranties, conditions, limitations and notices. Representation or reproduction of this information with alteration voids all warranties provided for an associated WM product or service, is an unfair and deceptive business practice, and WM is not responsible nor liable for any such use.

Resale of WM's products or services with statements different from or beyond the parameters stated by WM for that product or service voids all express and any implied warranties for the associated WM product or service, is an unfair and deceptive business practice, and WM is not responsible nor liable for any such use.

ADDRESS:

Wolfson Microelectronics plc
Westfield House
26 Westfield Road
Edinburgh
EH11 2QB
United Kingdom

Tel :: +44 (0)131 272 7000

Fax :: +44 (0)131 272 7001

Email :: sales@wolfsonmicro.com