



SANYO Semiconductors

DATA SHEET

LB11683V — Monolithic Digital IC

Three-Phase Sensorless Motor Driver

Overview

The LB11683V is a three-phase full-wave current-linear-drive motor driver IC. It adopts a sensorless control system without the use of a Hall effect device. For quieter operation, the LB11683V features a current soft switching circuit and is optimal for driving the cooling fan motors used in refrigerators, etc.

Functions

- Current linear drive
- Built-in current limiter circuit
- Output stage oversaturation prevention circuit
- Coil counter-electromotive FG output
- Built-in thermal shutdown circuit
- Beat lock prevention circuit
- Lock protection circuit
- Lock detection output

Specifications

Absolute Maximum Ratings at $T_a = 25^\circ\text{C}$

Parameter	Symbol	Conditions	Ratings	Unit
Supply voltage	V_{CC} max		14.5	V
Output applied voltage	V_O max		14.5	V
Input applied voltage	V_I max		-0.3 to $V_{CC}+0.3$	V
Output current	I_O max		1.5	A
Allowable power dissipation	P_d max	Independent IC	0.5	W
Operating temperature	T_{opr}		-30 to +85	$^\circ\text{C}$
Storage temperature	T_{stg}		-55 to +150	$^\circ\text{C}$

■ Any and all SANYO Semiconductor Co.,Ltd. products described or contained herein are, with regard to "standard application", intended for the use as general electronics equipment (home appliances, AV equipment, communication device, office equipment, industrial equipment etc.). The products mentioned herein shall not be intended for use for any "special application" (medical equipment whose purpose is to sustain life, aerospace instrument, nuclear control device, burning appliances, transportation machine, traffic signal system, safety equipment etc.) that shall require extremely high level of reliability and can directly threaten human lives in case of failure or malfunction of the product or may cause harm to human bodies, nor shall they grant any guarantee thereof. If you should intend to use our products for applications outside the standard applications of our customer who is considering such use and/or outside the scope of our intended standard applications, please consult with us prior to the intended use. If there is no consultation or inquiry before the intended use, our customer shall be solely responsible for the use.

■ Specifications of any and all SANYO Semiconductor Co.,Ltd. products described or contained herein stipulate the performance, characteristics, and functions of the described products in the independent state, and are not guarantees of the performance, characteristics, and functions of the described products as mounted in the customer's products or equipment. To verify symptoms and states that cannot be evaluated in an independent device, the customer should always evaluate and test devices mounted in the customer's products or equipment.

SANYO Semiconductor Co., Ltd.

TOKYO OFFICE Tokyo Bldg., 1-10, 1 Chome, Ueno, Taito-ku, TOKYO, 110-8534 JAPAN

LB11683V

Allowable Operating Conditions at $T_a = 25^\circ\text{C}$

Parameter	Symbol	Conditions	Ratings	Unit
Supply voltage 1	V_{CC}	All operating circuits other than internal 5V Reg.	5.5 to 7.0	V
Supply voltage 2	V_{CC}	All operating circuits.	7.0 to 13.8	V

Electrical Characteristics at $T_a = 25^\circ\text{C}$, $V_{CC} = 12\text{V}$

Parameter	Symbol	Conditions	Ratings			Unit
			min	typ	max	
Supply current	I_{CC}	$V_C=V_{CC}$ $V_{FC}=0\text{V}$		10	15	mA
Output saturation voltage 1	V_{OSAT1}	$I_O=0.4\text{A}$, Source+Sink		1.4	2.0	V
Output saturation voltage 2	V_{OSAT2}	$I_O=0.8\text{A}$, Source+Sink, $R_F=0\Omega$		1.8	2.6	V
MCOM pin common-phase input voltage range	VIC		0		$V_{CC}-2$	V
PCOUT output current 1	IPCOU	Source side		-90		μA
PCOUT output current 2	IPCOD	Sink side		90		μA
VCOIN input current	IVCOIN	$V_{COIN}=5\text{V}$		0.1	0.2	μA
VCO minimum frequency	f_{VCOMIN}	$V_{COIN}=\text{open}$ $C_X=0.022\mu\text{F}$	330	400	500	Hz
VCO maximum frequency	f_{VCOMAX}	$V_{COIN}=5\text{V}$ $C_X=0.022\mu\text{F}$	14.8	18.5	22.3	kHz
C1, C2 source current ratio	RSOURCE	$1-(I_{C1SOURCE}/I_{C2SOURCE})$	-12		+12	%
C1, C2 sink current ratio	RSINK	$1-(I_{C1SINK}/I_{C2SINK})$	-12		+12	%
C1 source, sink current ratio	RC1	$I_{C1SOURCE}/I_{C1SINK}$		50		%
C2 source, sink current ratio	RC2	$I_{C2SOURCE}/I_{C2SINK}$		50		%
Counter-electromotive FG output ON voltage	VOL	$I_{FGO}=1\text{mA}$			0.4	V
CT pin charge current	ICT1	Source current	1.2	1.6		μA
CT pin discharge current	ICT2	Sink current	50	77		nA
Lock protection detection voltage	VRD1		2.3	2.45	2.6	V
Lock protection reset voltage	VRD2		1.13	1.26	1.39	V
RD pin leak current	IRDLEAK				10	μA
RD pin output L_O voltage	VRDL	$I_O=1\text{mA}$		100	400	mV
Current limiter setting voltage			0.45	0.5	0.55	V
Thermal shutdown operating temperature	TTSD	Design target *	150	180	210	$^\circ\text{C}$
Thermal shutdown hysteresis	ΔTTSD	Design target *		15		$^\circ\text{C}$

*: Design target value and no measurement is made.

LB11683V

Package Dimensions

unit : mm (typ)

3315

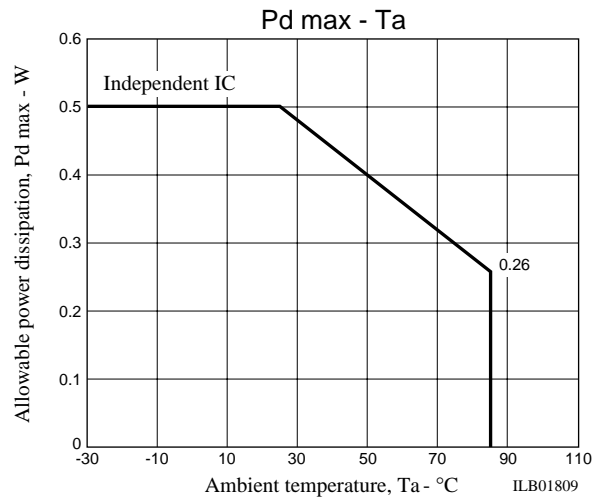
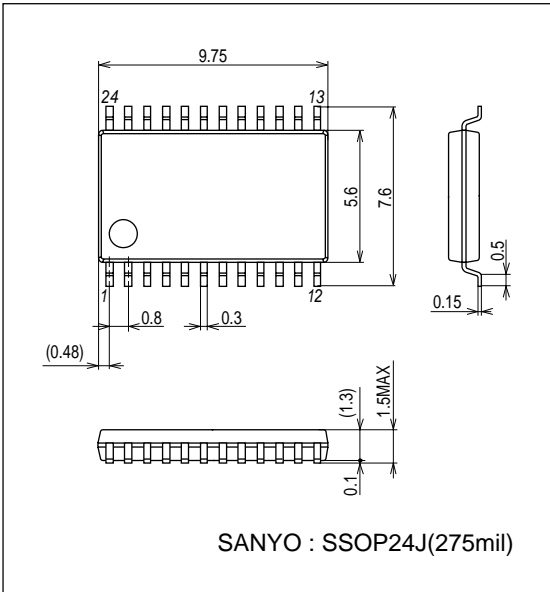

Pin Assignment

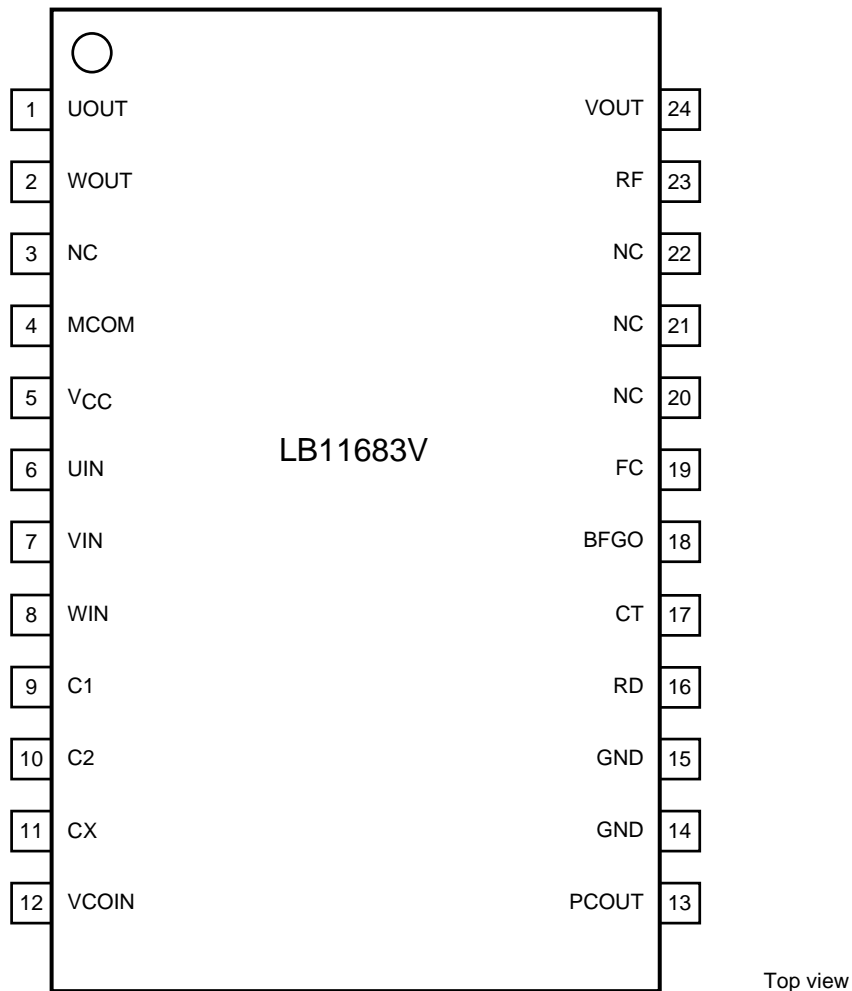

Block Diagram

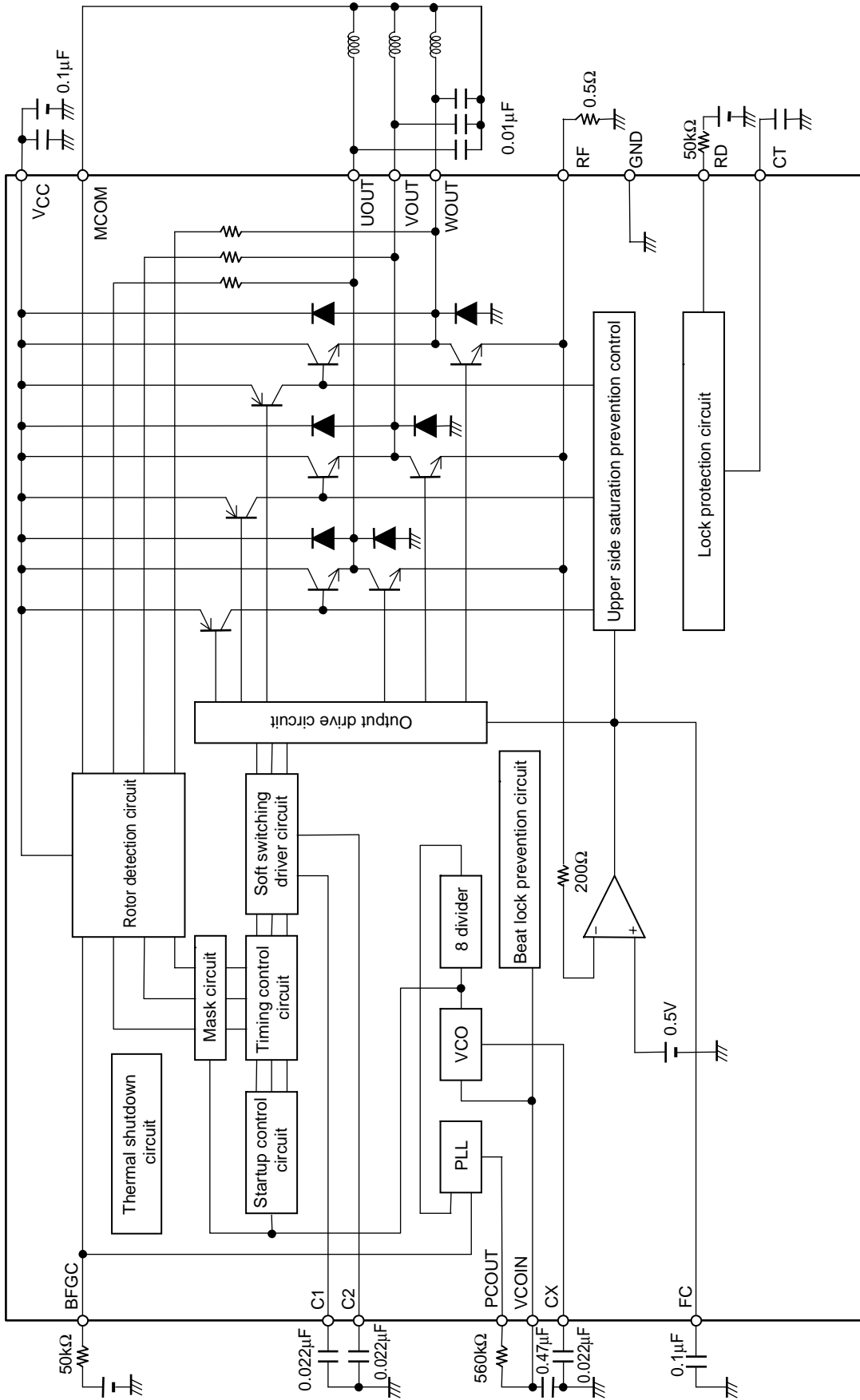

ILB01810

LB11683V

Pin Functions

Pin No.	Symbol	Pin Voltage	Equivalent Circuit Diagram	Description
24	UOUT			3-phase motor driver output
1	VOOUT			<p>Minimum potential of 3-phase motor driver output transistor.</p> <p>Constant current control is made through detection of this voltage. The current limiter also functions by detecting this potential.</p>
2	WOOUT			
23	RF			
5	VCC	8 to 13.8V		Power supply
4	MCOM			Motor coil neutral point input pin. The coil voltage waveform is detected with reference to this voltage.
6	UIN			<p>Coil waveform detection comparator input pin.</p> <p>This pin is connected to each phase output through the internal 10kΩ resistor.</p>
7	VIN			
8	WIN			
9	C1			Triangular wave generating capacitor connection pin. This triangular wave performs soft-switching of the coil output waveforms.
10	C2			
11	CX			In the VCO circuit, the operation frequency range and minimum operation frequency are determined by means of the capacitor value connected this pin and ground.
12	VCOIN			VCO circuit voltage input pin. The PCOUT pin voltage is input via CR filter.

Continued on next page.

LB11683V

Continued from preceding page.

Pin No.	Symbol	Pin Voltage	Equivalent Circuit Diagram	Description
13	PCOUT			VCO circuit PLL output
14 15	GND			Ground for all other than the output transistor
18	BFGO			Motor counter-electromotive voltage detection FG output (single-phase only). Open collector output
19	FC			Frequency characteristics compensation pin. Insertion of a capacitor between this pin and ground stops oscillation of the closed loop of current control system.
16	RD			Lock detection output. When motor is running: low-level When motor is locked: high-level Open collector output
17	CT			Lock protection ON/OFF time setting capacitor connection pin. The capacitor connected between this pin and ground determines the driver ON/OFF time when the motor is locked.

- SANYO Semiconductor Co.,Ltd. assumes no responsibility for equipment failures that result from using products at values that exceed, even momentarily, rated values (such as maximum ratings, operating condition ranges, or other parameters) listed in products specifications of any and all SANYO Semiconductor Co.,Ltd. products described or contained herein.
- SANYO Semiconductor Co.,Ltd. strives to supply high-quality high-reliability products, however, any and all semiconductor products fail or malfunction with some probability. It is possible that these probabilistic failures or malfunction could give rise to accidents or events that could endanger human lives, trouble that could give rise to smoke or fire, or accidents that could cause damage to other property. When designing equipment, adopt safety measures so that these kinds of accidents or events cannot occur. Such measures include but are not limited to protective circuits and error prevention circuits for safe design, redundant design, and structural design.
- In the event that any or all SANYO Semiconductor Co.,Ltd. products described or contained herein are controlled under any of applicable local export control laws and regulations, such products may require the export license from the authorities concerned in accordance with the above law.
- No part of this publication may be reproduced or transmitted in any form or by any means, electronic or mechanical, including photocopying and recording, or any information storage or retrieval system, or otherwise, without the prior written consent of SANYO Semiconductor Co.,Ltd.
- Any and all information described or contained herein are subject to change without notice due to product/technology improvement, etc. When designing equipment, refer to the "Delivery Specification" for the SANYO Semiconductor Co.,Ltd. product that you intend to use.
- Information (including circuit diagrams and circuit parameters) herein is for example only; it is not guaranteed for volume production.
- Upon using the technical information or products described herein, neither warranty nor license shall be granted with regard to intellectual property rights or any other rights of SANYO Semiconductor Co.,Ltd. or any third party. SANYO Semiconductor Co.,Ltd. shall not be liable for any claim or suits with regard to a third party's intellectual property rights which has resulted from the use of the technical information and products mentioned above.

This catalog provides information as of June, 2007. Specifications and information herein are subject to change without notice.