

HITACHI

KAOHSIUNG HITACHI
ELECTRONICS CO.,LTD
P.O. BOX 26-27
2,13TH EAST ST. K.E.P.Z.
KAOHSIUNG TAIWAN R.O.C.
TEL:(07) 8211101(10 LINE)
TELEX:81903 KHE
FAX:(07) 821-5860

FOR MESSRS. _____

DATE. Apr.26.'99

CUSTOMER'S ACCEPTANCE SPECIFICATIONS

SP14Q002-T C O N T E N T S

No.	ITEM	SHEET No.	PAGE
1	COVER	7B64PS 2701-SP14Q002-T-1	1-1/1
2	RECORD OF REVISION	7B64PS 2702-SP14Q002-T-1	2-1/1
3	MECHANICAL DATA	7B64PS 2703-SP14Q002-T-1	3-1/1
4	ABSOLUTE MAXIMUM RATINGS	7B64PS 2704-SP14Q002-T-1	4-1/1
5	ELECTRICAL CHARACTERISTICS	7B64PS 2705-SP14Q002-T-1	5-1/1
6	OPTICAL CHARACTERISTICS	7B64PS 2706-SP14Q002-T-1	6-1/2~2/2
7	BLOCK DIAGRAM	7B64PS 2707-SP14Q002-T-1	7-1/1
8	INTERFACE TIMING	7B64PS 2708-SP14Q002-T-1	8-1/3~3/3
9	DIMENSIONAL OUTLINE	7B63PS 2709-SP14Q002-T-1 7B64PS 2709-SP14Q002-T-1	9-1/2 9-2/2
10	QUALITY STANDARD	7B64PS 2710-SP14Q002-T-1	10-1/3~3/3
11	PRECAUTION IN DESIGN	7B64PS 2711-SP14Q002-T-1	11-1/3~3/3
12	DESIGNATION OF LOT MARK	7B64PS 2712-SP14Q002-T-1	12-1/1
13	PRECAUTION FOR USE	7B64PS 2713-SP14Q002-T-1	13-1/1

* WHEN PRODUCT WILL BE DISCONTINUED , CUSTOMER WILL BE INFORMED BY HITACHI WITH TWELVE MONTHS PRIOR ANNOUNCEMENT.

ACCEPTED BY; _____

PROPOSED BY; M. Shan H.

RECORD OF REVISION

DATE	SHEET No.	SUMMARY

3. GENERAL SPECIFICATIONS

(1) PART NAME	SP14Q002-T
(2) MODULE SIZE	167.0(W)mm×109.0(H)mm×10.0(D)mm(max.)
(3) EFFECTIVE DISPLAY AREA	120 mm min. × 89 mm min
(4) DOT SIZE	0.345(W)min. × 0.345(H)min
(5) DOT PITCH	0.360(W)mm × 0.360(H)mm
(6) NUMBER OF DOTS	320 (W) × 240 (H)
(7) DUTY	1/240
(8) LCD	BLACK / WHITE TYPE (NEGATIVE TYPE) THE UPPER POLARIZER IS ANT-GLARE TYPE THE POTTOM POLARIZER IS TRANSFLECTIVE TYPE
(9) VIEWING DIRECTION	6 O'CLOCK
(10) BACK LIGHT	COLD CATHODE FLUORESCENT LAMP.

4. ABSOLUTE MAXIMUM RATINGS

4.1 ELECTRICAL ABSOLUTE MAXIMUM RATINGS.

VSS=0V:STANDARD

ITEM	SYMBOL	MIN.	MAX.	UNIT	COMMENT
POWER SUPPLY FOR LOGIC	VDD-VSS	0	6	V	
POWER SUPPLY FOR LC DRIVING	VDD-V0	0	27.5	V	
INPUT VOLTAGE	V_i	0.3	VDD+0.3	V	NOTE 1
INPUT CURRENT	I_i	0	1	A	
STATIC ELECTRICITY	-	-	100	-	NOTE 2

NOTE 1. $\overline{\text{DISP-OFF}}$, FRAME , LOAD , CP , D0~D3.

NOTE2. MAKE CERTAINS YOU ARE GROUNDED WHEN HANDLING LCM.

4.2 ENVIRONMENTAL ABSOLUTE MAXIMUM RATINGS.

ITEM	OPERATING		STORAGE		OMMNT
	MIN.	MAX.	MIN.	MAX.	
AMBIENT TEMPERATURE	0°C	50°C NOTE 5	-20°C	60°C	NOTE 2,3
HUMIDITY	NOTE 1		NOTE 1		WITHOUT CONDENSATION
VIBRATION	-	2.45m/s ² (0.25G)	-	11.76m/s ² (1.2G) NOTE 5	NOTE 4
SHOCK	-	29.4m/s ² (3 G)	-	490.0m/s ² (50 G) NOTE 5	XYZ DIRECTIONS
CORROSIVE GAS	NOT ACCEPTABLE		NOT ACCEPTABLE		

NOTE 1 $T_a \leq 40^\circ\text{C}$: 85%RH max.

$T_a > 40^\circ\text{C}$: ABSOLUTE HUMIDITY MUST BE LOWER.
THAN THE HUMIDITY OF 85% RH AT 40°C

NOTE 2 T_a AT $-0^\circ\text{C} < 48\text{HRS}$, AT $60^\circ\text{C} < 168\text{HRS}$.

NOTE 3 BACKGROUND COLOR CHANGES SLIGHTLY DEPENDING ON AMBIENT TEMPERATURE. THE PHENOMENON IS REVERSIBLE.
HIGHER STARTING VOLTAGE OF CFL AND HIGHER LCD DRIVING VOLTAGE ARE NEEDED WHILE OPERATING AT 0°C. THE FILE TIME OF CFL WILL BE REDUCED WHILE OPERATING AT 0°C WILL BE LOWER.

NOTE 4 5Hz~100Hz (EXCEPT RESONALCE FREQUENCY AND X,Y,Z EACH DIRECTION WITHIN 1 HOUR)

NOTE 5 THE MODULE SHOULD OPERATED NORMALLY AFTER FINISH THE TEST.

5. ELECTRICAL CHARACTERISTICS

5.1 ELECTRICAL CHARACTERISTICS

ITEM	SYMBOL	CONDITION	MIN.	TYP.	MAX.	UNIT
POWER SUPPLY VOLTAGE FOR LOGIC	VDD-VSS	-	5.0-5%	5.0	5.0+5%	V
POWER SUPPLY VOLTAGE FOR LC DRIVING	VEE-VSS	-	-23.1	-22.0	-20.9	V
INPUT VOLTAGE NOTE 1	VI	L LEVEL	0.8VDD	-	VDD	V
		H LEVEL	0	-	0.2VDD	V
POWER SUPPLY CURRENT FOR LOGIC NOTE 4	IDD	VDD-VSS=5.0V VDD-V0=-22.0V	-	6.0	-	mA
POWER SUPPLY VOLTAGE FOR LC DROVING NOTE 4	IEE	VDD-VSS=5.0V VDD-V0=-22.0V	-	5.0	-	mA
RECOMMENDED LC DROVONG VOLTAGE NOTE 3	VDD-V0	Ta= 0°C , φ= 0°	-	23.0	-	V
		Ta=25°C , φ= 0°	-	22.0	-	V
		Ta=40°C , φ= 0°	-	21.0	-	V
FRAME FREQUENCY	fFRAME	-	70	75	80	Hz

NOTE 1 $\overline{\text{DISP-OFF}}$, fFRAME , LOAD , CP , D0~D3.

NOTE 2 RECOMMENDED LC DRIVING VOLTAGE FLUCTATE ABOUR +/-1.0V BY EACH MODULE.

NOTE 3 NEED TO MAKE SURE OF FLICKING AND RIPPLING OF DISPLAY WHEN SETTING THE FRAME FREQUENCY IN YOU SET.
TEST PATTERN IS ALL "Q"

NOTE 4 fFRAME=75Hz , D0~D3=0,1,0,1.....
VDD-V0=22.0V , Ta=25°C

5.2 ELECTRICAL CHARACTERISTICS OF BACKLIGHT

ITEM	SYMBOL	MIN.	TYP.	MAX.	UNIT	NOTE
LAMP VOLTAGE	VL	-	300	-	V	Ta=25°C
FREQUENCY	fL	-	70	85	kHz	Ta=25°C
LAMP CURRENT	IL	4	5	6	mA	Ta=25°C
STARTING DISCHARGE COLTAGE	VS	(1000)	-	-	V	Ta=25°C

PLEASE CERTAINLY INFORM HITACHI BEFORE DESIGNING LAMP DRIVE CIRCUIT ACCORDING TO THE ABOVE SPECIFICATIONS.

6. OPTICAL CHARACTERISTICS

6.1 OPTICAL CHARACTERISTICS

Ta=25°C(BACKLIGHT ON)

ITEM	SYMBOL	CONDITIONAL	MIN.	TYP.	MAX.	UNIT	NOTE
VIEWING AREA	$\phi 2-\phi 1$	$K \geq 2.0$	-	40	-	deg	1,2
CONTRAST RATIO	K	$\phi=0^\circ, \theta=0^\circ$	-	(5)	-	-	3
RESPONSE TIME (RISE)	tr	$\phi=0^\circ, \theta=0^\circ$	-	120	-	ms	4
RESPONSE TIME (FALL)	tf	$\phi=0^\circ, \theta=0^\circ$	-	150	-	ms	4

(MEASURE CONDITION BY HITACHI)

NOTE 1. DEFINITION OF θ AND ϕ

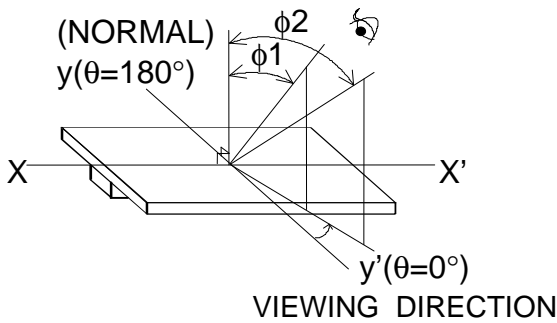

NOTE 3. DEFINITION OF CONTRAST "K"

$$K = \frac{\text{BRIGHTNESS ON SELECTED DOT (B1)}}{\text{BRIGHTNESS ON NON-SELECTED DOT (B2)}}$$

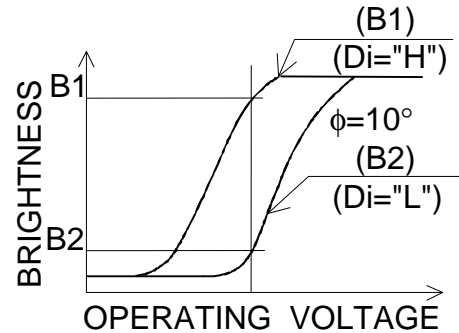

NOTE 2. DEFINITION OF VIEWING ANGLE

$\phi 1$ AND $\phi 2$.

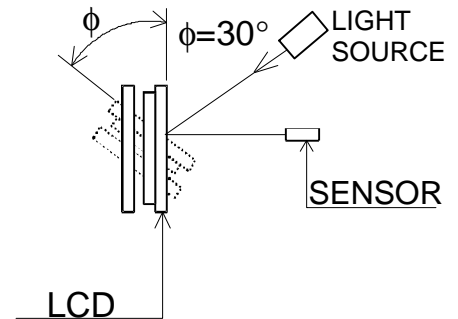
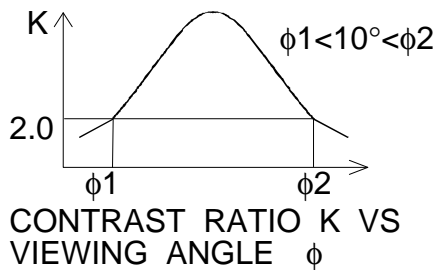

NOTE 4. DEFINITION OF OPTICAL RESPONSE

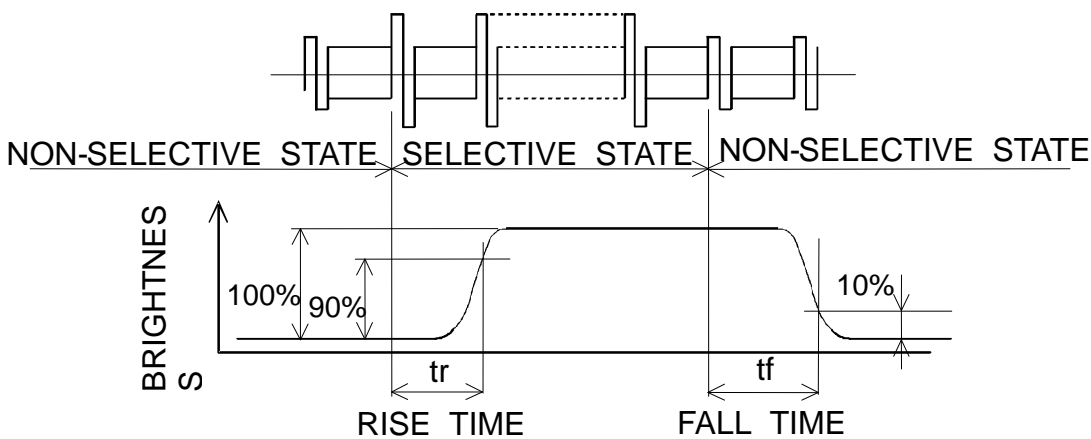

6.2 OPTICAL CHARACTERISTICS OF BACKLIGHT

I T E M	MIN.	TYP.	MAX.	UNIT	NOTE
BRIGHTNESS	-	(10)	-	cd/m ²	IL=5mA NOTE 1,2
RISE TIME	-	5	-	MINUTE	IL=5mA BRIGHTNESS 80%
BRIGHTNESS UNIFORMITY	-	-	+/-30	%	UNDERMENTIONED NOTE 1,3

CFL : INITIAL, Ta=25°C, VDD-V0=22.0V
DISPLAY DATA SHOULD BE ALL "ON".

NOTE 1. MEASUREMENT AFTER 10 MINUTES OF CFL OPERATING.

NOTE 2. BRIGHTNESS CONTROL : 100%

NOTE 3. MEASURE OF THE FOLLOWING 9 PLACES ON THE DISPLAY.
DEFINITION OF THE BRIGHTNESS TOLERANCE.

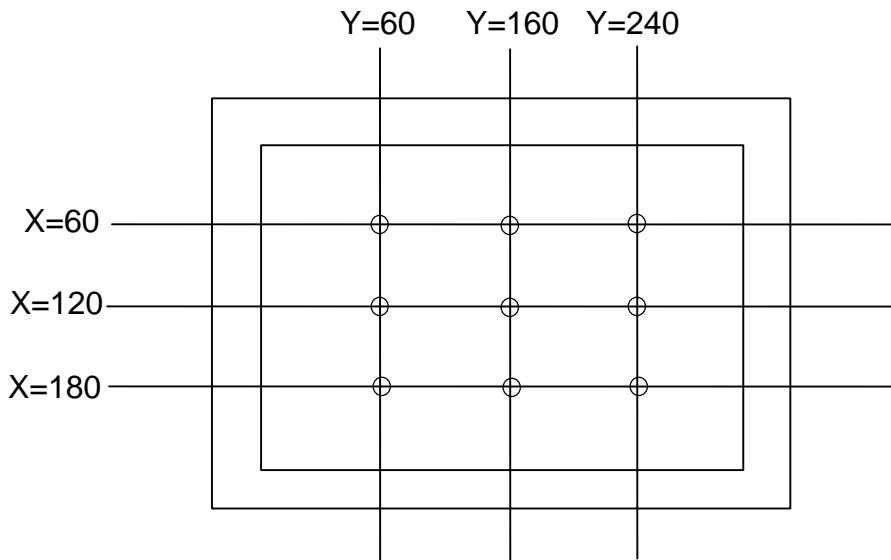

$$\left(\frac{\text{MAX OR MIN BRIGHTNESS} - \text{AVERAGE BRIGHTNESS}}{\text{AVERAGE BRIGHTNESS}} \right) * 100\%$$

7. BLOCK DIAGRAM

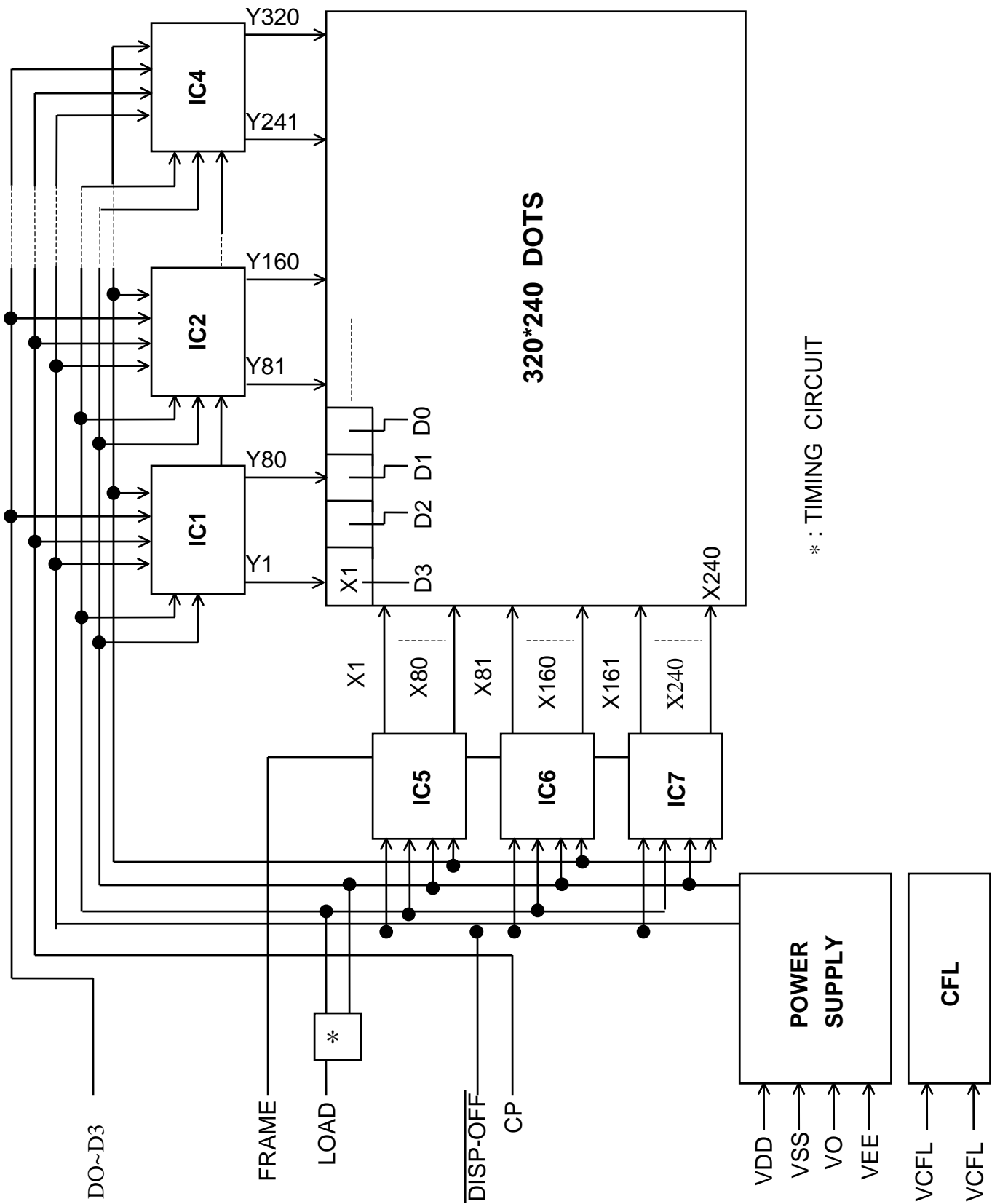

8. INTERFACE TIMING CHART

8.1 INTERFACE TIMING CHART

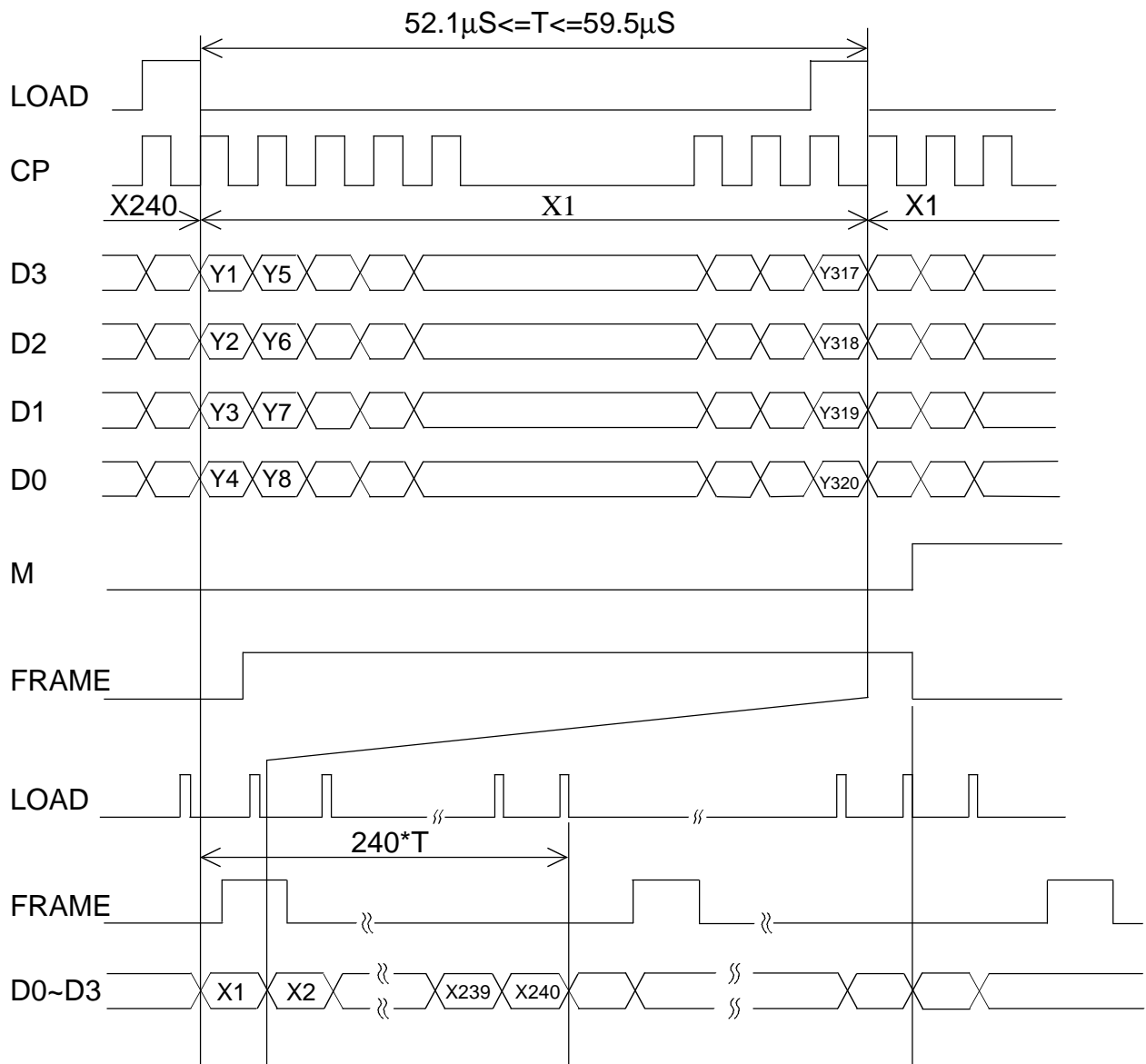

8.2 TIMING CHARACTERISTICS

$0^{\circ}\text{C} \leq T_a = 50^{\circ}\text{C}, V_{DD} = 5.0\text{V} \pm 5\%$

ITEM	SYMBOL	MIN.	TYP.	MAX.	UMIT
CLOCK FREQUENCY	fCP	-	-	6.5	MHz
CLOCK PULSE WIDTH	tW	63	-	-	ns
CLOCK RISE, FALL TIME	tr,tf	-	-	20	ns
DATA SET UP TIME	tDSU	50	-	-	ns
DATA HOLD TIME	tDHD	50	-	-	ns
LOAD SET UP TIME	tLSU	80	-	-	ns
LOAD _ CLOCK TIME	tLC	100	-	-	ns
"FRAME" SET UP TIME	tSETUP	100	-	-	ns
"FRAME" HOLD TIME	tHOLD	100	-	-	ns
"LOAD" PULSE WIDTH	tWC	125	-	-	ns

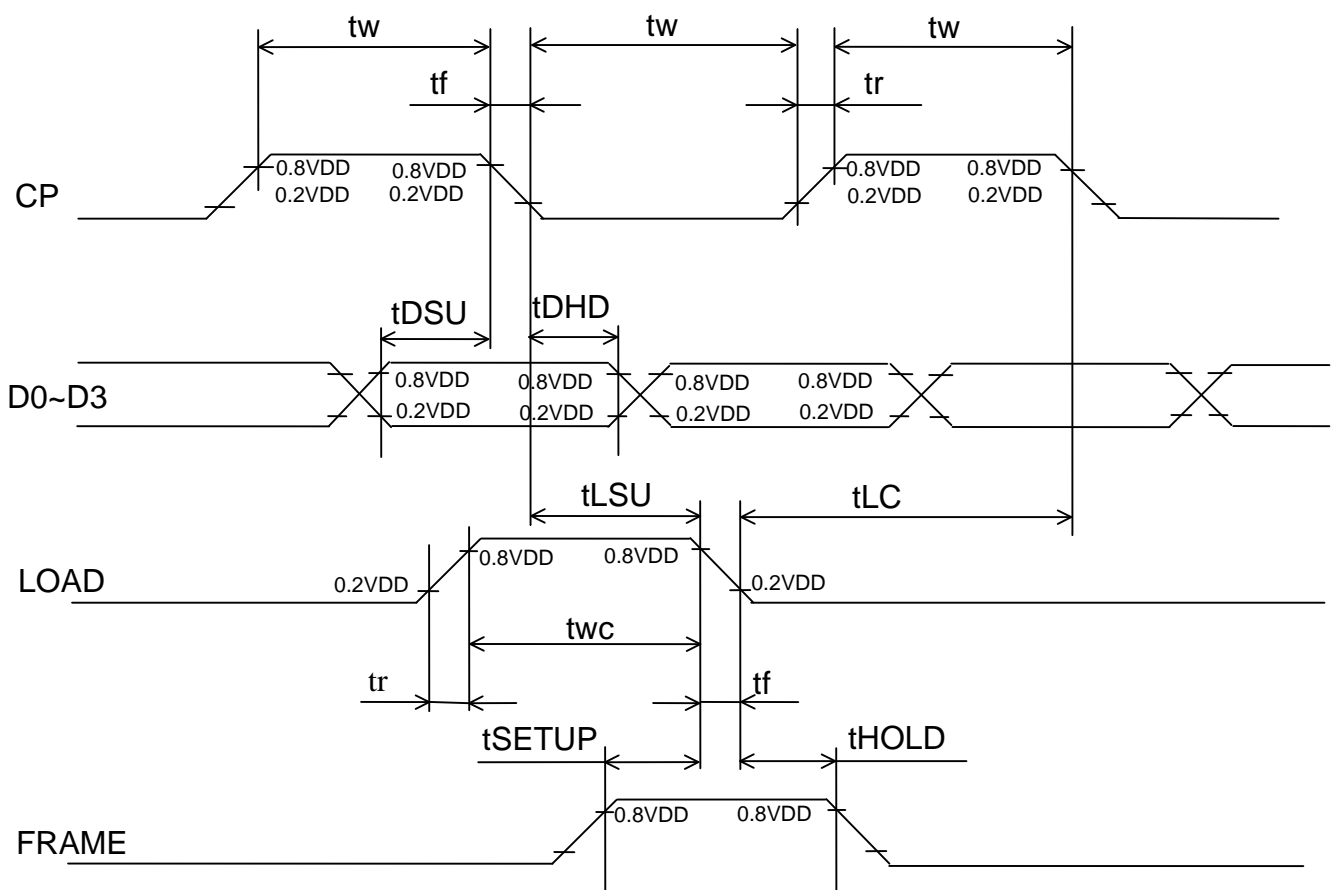

8.3 TIMING OF POWER SUPPLY AND INTERFACE SIGNAL

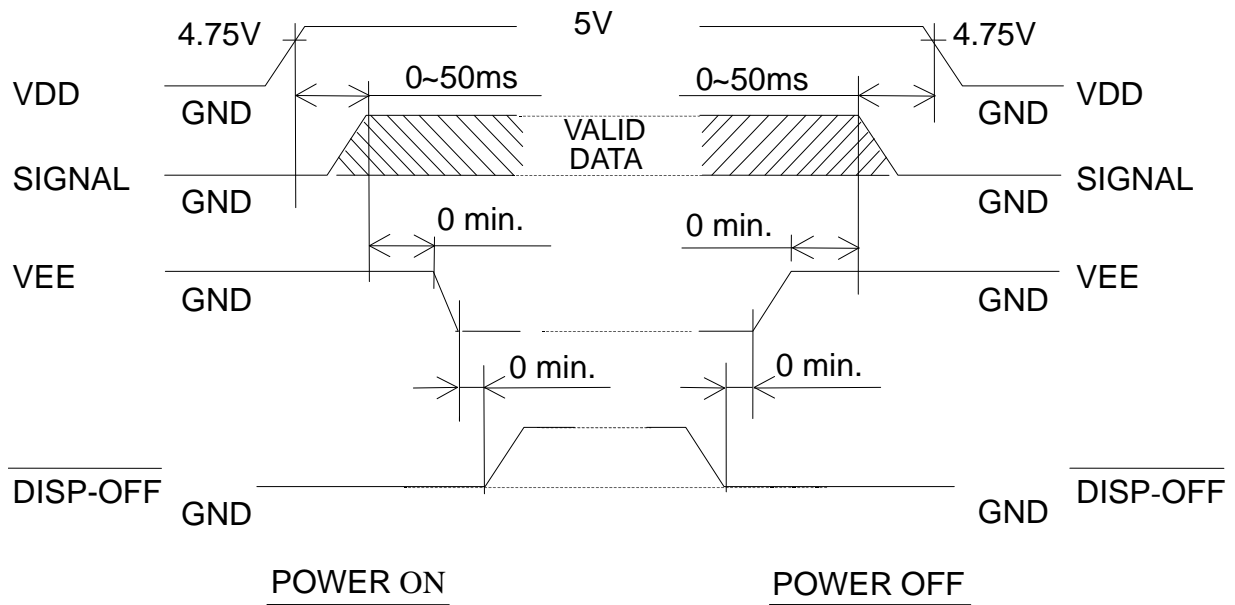

THE MISSING PIXELS MAY OCCUR WHEN THE LCM IS SRIVEN EXCEPT ABOVE POWER INTERFACE TIMING SEQUENCE.

8.4 POWER SUPPLY FOR LCM

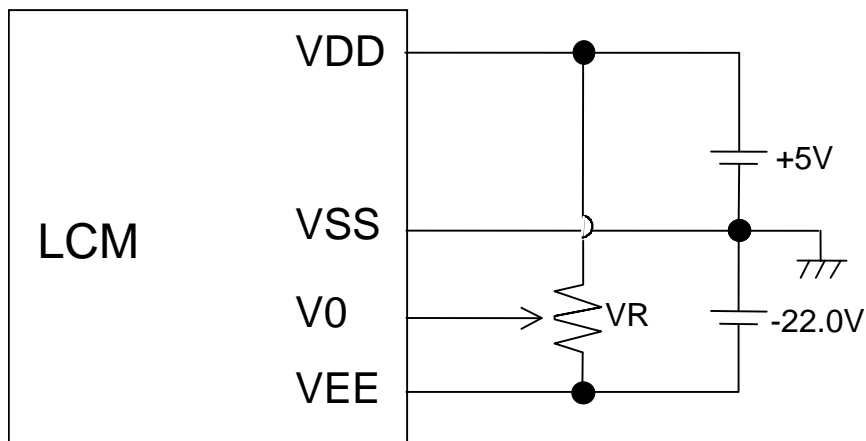

NOTE (1) VR : 10kΩ

NOTE (2) WE RECOMMEND TO ADD FUSE (1A) TO VDD LINE.

9.DIMENSIONAL OUTLINE
9.1DIMENSIONAL OUTLINE

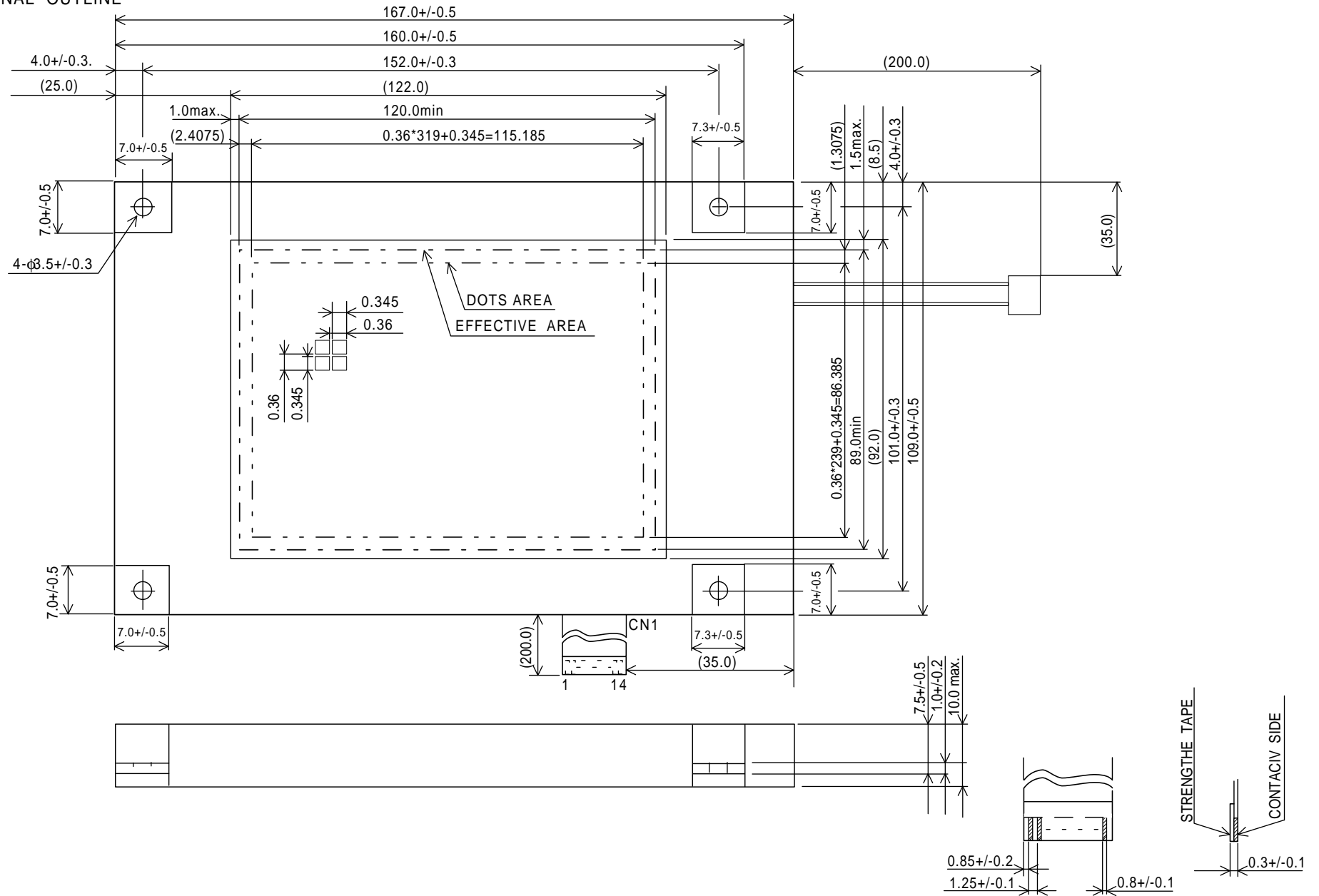

9.2 DISPLAY PATTERN

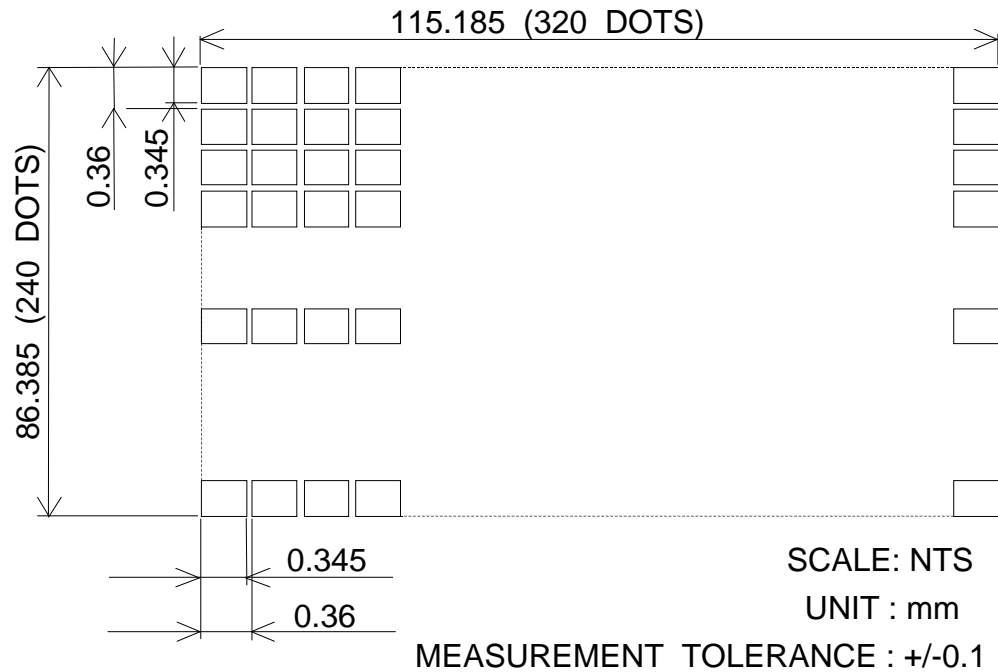

9.3 INTERFACE PIN CONNECTION

FPC: PITCH 1.0mm 16 PINS

INTERFACE		PIN No.	SIGNAL	LEVEL	FUNCTION
LCM	I/F1	1	D0	H/L	DISPLAY DATA
		2	D1		
		3	D2		
		4	D3		
		5	DISP-OFF	H/L	H: ON / L: OFF
		6	FRAME	H	FIRST LINE MARKER
		7	N.C	-	-
		8	LOAD	H→L	DATA LATCH
		9	CP	H→L	DATA SHIFT
		10	VDD	-	POWER SUPPLY FOR LOGIC
		11	VSS	-	GND
		12	VEE	-	POWER SUPPLY FOR LC
		13	V0	-	OPERATING VOLTAGE LC DRIVING
		14	VSS	-	GND

INTERFACE		PIN No.	SIGNAL	LEVEL	FUNCTION
CFL	CFL I/F	1	VCFL	-	POWER SUPPLY FOR CFL
		2	N.C	-	-
		3	N.C	-	-
		4	VCFL	-	CFL GND

CFL I/F: J. A. E. / IL - G - 4S - S3C2

10. APPEARANCE STANDARD

10.1 APPEARANCE INSPECTION CONDITIONS (IN THE EFFECTIVE VIEWING AREA) VISUAL INSPECTION SHOULD BE UNDER THE FOLLOWING CONDITION.

- (1) IN THE DARK ROOM.
- (2) WITH CFL PANEL LIGHTED WITH PRESCRIBED INVERTER CIRCUIT.
- (3) WITH EYES 25cm DISTANCE FROM LCM.
- (4) VIEWING ANGLE WITHIN 45 DEGREES FROM THE VERTICAL LINE TO THE CENTER LCD.

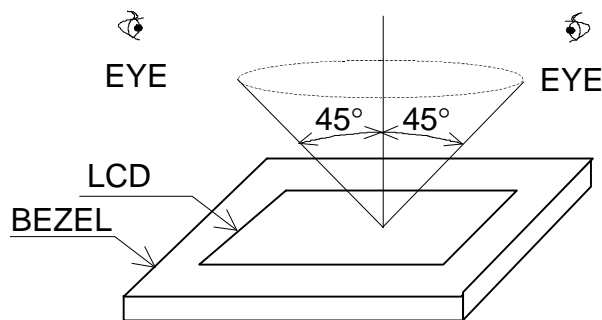

10.2 DEFINITION OF EACH ZONE

A ZONE : WITHIN THE VIEWING AREA SPECIFIED AT PAGE 9-1/2 OF THIS DOCUMENT.

B ZONE : AREA BETWEEN THE EDGE LINE OF LCD GLASS AND THE VIEWING AREALINE SPECIFIED AT PAGE 9-1/2 OF THIS DOCUMENT.

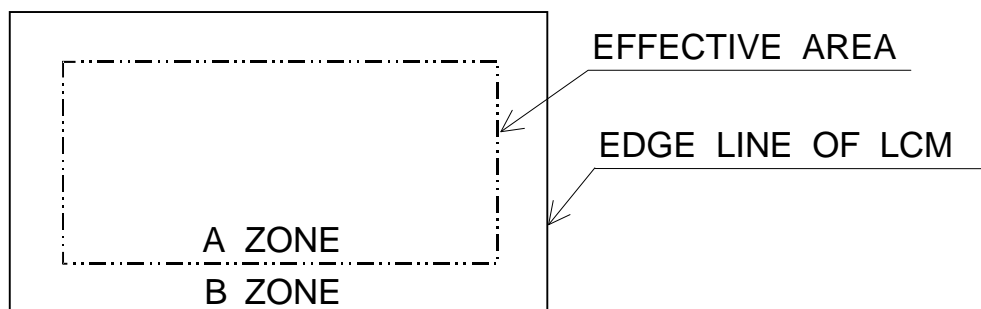

10.3 APPEARENCE SPECIFICATION

*) IF THE PROBLEM OCCURESS ABOUT THIS ITEM, THE RESPONSIBLE PERSON OF BOTH PARTY (CUSTOMER AND HITACHI) WILL DISCUSS MORE DETAIL.

No.	ITEM	CRITERIA				A	B	
L C D	SCRATCHES	DISTINGUISHED ONE IS NOT ACCEPTABLE (TO BE JUDGED BY HITACHI LIMIT SAMPLE)				*	-	
	DENT	SAME AS ABOVE				*	-	
	WRINKLES IN POLARIZER	SAME AS ABOVE				*	-	
	BUBBLES	AVERAGE DIAMETER D(mm)		MAXIMUM NUMBER ACCEPTABLE		O	-	
		D<=0.2		IGNORE				
		0.2<D<=0.3		12				
		0.3<D<=0.5		3				
		0.5<D		NONE				
	STAINS, FOREIGN MATERIALS DARK SPOT	FILAMENTOUS						
		LENGTH L(mm)	WIDTH W(mm)	MAXIMUM NUMBER ACCEPTABLE			O	-
		L<=2.0	W<=0.03	IGNORE				
		L<=3.0	0.03<W<=0.05	6				
		-	0.05<W	NONE				
		ROUND						
		AVERAGE DIA- METER D(mm)	MAXIMUM NUMBER ACCEPTABLE	MINIMUM SPACE		O	-	
		D<0.2	IGNORE	-				
		0.2 <=D<0.33	8	10mm				
		0.33<=D	NONE	-				
	THE WHOLE NUMBER	FILAMENTOUS + ROUND = 10						
	THOSE WIPED OUT EASILY ARE ACCEPTABLE					O	O	
	COLOR TONE	TO BE JUDGE BY HITACHI LIMIT SAMPLE				O	-	
	COLOR UNIFORMITY	SAME AS ABOVE				O	-	
	PINHOLE	AVERAGE DIAMETER D(mm)		MAXIMUM NUMBER ACCEPTABLE		O	-	
		D<=0.15		IGNORE				
		0.15<D<=0.3		10				
C<=0.015		IGNORE						
CONTRAST IRREGULARITY (SPOT)	AVERAGE DIAMETER D(mm)	CONTRAST	MAXIMUM NUMBER ACCEPTABLE	MINIMUM SPACE	O	-		
	D<=0.25	TO BE JUDGED BY HITACHI	IGNORE	-				
	0.25<D<=0.35		10	20mm				
	0.35<D<=0.5		4	20mm				
	0.5 <D		NONE	-				

No.	ITEM	CRITERIA				A	B
L C D	CONTRAST IRREGULARITY (LINE) (FILAMENTOUS)	WIDTH D(mm)	LENGTH L(mm)	MAXIMUM NUMBER ACCEPTABLE	MINIMUM SPACE	O	-
		$W \leq 0.25$	$L \leq 1.2$	2	20mm		
		$W \leq 0.2$	$L \leq 1.5$	3	20mm		
		$W \leq 0.15$	$L \leq 2.0$	3	20mm		
		$W \leq 0.1$	$L \leq 3.0$	4	20mm		
	THE WHOLE NUMBER	6					
	RUBBING SCRATCH	TO BE JUDGED BY HITACHI STANDARD				O	-

No.	ITEM	CRITERIA		
C F L B / L	DARK SPOTS, WHITE SPOTS FOREIGN MATERIALS (SPOT)	$D \leq 0.4$		IGNORE
		$D > 0.4$		NONE
	FOREIGN MATERIALS (LINE)	$W \leq 0.2$	$L < 2.5$	≤ 1
		$W \leq 0.2$	$L > 2.5$	NONE
		$W > 0.2$		NONE
	SCRATCHES	$W \leq 0.1$		IGNORE
		$0.1 < W \leq 0.2$	$L \leq 11.0$	≤ 1
		$0.1 < W \leq 0.2$	$L > 11.0$	NONE
$W < 0.2$		NONE		

NOTE (1)

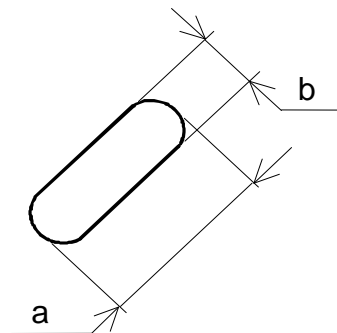
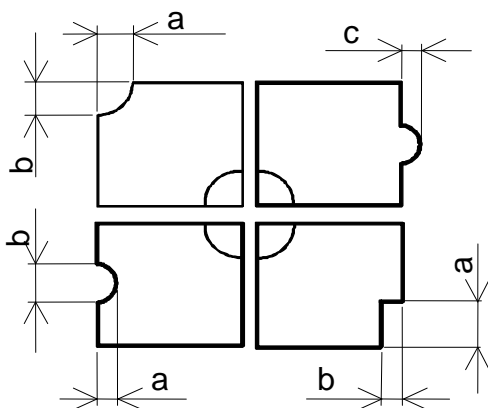

$$\frac{a+b}{2} = D \dots \text{AVERAGE DIAMETER}$$

$$C \dots \text{SALIENT}$$

(1) DEFINITION OF LENGTH L AND WIDTH W

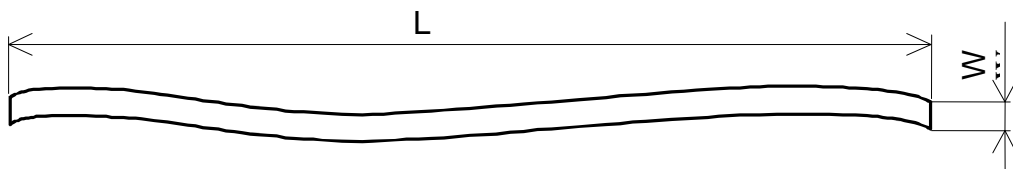

11. PRECAUTION IN DESIGN

11.1 LC DRIVING VOLTAGE (VEE) AND VIEWING ANGLE RANGE.

SETTING VEE OUT OF THE RECOMMENDED CONDITION WILL BE A CAUSE FOR A CHANGE OF VIEWING ANGLE RANGE.

11.2 CAUTION AGAINST STATIC CHARGE

AS THIS MODULE IS PROVIDED WITH C-MOS LSI, THE CARE TO TAKE SUCH A PRECAUTION AS TO GROUNDING THE OPERATOR'S BODY IS REQUIRED WHEN HANDLING IT.

11.3 POWER ON SEQUENCE

INPUT SIGNALS SHOULD NOT BE APPLIED TO LCD MODULE BEFORE POWER SUPPLY VOLTAGE IS APPLIED AND REACHES TO SPECIFIED VOLTAGE (5V+/-0.5%).

IF ABOVE SEQUENCE IS NOT KEPT, C-MOS LSIS OF LCD MODULES MAY BE DAMAGED DUE TO LATCH UP PROBLEM.

11.4 PACKAGING

- (1) NO. LEAVING PRODUCTS IS PREFERABLE IN THE PLACE OF HIGH HUMIDITY FOR A LONG PERIOD OF TIME. FOR THEIR STORAGE IN THE PLACE WHERE TEMPERATURE IS 35°C OR HIGHER, SPECIAL CARE TO PREVENT THEM FROM HIGH HUMIDITY IS REQUIRED. A COMBINATION OF HIGH TEMPERATURE AND HIGH HUMIDITY MAY CAUSE THEM POLARIZATION DEGRADATION AS WELL AS BUBBLE GENERATION AND POLARIZER PEEL-OFF. PLEASE KEEP THE TEMPERATURE AND HUMIDITY WITHIN THE SPECIFIED RANGE FOR USE AND STORAGE.
- (2) SINCE UPPER/BOTTOM POLARIZERS TEND TO BE EASILY DAMAGED, THEY SHOULD BE HANDLED FULL WITH CARE SO AS NOT TO GET THEM TOUCHED, PUSHED OR RUBBED.
- (3) AS THE ADHESIVES USED FOR ADHERING UPPER/BOTTOM POLERIZERS ARE MADE OF ORGANIC SUBSTANCES WHICH WILL BE DETERIORATED BY A CHEMICAL REACTION WITH SUCH CHEMICALS AS ACETONE, TULUENE, ETHANOLE AND ISOPROPYLALCOHOL. THE FOLLOWING SOLVENTS ARE RECOMMENDED FOR USE:
NORMAL HEXANE
PLEASE CONTACT US WHEN IT IS NECESSARY FOR YOU TO USE CHEMICALS.
- (4) LIGHTLY WIPE TO CLEAN THE DIRTY SURFACE WITH ABSORBENT COTTON WASTE OR OTHER SOFT MATERIAL LIKE CHAMOIS , SOAKED IN THE CHAMICALS RECOMMENDED WITHOUT SCRUBBING IT HARDLY. TO PREVENT THE DISPLAY SURFACE FROM DAMAGE AND KEEP THE APPEARANCE IN GOOD STATE, IT IS SUFFICIENT, IN GENERAL, TO WIPE IT WITH ABSORBENT COTTON.

- (5) IMMEDIATELY WIPE OFF SALIVA OR WATER DROP ATTACHED ON THE DISPLAY AREA BECAUSE ITS LONG PERIOD ADHERANCE MAY CAUSE DEFORMATION OR FADED COLOR ON THE SPOT.
- (6) FOGY DEW DEPOSITED ON THE SURFACE AND CONTACT TERMINALS DUE TO COLDNESS WILL BE CAUSE FOR POLARIZER DAMAGE, STAIN AND DIRT ON PRODUCT. WHEN NECESSARY TO TAKE OUT THE PRODUCTS FORM SOME PLACE AT LOW TEMPERATURE FOR TEST, ETC. IT IS REQUIRED FOR THEM TO BE WARMED UP IN A CONTAINER ONCE AT THE TEMPERATURE HIGHER THAN THAT OF ROOM.
- (7) TOUCHING THE DISPLAY AREA AND CONTANT TERMINALS WITH BARE HANDS AND CONTAMINATING THEM ARE PROHIBITED, BECAUSE THE STAIN ON THE DISPLAY AREA AND POOR INSULATION BETWEEN TERMINALS ARE OFTEN CAUSED BY BEING TOUCHED BY BARE HANDS. (THERE ARE SOME COSMETICS DETRIMENTAL TO POLARIZERS.)
- (8) IN GENERAL THE QUALITY OF GLASS IS FRAGILE SO THAT IT TENDS TO BE CRACKED OR CHIPPED IN HANDLING, SPECIALLY ON ITS PERIPHERY. BECAUSE BE CAREFUL NOT TO GIVE IT SHARP SHOCK CAUSED BY DROPPING DOWN, ETC.

11.5 CAUTION FOR HANDING

THIS LCM (SP14Q002) HAS NO METAL FRAME AND FRONT BEZEL TO PROTECT TCP(TAPE CARRIER PACKAGE). TCP DRIVER IS VERY WEAK AGAINST ANY MECHANICAL STRESS. IF SUCH STRESS APPLIED, OPEN CIRCUIT OF TCP DRIVER MAY OCCUR. AND IT CAN'T BE REPAIRED. PLEASE NOTICE THAT THIS LCM SHOULD BE HANDLED WITH ENOUGH CARE AS FOLLOWS.

- (1) WHEN HANDLING, HOLD LCD GLASS TO AVOID DAMAGING TCP. DO NOT HOLD PCB(PRONTED CIRCUIT BOARD).
- (2) AFTER INCOMING INSPECTION OF THIS LCM, WHEN TAKING OFF INTERFACE CABLE, BE CAREFUL NOT TO MAKE ANY MECHANICAL STRESS TO TCP, SUCH AS BENDING AND TWISTING.

11.6 CAUTION FOR OPERATION

- (1) IT IS AN INDISPENSABLE CONDITION TO DRIVE LCD'S WITHIN THE SPECIFIED VOLTAGE LIMIT SINCE THE HIGHER VOLTAGE THAN THE LIMIT CAUSES THE SHORTER LCD LIFE . AN ELECTROCHEMICAL REACTION DUE TO DIRECT CURRENT CAUSES LCD'S UNDESIRABLE DETERIORATION, SO THAT THE USE OF DIRECT CURRENT DRIVER SHOULD BE AVOIDED.
- (2) RESPONSE TIME WILL BE EXTREMELY DELAYED AT LOWER TEMPERATURE THAN THE OPERATING TEMPERATURE RANGE AND ON THE OTHER HAND AT HIGHER TEMPERATURE LCD'S SHOW DARK BULL COLOR IN THEM . HOWEVER THOSE PHENOMENA DO NOT MEAN MALFUNCTION OR OUT OF ORDER WITH LCD'S WHICH WILL COME BACK IN THE SPECIFIED OPERATING TEMPERATURE RANGE.
- (3) IF THE DISPLAY AREA IS PUSHED HARD DURING OPERATION , SOME FONT WILL BE ABNORMALLY DISPLAYED BUT IT RESUMES NORMAL CONDITION AFTER TURNING OFF ONCE.
- (4) A SLIGHT DEW DEPOSITING ON TERMINALS IS A CAUSE FOR ELECTROCHEMICAL REACTION RESULTING IN TERMINAL OPEN CIRCUIT. USAGE UNDER THE RELATIVE CONDITION OF 40°C 50%RH OR LESS IS REQUIRED.

11.7 STORAGE

IN CASE OF STORING FOR A LONG PERIOD OF TIME (FOR INSTANCE, FOR YEARS) FOR THE PURPOSE OF REPLACEMENT USE , THE FOLLOWING WAYS ARE RECOMMENDED.

- (1) STORAGE IN A PLOYETHYLENE BAG WITH THE OPENING SEALED SO AS NOT TO ENTER FRESH AIR OUTSIDE IN IT , AND WITH NO DESICCANT.
- (2) PLACING IN A DARK PLACE WHERE NEITHER EXPOSURE TO DIRECT SUNLIGHT NOR LIGHT IS, KEEPING TEMPERATURE IN THE RANGE FROM 0 DEGREE C TO 35 DEGREE.
- (3) STORING WITH NO TOUCH ON POLARIZER SURFACE BY ANYTHING ELSE. (IT IS RECOMMENDED TO STORE THEM AS THEY HAVE BEEN CONTAINED IN THE INNER CONTAINER AT THE TIME OF DELIVERY FROM US.)

11.8 SAFETY

- (1) IT IS RECOMMENDABLE TO CRASH DAMAGED OR UNNECESSARY LCDS INTO PIECES AND WASH OFF LIQUID CRYSTAL BY EITHER OF SOLVENTS SUCH AS ACETONE AND ETHANOL, WHICH SHOUD BE BURNED UP LATER.
- (2) WHEN ANY LIQUID LEAKED OUT OF A DAMAGED GLASS CELL COMES IN CONTACT WITH YOUR HANDS, PLEASE WASH IT OFF WELL WITH SOAP AND WATER.

12. DESIGNATION OF LOT MARK

LOT MARK

LOT MARK IS CONSISTED OF 4 DIGIT NUMBER.

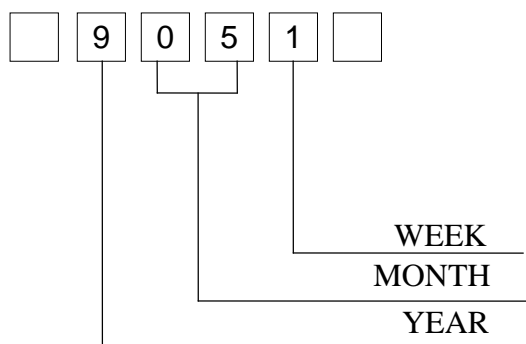

YEAR	FIGURE IN LOT MARK
1999	9
2000	0
2001	1
2002	2
2003	3

NOTE 1. SOME PRODUCTS HAVE ALPHABET AT THE END OR THE FIRST.

MONTH	FIGURE IN LOT MARK	MONTH	FIGURE IN LOT MARK
JAN.	01	JULY.	07
FEB.	02	AUG.	08
MAR.	03	SEPT.	09
APR.	04	OCT.	10
MAY.	05	NOV.	11
JUNE.	06	DEC.	12

WEEK (DAY IN CALENDAR)	FIGURE IN LOT MARK
01~07	1
08~14	2
15~21	3
22~28	4
29~31	5

LOCATION OF LOT MARK : ON THE BACK SIDE OF LCM

9 0 5 1 T

T : MADE IN TAIWAN.

13. PRECAUTION FOR USE

- (1) A LIMIT SAMPLE SHOULD BE PROVIDED BY THE BOTH PARTIES ON AN OCCASION WHEN THE BOTH PARTIES AGREED ITS NECESSITY. JUDGEMENT BY A LIMIT SAMPLE SHALL TAKE EFFECT AFTER THE LIMIT SAMPLE HAS BEEN ESTABLISHED AND CONFIRMED BY THE BOTH PARTIES.
- (2) ON THE FOLLOWING OCCASIONS, THE HANDLING OF THE PROBLEM SHOULD BE DECIDED THROUGH DISCUSSION AND AGREEMENT BETWEEN RESPONSIBLE PERSONS OF THE BOTH PARTIES.

- (1) WHEN A QUESTION IS ARISEN IN THE SPECIFICATIONS.
- (2) WHEN A NEW PROBLEM IS ARISEN WHICH IS NOT SPECIFIED IN THIS SPECIFICATIONS.
- (3) WHEN AN INSPECTION SPECIFICATIONS CHANGE OR OPERATING CONDITION CHANGE IN CUSTOMER IS REPORTED TO HITACHI, AND SOME PROBLEM IS ARISEN IN THIS SPECIFICATION DUE TO THE CHANGE.
- (4) WHEN A NEW PROBLEM IS ARISEN AT THE CUSTOMER'S OPERATING SET FOR SAMPLE EVALUATION IN THE CUSTOMER SITE.

THE PRECAUTION THAT SHOULD BE OBSERVED WHEN HANDLING LCM HAVE BEEN EXPLAINED ABOVE. IF ANY POINTS ARE UNCLEAR OR IF YOU HAVE ANY REQUESTS , PLEASE CONTACT HITACHI.

KAOHSIUNG HITACHI ELECTRONICS CO.,LTD.	DATE	Apr.26.'99	Sh. No.	7B64PS 2713-SP14Q002-T-1	PAGE	13-1/1
---	------	------------	------------	--------------------------	------	--------