

ZXSC400EV2 - circuit diagram and bill of materials

Circuit diagram

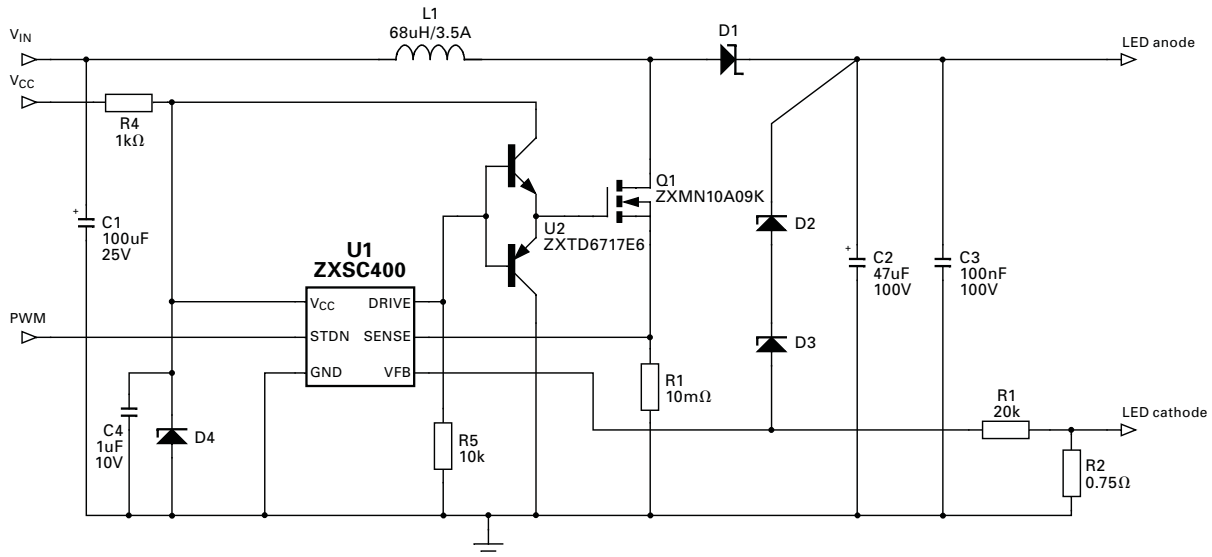

Bill of materials

Qty.	Part ref.	Value	Description	Suggested source
6	V _{IN} , V _{CC} , GND, PWM, LED anode, LED cathode	N/A	Test loop, Hughes 100-108	Rapid 17-1835
1	U1		ZXSC400E6	Zetex
1	U2		ZXTD6717E6	Zetex
1	Q1		ZXMN10A09K	Zetex
1	D1	100V/1A	10BQ100 Schottky diode	International Rectifier
2	D2, D3	47V	BZX84C47 zener diode	Philips Semiconductors
1	D4	7V5	BZX84C7V5 zener diode	Philips Semiconductors
1	R1	10mΩ	1206 5% tol.	
1	R2	0.75Ω	1206 5% tol.	Mouser
1	R3	20kΩ	0805 5% tol.	
1	R4	1kΩ	0805 5% tol.	
1	R5	10kΩ	0806 5% tol.	
1	L1	68µH/3.5A	DO5022P-683 inductor	Coilcraft
1	C1	100µF/25V/E	EEVFK1E101P capacitor SMT	Panasonic
1	C2	47µF/100V/H13	EEVFK2A470Q capacitor SMT	Panasonic
1	C3	100nF/100V	100nF/100V/1206/Y5V, ceramic cap	
1	C4	1µF/10V	1uF/10V/0805/X7R	Farnell 940-6301