

HIGH FREQUENCY MAGNETICS

T1/E1 Surface Mount Transformers

TM00138

- Operates at the T1 rate of 1.544 Mbits/s and at the E1 rate of 2.048 Mbits/s
- Designed for transmit and receive line interface applications
- Low capacitance design with specific interwinding insulation (2779L)
- 1500 Volt isolation
- Operating temperature range: -40° C to +85° C
- Meets IEC 695, 2-2 flammability requirements
- PWB Process Capability: standard printed wiring board assembly techniques, total-immersion cleaning
- Reliability testing: Shock, vibration, temperature cycling, temperature - humidity - bias

ELECTRICAL SPECIFICATIONS AT 25° C

| Part Number | Nominal Turns Ratio ±2% | Inductance ² mH min | DCR Ω max | | Leakage Inductance ³ μH max | Interwinding Capacitance ¹ pF | Minimum Interwinding Breakdown Voltage Vrms |
|-------------|----------------------------|-----------------------------------|--------------|-------|---|---|--|
| | (4-1):(5-8) ¹ | | (4-1) | (4-1) | | | |
| 2779G | 1 : 1.14 CT | 1.80 | 1.2 | 1.4 | 1.3 | 20 typ | 1500 |
| 2779L | 1 : 1.14 CT | 1.25 | 0.9 | 0.5 | 1.8 | 10 max | 1500 |

- connect 6 to 7
- measured at 10 kHz, 0.1 Vac
- measured at 100 kHz

SCHEMATIC

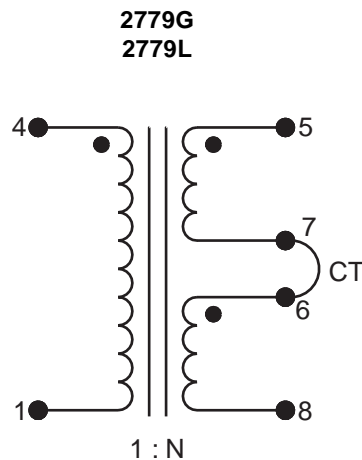

MECHANICAL

2779G
2779L

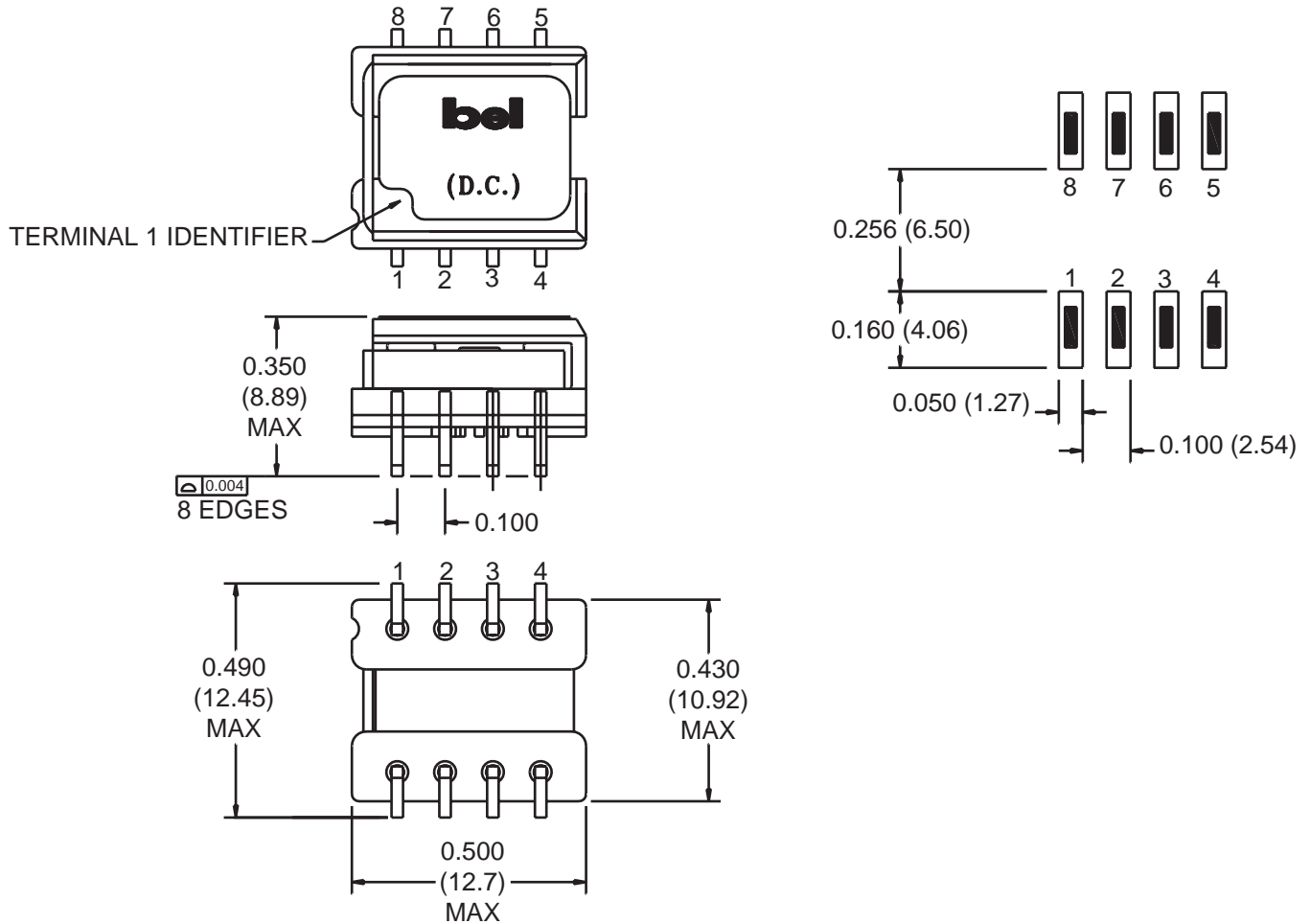

Unless otherwise specified, dimensions are nominal and in inches (millimeters).

CORPORATE

Bel Fuse Inc.
198 Van Vorst Street
Jersey City, NJ 07302
Tel 201-432-0463
Fax 201-432-9542
www.belfuse.com

FAR EAST

Bel Fuse Ltd.
8F / 8 Luk Hop Street
San Po Kong
Kowloon, Hong Kong
Tel 852-2328-5515
Fax 852-2352-3706
www.belfuse.com

EUROPE

Bel Fuse Europe Ltd.
Preston Technology Management Centre
Marsh Lane, Suite G7, Preston
Lancashire, PR1 8UD, U.K.
Tel 44-1772-556601
Fax 44-1772-888366
www.belfuse.com