

PROPRIETARY DATA:

This document and information contained may not be reproduced, used or disclosed without prior written permission of WESTCOR a division of VICOR Corporation.

REVISION HISTORY				
ECO	REV	DESCRIPTION	DATE	APPROVED
431	A	PRODUCTION RELEASE	03-21-96	RBD
567	B	DIM:2.79 IS:4.25+.25\-.0 AD TOL	07-19-96	RBD
605	C	DIM MAX DIA WAS 1.53	12-31-98	RBD
1023	D	CHG NOTES 2.1 & 3.2, TITLE CHG	06-13-00	RBD
1225	D1	ADD MATERIAL COMPLIANCE NOTE	06/19/03	LGK

NOTES: UNLESS OTHERWISE SPECIFIED

1. MATERIALS:

- 1.1 CORE: TOROID - 1.300 X .785 X .420 (IRON POWDER - LOW LOSS, $\mu = 60$)
MAGNETICS: 77071-A7
- 1.2 WIRE: U.L. RECOGNIZED 130°C (MIN) RATING
MAGNET WIRE-SOLDERABLE
- 1.3 OUTERWRAP UL RECONIZED (UL 510)
PERMASIL: #213, #286 OR 3M #69

2. SPECIFICATIONS:

- 2.1 L = 1.38mH +/- 25% @ 1mA, MIN/COIL (1KHZ, <1Vrms)
- 2.2 L = .45mH TYPICAL @ 6 ADC BIAS, 1 KHZ.
TEST FREQUENCY
- 2.3 DCR = .25 OHMS MAX

3. CONSTRUCTION:

3.1 WIND COIL EVENLY SPACED

3.2 WRAP INDUCTOR WITH TAPE, (PER NOTE 1.3).
MARK PART NUMBER AND REVISION IN (BLACK) APPROX.
WHERE SHOWN, USING A PERMANENT MARKING METHOD.

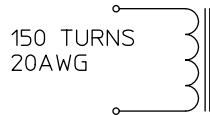
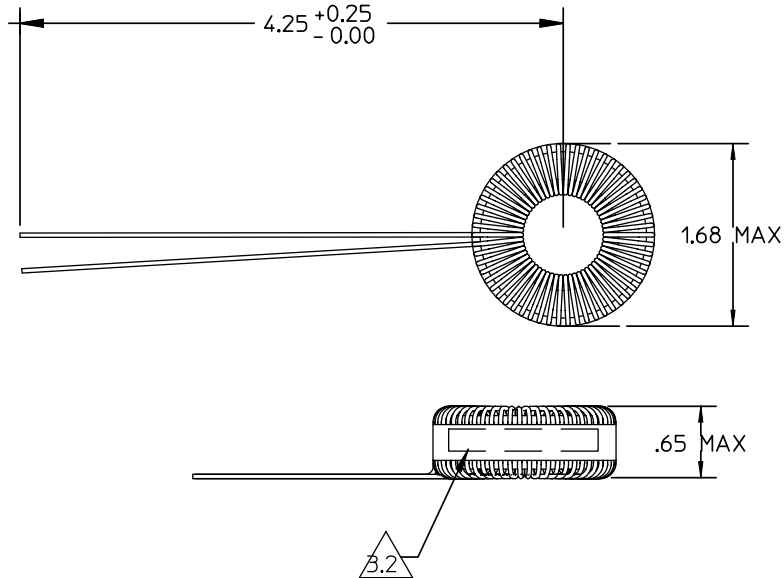

150 TURNS
20AWG

SCHEMATIC

NOTE: CERTIFICATION OF MATERIAL COMPLIANCE REQUIRED

		UNLESS OTHERWISE SPECIFIED DIMENSIONS ARE IN INCHES TOLERANCES ARE:	THIRD ANGLE PROJECTION		WESTCOR a division of VICOR Corp.					
		FRACTIONS .XX .XXX DECIMALS .01 .005 ANGLES 1/2°							INDUCTOR TOROID 1MH 4A 1.68 DIA X .65 WIDE	
		MATERIAL	SEE NOTES	APPROVALS	DATE	SIZE	CAGE CODE	DWG NO.		
---	SEE MIS	FINISH	SEE NOTES	DRAWN	S.KEITH	08/22/95	B	--	36-00036	D1
NEXT ASSY	USED ON			CHECKED	L.SANTOS	3/21/96				
APPLICATION		DO NOT SCALE DRAWING		APPROVED	R.B. DRABING	3/21/96	SCALE	NTS	FILENAME: 36-00036	SHEET 1 OF 1