

FEATURES:

- Four 512k x 8 SRAM die
- RAD-PAK® technology hardens against natural space radiation technology
- Total dose hardness:
 - > 100 krad (Si), depending upon space mission
- Excellent Single Event Effects:
 - SEL > 101MeV-cm²/mg
 - SEU threshold = 3 MeV-cm²/mg
 - SEU saturated cross section: 8E-9 cm²/bit
- Package: 68-pin quad flat package
- Completely static memory - no clock or timing strobe required
- Internal bypass capacitor
- High-speed silicon-gate CMOS technology
- 3.3 V ± 10% power supply
- Equal address and chip enable access times
- Three-state outputs
- All inputs and outputs are TTL compatible

DESCRIPTION:

Maxwell Technologies' 89LV1632 high-performance 16 Megabit Multi-Chip Module (MCM) Static Random Access Memory features a greater than 100 krad(Si) total dose tolerance, depending upon space mission. The four 4-Megabit SRAM die and bypass capacitors are incorporated into a high-reliable hermetic quad flat-pack ceramic package. With high-performance silicon-gate CMOS technology, the 89LV1632 reduces power consumption and eliminates the need for external clocks or timing strobes. It is equipped with output enable (\overline{OE}) and four byte chip enable ($\overline{CS1} - \overline{CS4}$) inputs to allow greater system flexibility. When \overline{OE} input is high, the output is forced to high impedance.

Maxwell Technologies' patented RAD-PAK® packaging technology incorporates radiation shielding in the microcircuit package. In a GEO orbit, RAD-PAK® packaging provides greater than 100 krad(Si) total radiation dose tolerance, dependent upon space mission. It eliminates the need for box shielding while providing the required radiation shielding for a lifetime in orbit or a space mission. This product is available in with screening up to Maxwell Technologies self-defined Class K.

16 Megabit (512K x 32-Bit) Low Voltage MCM SRAM 89LV1632

TABLE 1. PINOUT DESCRIPTION

PIN	SYMBOL	DESCRIPTION
34-28, 42-36, 62-64, 7, 8	A0-A18	Address Enable
65	\overline{WE}	Write Enable
66	\overline{OE}	Output Enable
3-6	$\overline{CS1} - \overline{CS4}$	Chip Enable
43-46, 48-51, 53-56, 58-61, 9-12, 14-17, 19-22, 24-27	I/O0-I/O31	Data Input/Output
2, 67, 68	NC	No Connection
1, 18, 35, 52	V _{CC}	+3.3V Power Supply
13, 23, 47, 57	V _{SS}	Ground

TABLE 2. 89LV1632 ABSOLUTE MAXIMUM RATINGS
(VOLTAGE REFERENCED TO V_{SS} = 0V)

PARAMETER	SYMBOL	MIN	MAX	UNITS
Power Supply Voltage Relative to V _{SS}	V _{CC}	-0.5	+7.0	V
Voltage Relative to V _{SS} for Any Pin Except V _{CC}	V _{IN} , V _{OUT}	-0.5	V _{CC} +0.5	V
Weight			42	Grams
Thermal Resistance	Φ _{JC}		3.6	°C/W
Power Dissipation	P _D	--	4.0	W
Operating Temperature	T _A	-55	+125	°C
Storage Temperature	T _S	-65	+150	°C

TABLE 3. 89LV1632 RECOMMENDED OPERATING CONDITIONS
(V_{CC} = 3.3±10%, T_A = -55 TO +125 °C, UNLESS OTHERWISE NOTED)

PARAMETER	SYMBOL	MIN	MAX	UNITS
Supply Voltage, (Operating Voltage Range)	V _{CC}	3.0	3.6	V
Input High Voltage	V _{IH}	2.2	V _{CC} + 0.5 ⁽¹⁾	V
Input Low Voltage	V _{IL}	-0.5 ⁽²⁾	0.8	V

- V_{IH} (max) = V_{CC} + 2V ac (pulse width ≤ 10ns) for I ≤ 80 mA.
- V_{IL} (min) = -2.0V ac; (pulse width ≤ 20 ns) for I ≤ 80 mA.

16 Megabit (512K x 32-Bit) Low Voltage MCM SRAM 89LV1632

TABLE 4. 89LV1632 DELTA LIMITS

PARAMETER	VARIATION
I_{CC}	$\pm 10\%$ of stated value in table 5
I_{SB}	$\pm 10\%$ of stated value in table 5
I_{SB1}	$\pm 10\%$ of stated value in table 5
I_{LI}	$\pm 10\%$ of stated value in table 5

TABLE 5. 89LV1632 DC ELECTRICAL CHARACTERISTICS

($V_{CC} = 3.3 \pm 10\%$, $T_A = -55$ TO $+125$ °C, UNLESS OTHERWISE NOTED)

PARAMETER	SYMBOL	TEST CONDITIONS	SUBGROUPS	MIN	TYP	MAX	UNITS
Input Leakage Current	I_{LI}	$V_{IN} = 0$ to V_{CC}	1, 2, 3	-8.0	--	+8.0	uA
Output Leakage Current	I_{LO}	$\overline{CS} = V_{IH}$, $V_{OUT} = V_{SS}$ to V_{CC}	1, 2, 3	-8.0	--	+8.0	uA
Average Operating Current Cycle Time: 35 ns	I_{CC}	Min. Cycle, 100% Duty, $\overline{CS} = V_{IL}$, $I_{OUT} = 0$ mA $V_{IN} = V_{IH}$ or V_{IL}	1, 2, 3	--	--	640	mA
Standby Power Supply Current	I_{SB}	$\overline{CS} = V_{IH}$, Min Cycle	1, 2, 3	--	--	240	mA
CMOS Standby Power Supply Current	I_{SB1}	$\overline{CS} \geq V_{CC} - 0.2V$, $f = 0$ MHz, $V_{IN} \geq V_{CC} - 0.2V$ or $V_{IN} < 0.2V$	1, 2, 3	--	--	40	mA
Output Low Voltage	V_{OL}	$I_{OL} = +8.0$ mA	1, 2, 3	--	--	0.4	V
Output High Voltage	V_{OH}	$I_{OH} = -4.0$ mA	1, 2, 3	2.4	--	--	V
Input Capacitance ¹ CS1 - CS4, OE, WE I/O0-7, I/O8-15, I/O16-23, I/O24-31 A0 - A18	C_{IN}	$V_{IN} = 0$ V	4, 5, 6			7 28 7 7 28	pF
Output Capacitance ¹	C_{OUT}	$V_{IO} = 0$ V	4, 5, 6			8	pF

1. Guaranteed by design.

TABLE 6. 89LV1632 AC OPERATING CONDITIONS AND CHARACTERISTICS

($V_{CC} = 3.3 \pm 10\%$, $T_A = -55$ TO $+125$ °C, UNLESS OTHERWISE NOTED)

PARAMETER	MIN	TYP	MAX	UNITS
Input Pulse Level	0.0	--	3.0	V
Output Timing Measurement Reference Level	--	--	1.5	V

16 Megabit (512K x 32-Bit) Low Voltage MCM SRAM 89LV1632

TABLE 6. 89LV1632 AC OPERATING CONDITIONS AND CHARACTERISTICS

($V_{CC} = 3.3 \pm 10\%$, $T_A = -55$ TO $+125$ °C, UNLESS OTHERWISE NOTED)

PARAMETER	MIN	TYP	MAX	UNITS
Input Rise/Fall Time	--	--	3.0	ns
Input Timing Measurement Reference Level	--	--	1.5	V

TABLE 7. 89LV1632 READ CYCLE

($V_{CC} = 3.3 \pm 10\%$, $T_A = -55$ TO $+125$ °C, UNLESS OTHERWISE NOTED)

PARAMETER	SYMBOL	SUBGROUPS	MIN	TYP	MAX	UNITS
Read Cycle Time -30	t_{RC}	9, 10, 11	30	--	--	ns
Address Access Time -30	t_{AA}	9, 10, 11	--	--	30	ns
Chip Select to Output -30	t_{CO}	9, 10, 11	--	--	30	ns
Output Enable to Output -30	t_{OE}	9, 10, 11	--	--	14	ns
Output Enable to Low-Z Output -30	t_{OLZ}	9, 10, 11	--	0	--	ns
Chip Enable to Low-Z Output -30	t_{LZ}	9, 10, 11	--	3	--	ns
Output Disable to High-Z Output -30	t_{OHZ}	9, 10, 11	--	8	--	ns
Chip Disable to High-Z Output -30	t_{HZ}	9, 10, 11	--	8	--	ns
Output Hold from Address Change -30	t_{OH}	9, 10, 11	3	--	--	ns
Chip Select to Power Up Time -30	T_{PU}	9, 10, 11	--	0	--	ns
Chip Select to Power Down Time -30	T_{PD}	9, 10, 11	--	20	--	ns

TABLE 8. 89LV1632 FUNCTIONAL DESCRIPTION

\overline{CS}	\overline{WE}	\overline{OE}	MODE	I/O PIN	SUPPLY CURRENT
H	X ¹	X ¹	Not Select	High-Z	I_{SB} , I_{SB1}
L	H	H	Output Disable	High-Z	I_{CC}
L	H	L	Read	D_{OUT}	I_{CC}
L	L	X ¹	Write	D_{IN}	I_{CC}

1. X = don't care.

16 Megabit (512K x 32-Bit) Low Voltage MCM SRAM 89LV1632

TABLE 9. 89LV1632 WRITE CYCLE
($V_{CC} = 3.3 \pm 10\%$, $T_A = -55$ TO $+125$ °C, UNLESS OTHERWISE NOTED)

PARAMETER	SYMBOL	SUBGROUPS	MIN	TYP	MAX	UNITS
Write Cycle Time -30	t_{WC}	9, 10, 11	30		--	ns
Chip Select to End of Write -30	t_{CW}	9, 10, 11	20		--	ns
Address Set-up Time -30	t_{AS}	9, 10, 11	0		--	ns
Address Valid to End of Write -30	t_{AW}	9, 10, 11	20		--	ns
Write Pulse Width (\overline{OE} High) -30	t_{WP}	9, 10, 11	20		--	ns
Write Pulse Width (\overline{OE} Low) -30	t_{WP1}	9, 10, 11	30		--	ns
Write Recovery Time -30	t_{WR}	9, 10, 11	0		--	ns
Write to Output High-Z -30	t_{WHZ}	9, 10, 11	--	9	--	ns
Data to Write Time Overlap -30	t_{DW}	9, 10, 11	14		--	ns
Data Hold from Write Time -30	t_{DH}	9, 10, 11	0		--	ns
End Write to Output Low-Z -30	t_{OW}	9, 10, 11	--	3	--	ns

16 Megabit (512K x 32-Bit) Low Voltage MCM SRAM 89LV1632

FIGURE 1. AC TEST LOADS

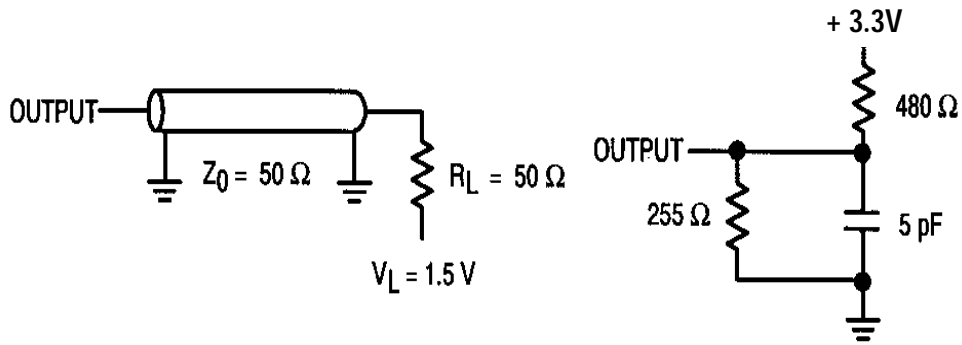

Figure 1A

Figure 1B

FIGURE 2. TIMING WAVEFORM OF READ CYCLE ⁽¹⁾ (ADDRESS CONTROLLED)

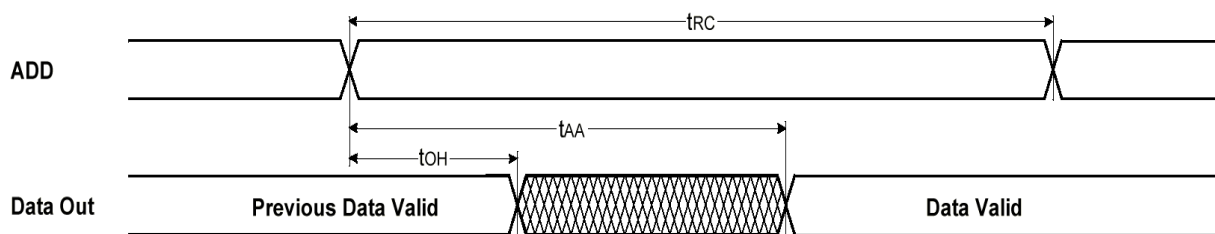
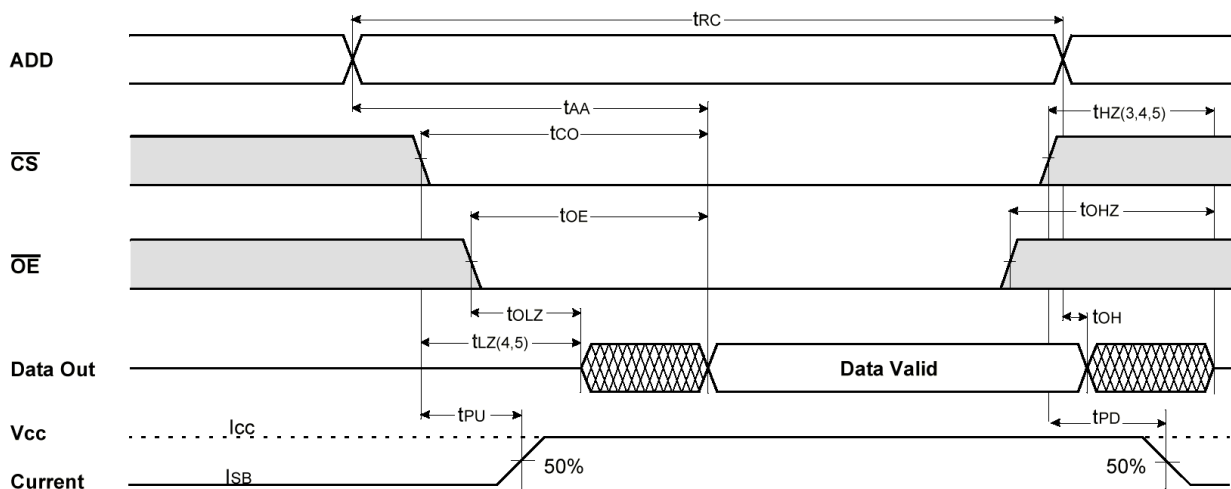

FIGURE 3. TIMING WAVEFORM OF READ CYCLE ⁽²⁾ ($\overline{WE} = V_{IH}$)



1. \overline{WE} is high for read cycle.
2. All read cycle timing is referenced from the last valid address to the first transition address.

16 Megabit (512K x 32-Bit) Low Voltage MCM SRAM 89LV1632

3. t_{HZ} and t_{OHZ} are defined as the time at which the outputs achieve the open circuit condition and are not referenced to V_{OH} or V_{OL} levels.
4. At any given temperature and voltage conditions, t_{HZ} (max) is less than t_{LZ} (min) both for a given device and from device to device.
5. Transition is measured $\pm 200\text{mV}$ from steady state voltage with Load(B). This parameter is sampled and not 100% tested.
6. Device is continuously selected with $\overline{CS} = V_{IL}$.
7. Address valid prior to coincident with \overline{CS} transition low.
8. For common I/O applications, minimization or elimination of bus contention conditions is necessary during read and write cycle.

FIGURE 4. TIMING WAVEFORM OF WRITE CYCLE ⁽¹⁾ (\overline{OE} CLOCK)

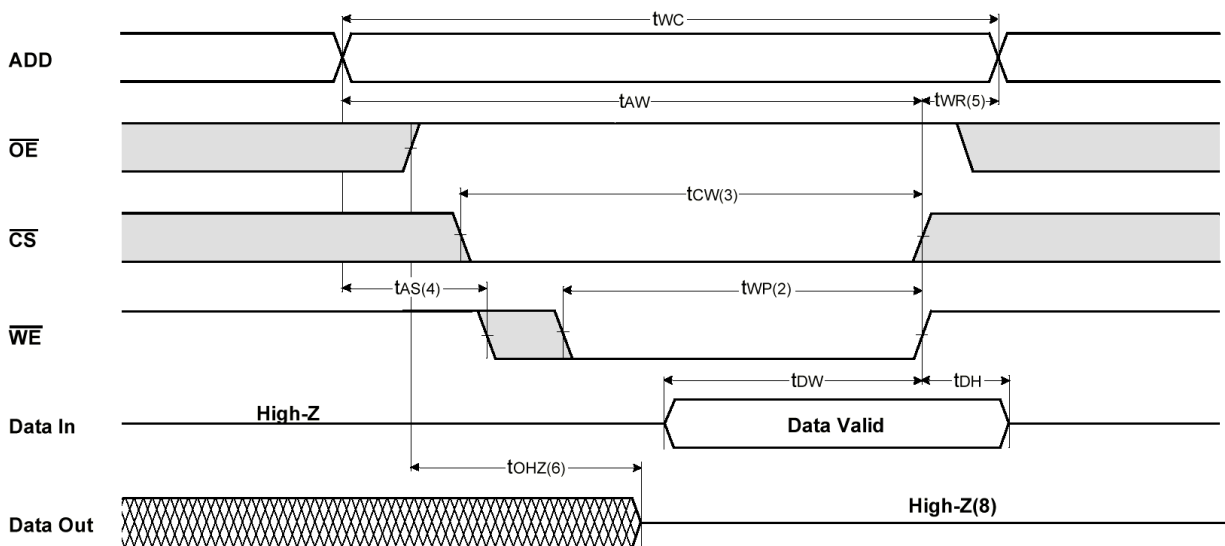

FIGURE 5. TIMING WAVEFORM OF WRITE CYCLE (2) (\overline{OE} LOW FIXED)

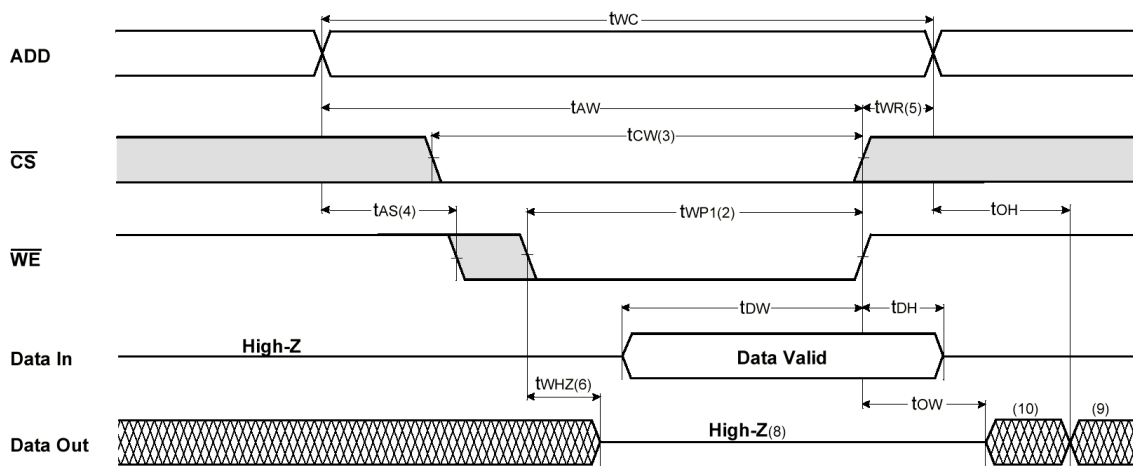
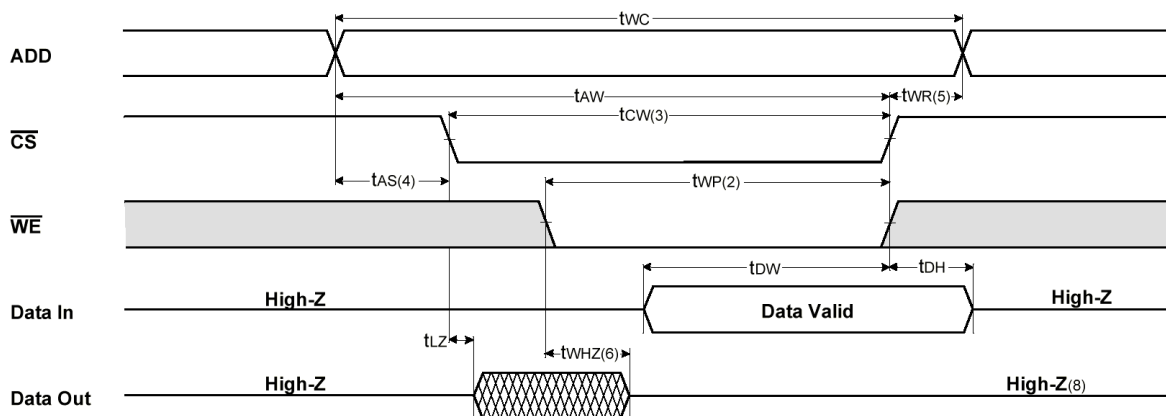

FIGURE 6. TIMING WAVEFORM OF WRITE CYCLE (3) (\overline{CS} CONTROLLED)



1. All write cycle timing is referenced from the last valid address to the first transition address.
2. A write occurs during the overlap of a low \overline{CS} and \overline{WE} . A write begins at the latest transition \overline{CS} going low and \overline{WE} going low. A write ends at the earliest transition \overline{CS} going high or \overline{WE} going high. t_{WP} is measured from the beginning of write to the end of write.
3. t_{CW} is measured from the later of \overline{CS} going low to end of write.
4. t_{AS} is measured from the address valid to the beginning of write.
5. t_{WR} is measured from the end of write to the address change. t_{WR} applied in case a write ends as \overline{CS} or \overline{WE} going high.
6. If \overline{OE} , \overline{CS} and \overline{WE} are in the Read Mode during this period, the I/O pins are in the output low-Z state. Inputs of opposite phase of the output must not be applied because bus contention can occur.
7. For common I/O applications, minimization of elimination of bus contention conditions is necessary during read and write cycle.
8. If \overline{CS} goes low simultaneously with \overline{WE} going or after \overline{WE} going low, the outputs remain high impedance state.
9. D_{OUT} is the read data of the new address.
10. When \overline{CS} is low, I/O pins are in the output state. The input signals in the opposite phase leading to the output should not be applied.

FIGURE 7. SRAM HEAVY ION CROSS SECTION

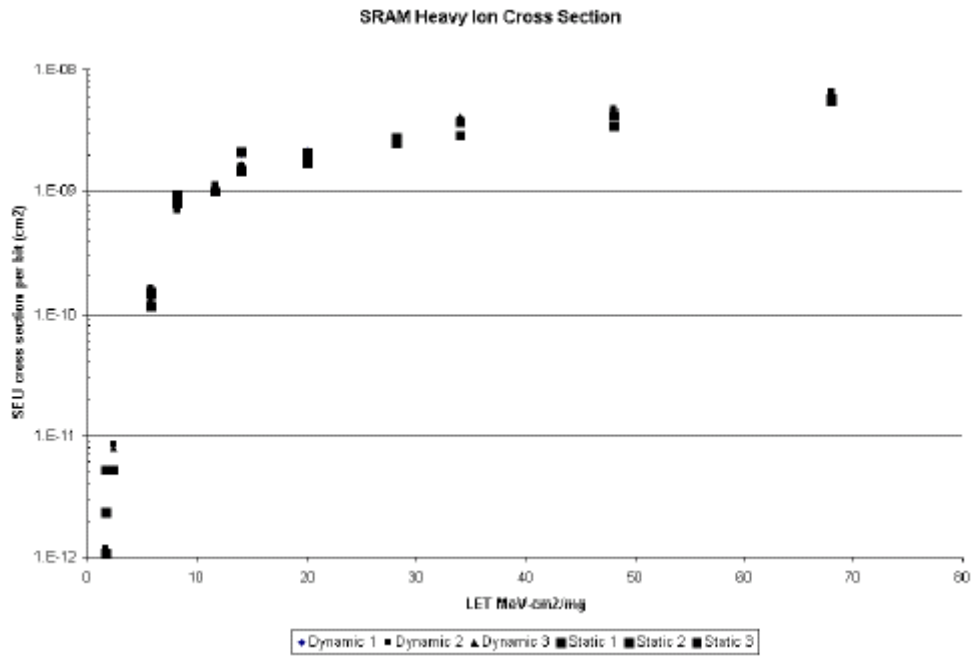
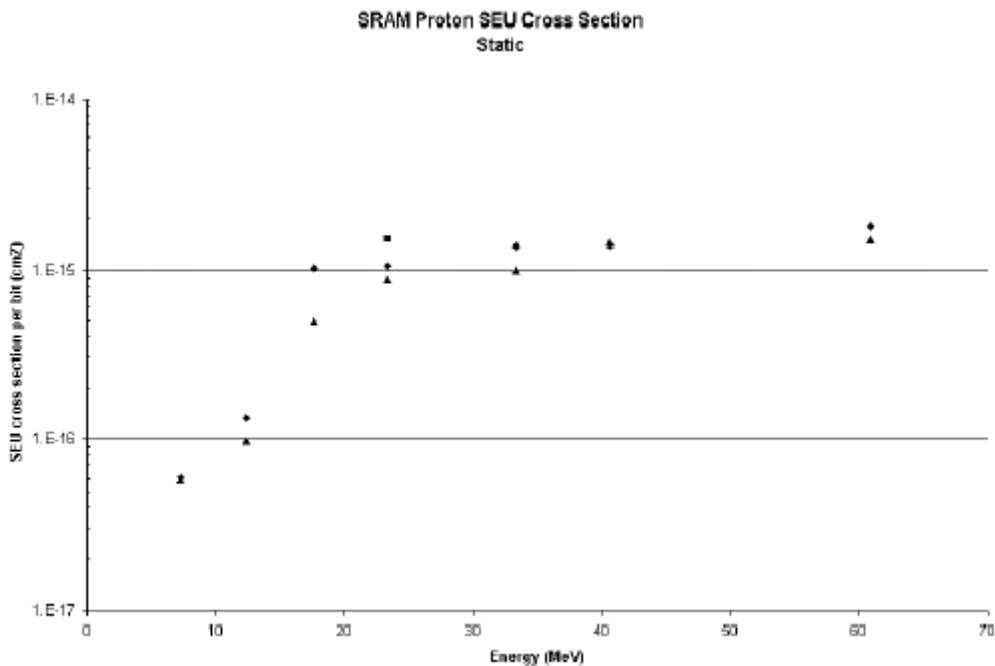
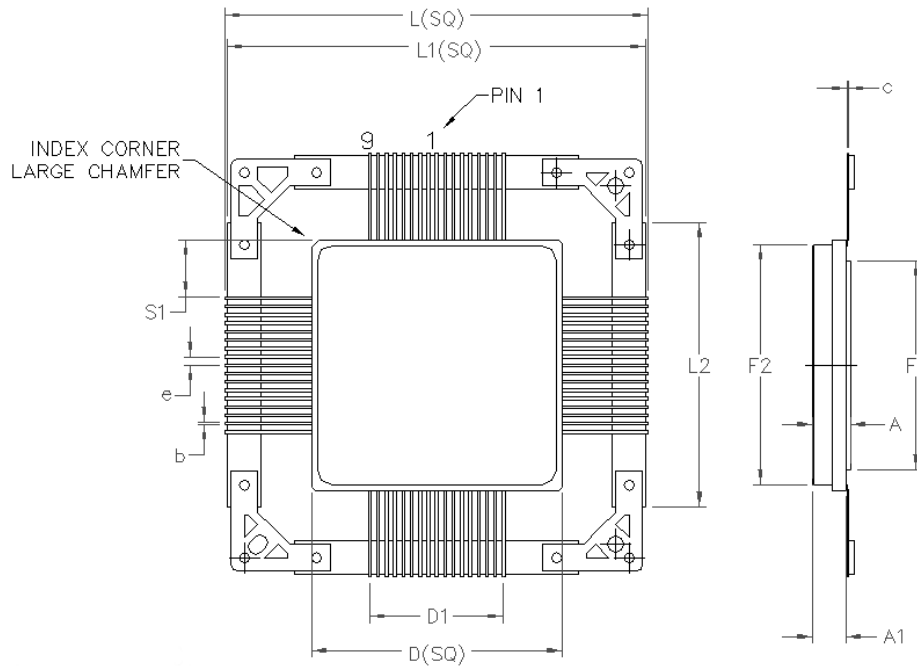

FIGURE 8. SRAM PROTON SEU CROSS SECTION STATIC



16 Megabit (512K x 32-Bit) Low Voltage MCM SRAM 89LV1632



68 PIN RAD-PAK® QUAD FLAT PACKAGE

SYMBOL	DIMENSION		
	MIN	NOM	MAX
A	0.206	0.225	0.244
b	0.015	0.017	0.018
c	0.008	0.009	0.12
D	1.479	1.494	1.509
D1	0.800		
e	0.050 BSC		
S1	--	0.339	--
F1	1.239	1.244	1.249
F2	1.429	1.434	1.439
L	2.485	2.510	2.545
L1	2.485	2.500	2.505
L2	1.690	1.700	1.710
A1	0.180	0.195	0.210
N	68		

Q68-04

Note: All dimensions in inches

16 Megabit (512K x 32-Bit) Low Voltage MCM SRAM 89LV1632

Important Notice:

These data sheets are created using the chip manufacturers published specifications. Maxwell Technologies verifies functionality by testing key parameters either by 100% testing, sample testing or characterization.

The specifications presented within these data sheets represent the latest and most accurate information available to date. However, these specifications are subject to change without notice and Maxwell Technologies assumes no responsibility for the use of this information.

Maxwell Technologies' products are not authorized for use as critical components in life support devices or systems without express written approval from Maxwell Technologies.

Any claim against Maxwell Technologies must be made within 90 days from the date of shipment from Maxwell Technologies. Maxwell Technologies' liability shall be limited to replacement of defective parts.

16 Megabit (512K x 32-Bit) Low Voltage MCM SRAM 89LV1632

Product Ordering Options

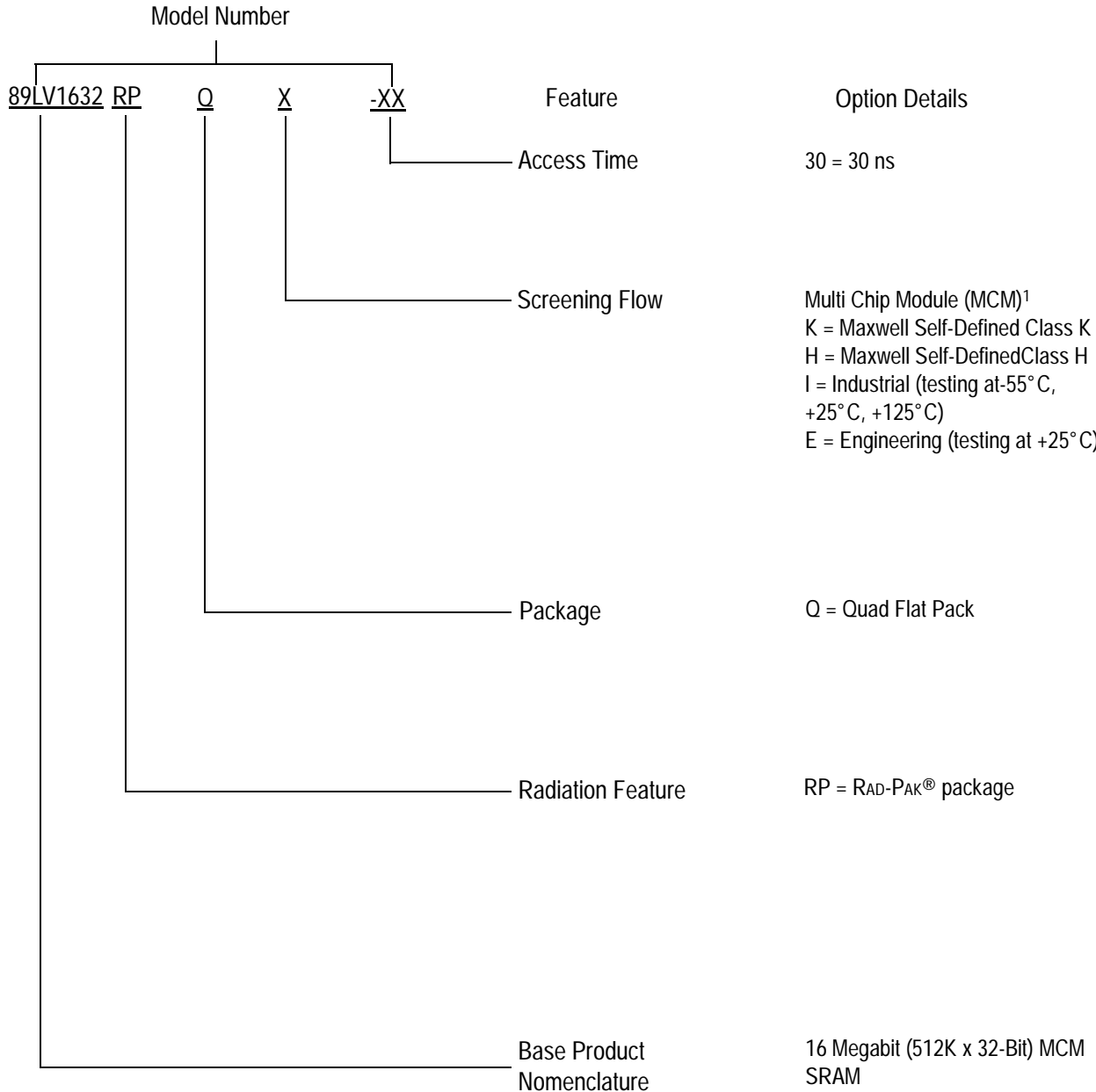

1) Products are manufactured and screened to Maxwell Technologies self-defined Class H and Class K flows.