

Low EMI Spread Spectrum Multiplier Clock

FEATURES

- Spread Spectrum Clock Generator with selectable SST mode.
- Output frequency ranges: 24MHz to 200MHz.
- Selectable Center Spread Modulation.
- TTL/CMOS compatible outputs.
- 3.3V Operating Voltage.
- Low short-term jitter.
- Available in 8-Pin 150mil SOIC.

DESCRIPTION

The ABE0121 is a Spread Spectrum Clock Generator designed for the purpose of reducing EMI in high-speed digital systems, with selectable Center Spread modulation magnitude (see table below). The device operates over a very wide range of input frequencies and provides a 1x modulated clock output.

PIN CONFIGURATION

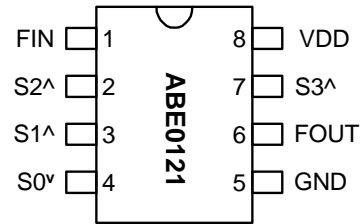

FIN = 24 ~ 200 Mhz

Note: v: 30kΩ Internal Pull down. ^: 30kΩ Internal Pull up.

SST BY-PASS SELECTOR

S3	Spread Spectrum Mode
0	OFF
1	ON (See below) Default

Note: S3 has an internal Pull Up. Default="1"

MODULATION MAGNITUDE SELECTION

S2	S1	S0	FIN Range (MHz)	FOUT	Spread Spectrum Modulation	
					Frequency	Magnitude
0	0	0	24 - 200	X1	Fin / 1024	±0.75%
0	0	1	24 - 200	X1		±1.00%
0	1	0	24 - 200	X1		±1.25%
0	1	1	24 - 200	X1		±0.125%
1	0	0	24 - 200	X1		±0.25%
1	0	1	24 - 200	X1		±0.50%
1	1	0	24 - 200	X1		±0.375%
1	1	1	24 - 200	X1		±0.625%

Low EMI Spread Spectrum Multiplier Clock

BLOCK DIAGRAM

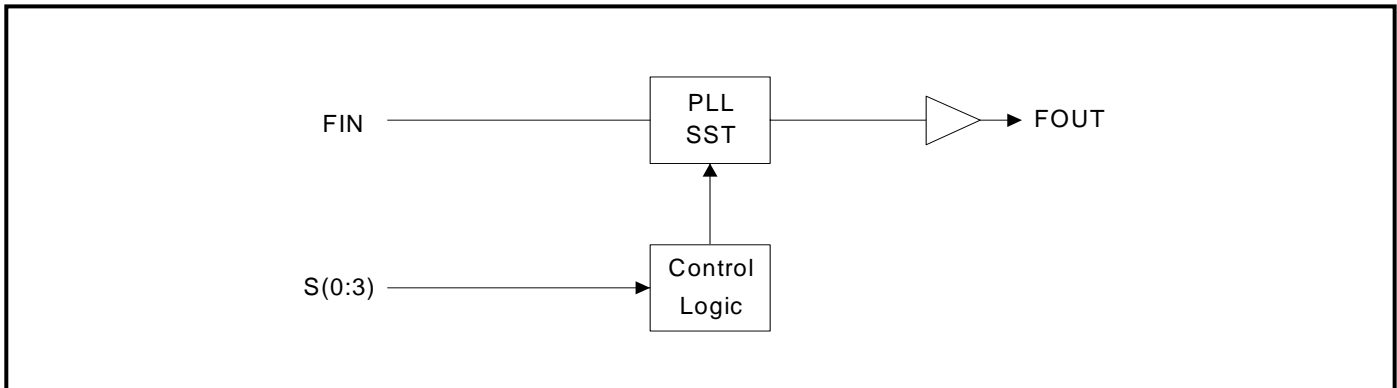

PIN DESCRIPTIONS

Name	Number	Type	Description
FIN	1	I	Input Clock Frequency. 24MHz to 200MHz.
S2	2	I	Digital control input for SST modulation magnitude selection. Has internal pull-up.
S1	3	I	Digital control input for SST modulation magnitude selection. Has internal pull-up.
S0	4	I	Digital control input for SST modulation magnitude selection. Has internal pull-up.
GND	5	P	Ground.
FOUT	6	O	SST Modulated Clock Frequency Output.
S3	7	I	SST By-Pass Selector. S3 has internal pull-up. Default = "1"
VDD	8	P	3.3V Power Supply.

ELECTRICAL SPECIFICATIONS

1. Absolute Maximum Ratings

PARAMETERS	SYMBOL	MIN.	MAX.	UNITS
Supply Voltage	V_{DD}		4.6	V
Input Voltage, dc	V_I	-0.5	$V_{DD}+0.5$	V
Output Voltage, dc	V_O	-0.5	$V_{DD}+0.5$	V
Storage Temperature	T_S	-65	150	°C
Ambient Operating Temperature*	T_A	-40	85	°C
Junction Temperature	T_J		125	°C
Lead Temperature (soldering, 10s)			260	°C
ESD Protection, Human Body Model			2	kV

Exposure of the device under conditions beyond the limits specified by Maximum Ratings for extended periods may cause permanent damage to the device and affect product reliability. These conditions represent a stress rating only, and functional operations of the device at these or any other conditions above the operational limits noted in this specification is not implied.

* Note: Operating Temperature is guaranteed by design for all parts (COMMERCIAL and INDUSTRIAL), but tested for COMMERCIAL grade only.

Low EMI Spread Spectrum Multiplier Clock

2. DC/AC Specifications

PARAMETERS	SYMBOL	CONDITIONS	MIN.	TYP.	MAX.	UNITS
Supply Voltage	V_{DD}		2.97		3.63	V
Input High Voltage	V_{IH}		$0.7 * V_{DD}$			V
Input Low Voltage	V_{IL}				$0.3 * V_{DD}$	V
Input High Current	I_{IH}				100	μA
Input Low Current	I_{IL}				100	μA
Output High Voltage	V_{OH}	$I_{OH}=5mA, V_{DD} =3.3V$	2.4			V
Output Low Voltage	V_{OL}	$I_{OL}=6mA, V_{DD} =3.3V$			0.4	V
Input Frequency	F_{IN}		24		200	MHz
Maximum interruption of F_{IN}					100	μs
Input Capacitance	C_{in1}			4		pF
Pull-up Resistor	R_{pu}	PIN 2, 3, 7		30		$k\Omega$
Pull-down Resistor	R_{pd}	PIN 4		30		$k\Omega$
Short Circuit Current	I_{sc}			50		mA
3.3V Dynamic Supply Current	I_{CC}	No Load		20		mA

3. TIMING CHARACTERISTICS

PARAMETERS	SYMBOL	CONDITIONS	MIN.	TYP.	MAX.	UNITS
Rise Time	T_r	Measured at 0.8V ~ 2.0V @ 3.3V	0.8	0.95	1.1	ns
Fall Time	T_f	Measured at 2.0V ~ 0.8V @ 3.3V	0.78	0.85	0.9	ns
Output Duty Cycle	D_T		45	50	55	%
Input to Output Delay			2		4	ns
Cycle to Cycle Jitter	$T_{cyc-cyc}$	Over output frequency range @ 3.3V			100	ps

FUNCTIONAL DESCRIPTION

Selectable spread spectrum and modulation rates

The ABE0121 provides Center Spread modulation, as well as a selectable modulation magnitude. Selection is made by connecting pins 2 (S2), 3 (S1) and 4 (S0) to a logical "zero" or "one", according to the modulation magnitude selection table on page 1.

Default values for S(0:3) through internal pull-up and pull-down resistor

Selection pin 4 (S0) has an internal pull-down resistor of 30k Ω while pins 2, 3 and 7 (S2, S1 and S3) have an internal pull-up resistor of 30k Ω . This internal pull-down (or pull-up) resistor will pull the input value to a logical "zero" (or "one" respectively) by default, i.e. when no connection is made between the pin and VDD (GND respectively). In order to override the internal pull-down (pull-up), the pin has to be connected to VDD (GND respectively).

Low EMI Spread Spectrum Multiplier Clock

PACKAGE INFORMATION

8 PIN Narrow SOIC (mm)

Symbol	SOIC	
	Min.	Max.
A	1.47	1.73
A1	0.10	0.25
B	0.33	0.51
C	0.19	0.25
D	4.80	4.95
E	3.80	4.00
H	5.80	6.20
L	0.38	1.27
e	1.27 BSC	

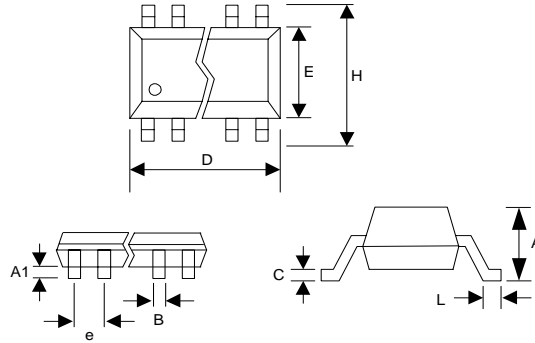

ORDERING INFORMATION

For part ordering, please contact our Sales Department:
 30332 Esperanza., Rancho Santa Margarita, Ca 92688
 Ph: 949-546-8000 Fax: 949-546-8001

PART NUMBER

The order number for this device is a combination of the following:
 Device number, Package type and Operating temperature range

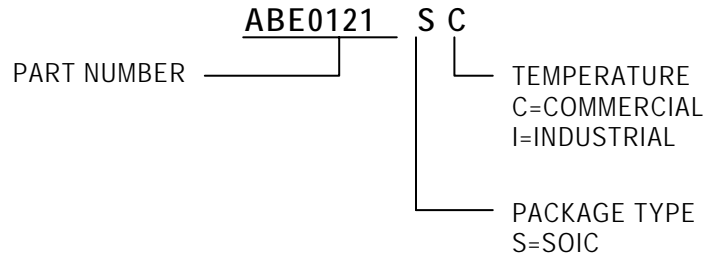

Order Number	Marking	Package Option
ABE0121SC-T	ABE0121SC	SOIC -Tape and Reel
ABE0121SC	ABE0121SC	SOIC -Tube

Abracon Corporation, reserves the right to make changes in its products or specifications, or both at any time without notice. The information furnished by Abracon is believed to be accurate and reliable. However, Abracon makes no guarantee or warranty concerning the accuracy of said information and shall not be responsible for any loss or damage of whatever nature resulting from the use of, or reliance upon this product.

LIFE SUPPORT POLICY: Abracon's products are not authorized for use as critical components in life support devices or systems without the express written approval of the President of Abracon Corporation.