

AC104QF

Ultra Low Power 10/100 Quad RMII Ethernet Transceiver

GENERAL DESCRIPTION

The AC104QF is a highly integrated, 3.3V, low power, four port, 10Base-T/100Base-TX/FX, Ethernet transceiver implemented in 0.35µm CMOS technology. Multiple modes of operation including normal operation, test mode and power saving mode are available through either hardware or software control.

Features include MAC interfaces, ENDECs, Scrambler/Descrambler, and Auto-Negotiation (ANeg) with support for parallel detection. The transmitter includes a dual-speed clock synthesizer that only needs one external clock source. The chip has built-in wave shaping driver circuit for both 10Mbps and 100Mbps, eliminating the need for an external hybrid filter. The receiver has an adaptive equalizer / DC restoration circuit for accurate clock / data recovery for the 100Base-TX signal. It also provides an on-chip low pass filter / Squelch circuit for the 10Base-T signal.

MAC interfaces support four ports of 10/100 RMII.

Media Interfaces support 4 ports of 10/100TX or 3 ports 10/100TX and 1 port 100FX.

FEATURES

- 4 RMII
 - RMII 5Volt tolerant and 2.5Volt capable
- 4 10/100 TX or 3 10/100 TX and 1 100 FX
 - Full Duplex or Half Duplex
 - FEFI on 100FX
- Very small package
 - 100PQFP
- Very low power – TYP < 280mW (/ port)
 - Cable Detect mode – TYP < 40mW (/ port)
 - Power Down mode – TYP < 3.3mW (/ port)
 - Selectable TX drivers for 1:1 or 1.25:1 transformers for additional power reduction
- 3.3Volt .35micron CMOS
- Fully compliant with
 - IEEE 802.3 / 802.3u
 - RMII
 - UNH test labs
- Baseline Wander Compensation
- Multi-Function LED outputs
- Cable length indicator
- Reverse polarity detection and correction with Register Bit indication – Automatic or Forced
- 8 programmable interrupts
- Diagnostic registers

BLOCK DIAGRAM

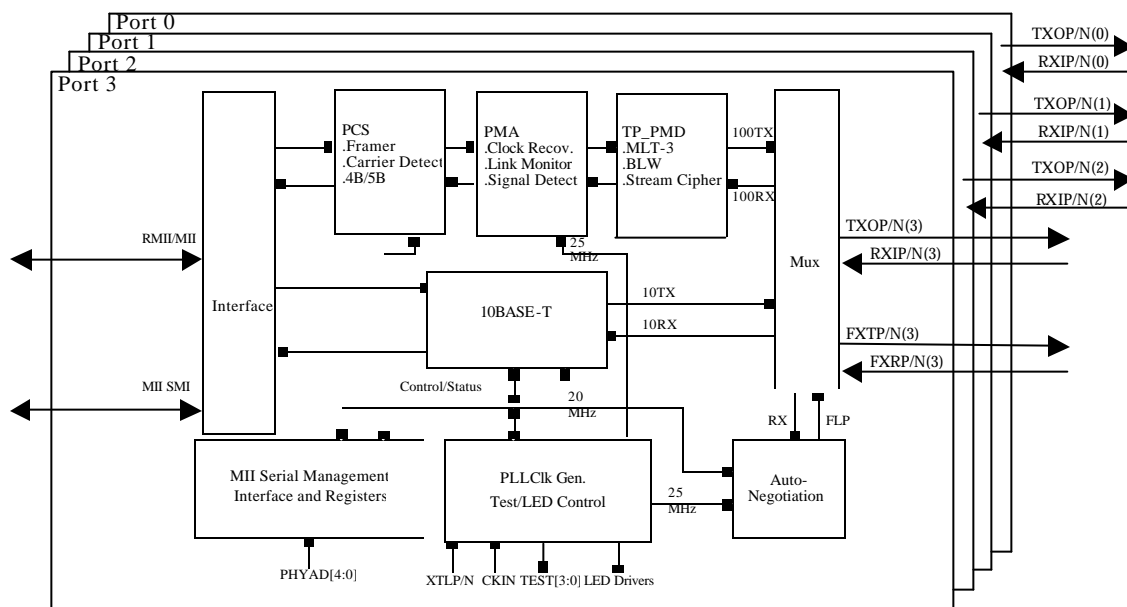

AC104QF
Ultra Low Power 10/100 Quad RMI Ethernet Transceiver

REVISION HISTORY

REVISION#	DATE	CHANGE BY	CHANGE DESCRIPTION
1.0	July 1998	xx	Preliminary Release
3.2	June 2000	xx	Final Release
4.0	Sept 12, 2000	Helene	1. Change the default value of register 3 [15:0] = 101010101000001 on page 20 2. Enhance the descriptions of the DPLX and SPEED (register 18.11 and 18.10) on page 24

AC104QF

Ultra Low Power 10/100 Quad RMII Ethernet Transceiver

General Description	1
Features	1
Block Diagram	1
Pin Diagram - AC104QF	5
Pin Descriptions	6
MDI (Media Dependent Interface) Pins	6
RMII (Reduced Media Independent Interface) Pins	7
SMI (Serial Management Interface) Pins	7
Phy Address Pins	8
Mode Pins	8
LED Pins	8
Power and Ground Pins	9
Functional Description	10
MAC Interface	10
<i>RMII</i>	10
SMI	10
Interrupt	11
Carrier Sense / RX_DV	11
Media Interface	11
<i>10Base-T</i>	11
Transmit Function	11
Receive Function	11
Link Monitor	11
<i>100Base-TX</i>	11
Transmit Function	11
Parallel to Serial, NRZ to NRZI, and MLT3 Conversion	12
Receive Function	12
Baseline Wander Compensation	12
Clock/Data Recovery	12
Decoder/De-scrambler	13
Link Monitor	13
<i>100Base-FX</i>	13
Transmit Function	13
Receive Function	13
Link Monitor	13
Far-End-Fault-Indication (FEFI)	13
<i>10Base-T/100Base-TF/FX</i>	14
Multi-Mode Transmit Driver	14
Adaptive Equalizer	14
PLL Clock Synthesizer	14
Jabber and SQE (Heartbeat)	14
Reverse Polarity Detection and Correction	14
Initialization and Setup	15
<i>Hardware Configuration</i>	15
<i>Software Configuration</i>	15
LEDs	15
<i>Auto-Negotiation</i>	15
<i>Parallel Detection</i>	16
<i>Diagnostics</i>	16
Loopback Operation	16
Cable Length Indicator	16
Reset and Power	16
Clock	17
Register Descriptions	18

AC104QF

Ultra Low Power 10/100 Quad RMII Ethernet Transceiver

<i>Registers 1-7</i>	18
<i>Registers 8-31</i>	18
Register 0: Control Register.....	19
Register 1: Status Register.....	20
Register 2: PHY Identifier 1 Register.....	20
Register 3: PHY Identifier 2 Register.....	20
Register 4: Auto-Negotiation Advertisement Register.....	21
Register 5: Auto-Negotiation Link Partner Ability Register/Link Partner Next Page Message.....	21
Register 6: Auto-Negotiation Expansion Register.....	22
Register 7: Auto-Negotiation Next Page Transmit Register.....	22
Register 16: BT and Interrupt Level Control Register.....	23
Register 17: Interrupt Control/Status Register.....	23
Register 18: Diagnostic Register.....	24
Register 19: Power/Loopback Register.....	24
Register 20: Cable measurement capability Register.....	24
Register 21: Receive Error Counter.....	24
Register 24: Mode Control Register.....	25
Mode Table.....	25
4B/5B Code-Group Table.....	26
SMI Read/Write Sequence.....	27
LED Configurations.....	27
ELECTRICAL CHARACTERISTICS.....	27
ELECTRICAL CHARACTERISTICS.....	28
<i>Absolute Maximum Ratings</i>	28
<i>Operating Range</i>	28
Total Power Consumption.....	28
TTL I/O Characteristics.....	28
REFCLK and XTAL Pins.....	28
I/O Characteristics – LED/CFG Pins.....	29
100 BASE-TX Transceiver Characteristics.....	29
10 BASE-T Transceiver Characteristics.....	29
100 BASE-FX Transceiver Characteristics.....	30
10 BASE-T Link Integrity Timing Characteristics.....	30
<i>Digital Timing Characteristics</i>	31
Power on Reset.....	31
Management Data Interface.....	31
100Base-TX/FX & 10Base-T RMII Transmit System Timing.....	32
100Base-TX/FX & 10Base-T RMII Receive System Timing.....	33
<i>TX Application Termination</i>	34
<i>FX Application Termination</i>	35
<i>Power and ground filtering for AC104QF</i>	36
<i>Package dimensions for AC104QF (100 pin PQFP)</i>	37

AC104QF

Ultra Low Power 10/100 Quad RMII Ethernet Transceiver

PIN DIAGRAM - AC104QF



AC104QF

Ultra Low Power 10/100 Quad RMII Ethernet Transceiver

PIN DESCRIPTIONS

Many of the pins of these devices have multiple functions. The multi-function pins will be designated by **bolding** of the pin number. Separate descriptions of these pins will be listed in the proper sections. Designers must assure that they have identified all modes of operation prior to final design.

NOTES:

The pin assignment shown below and in the pin description table is subject to change without notice. The user is advised to contact **Altima Communications Inc.** before implementing any design based on the information provided in this data sheet.

Signals types:

- I = input
- O = output
- Z = high impedance
- U = internally pull up
- D = internally pull down
- A = analog signal
- * = Active Low Signal
- NC = No Connect pin

MDI (Media Dependent Interface) Pins

Pin Name	Pin #	Type	Description
RXIN(0)	1	AI	Receiver input Negative for both 10Base-T and 100Base-TX.
RXIN(1)	14	AI	
RXIN(2)	17	AI	
RXIN(3)	30	AI	
RXIP(0)	2	AI	Receiver input Positive for both 10Base-T and 100Base-TX.
RXIP(1)	13	AI	
RXIP(2)	18	AI	
RXIP(3)	29	AI	
TXON(0)	6	AO	Transmitter output Negative for both 10Base-T and 100Base-TX.
TXON(1)	9	AO	
TXON(2)	22	AO	
TXON(3)	25	AO	
TXOP(0)	5	AO	Transmitter output Positive for both 10Base-T and 100Base-TX.
TXOP(1)	10	AO	
TXOP(2)	21	AO	
TXOP(3)	26	AO	
FXRP(3)	34	AI/O	Receiver input Positive for 100Base-FX. (Port-3)
FXRN(3)	35	AI/O	Receiver input Negative for 100Base-FX. (Port-3)
FXTTP(3)	36	AO	Transmitter output Positive for 100Base-FX. (Port-3)
FXTN(3)	37	AO	Transmitter output Negative for 100Base-FX. (Port-3)
SDP(3)	32	A/I,O	Signal Detect Input (For port 3 only). Indicates signal quality status on the fiber-optic link in 100Base-FX mode. When the signal quality is good, the SDP pin should be driven high relative to the SDN pin.
SDN(3)	33	A/I,O	

AC104QF
Ultra Low Power 10/100 Quad RMII Ethernet Transceiver

RMII (Reduced Media Independent Interface) Pins

Pin Name	Pin #	Type	Description
TXD[1:0](0)	84, 85	I/O, D	RMII Transmit Data. The MAC will source TXD[1:0](n) synchronous with REFCLK when TX_EN(n) is asserted.
TXD[1:0](1)	74, 75	I/O, D	
TXD[1:0](2)	60, 61	I/O, D	
TXD[1:0](3)	50, 51	I/O, D	
TX_EN(0)	86	I/O, D	RMII Transmit Enable. TX_EN(n) is asserted high by the MAC to indicate that valid data for transmission is presented on the TXD[1:0](n).
TX_EN(1)	76	I/O, D	
TX_EN(2)	63	I/O, D	
TX_EN(3)	53	I/O, D	
RXD[1:0](0)	78,79	I/O, D	RMII Receive Data. The Phy will source RXD[1:0](n) synchronous with REFCLK when CRS_DV(n) is asserted.
RXD[1:0](1)	68,69	I/O, D	
RXD[1:0](2)	55,56	I/O, D	
RXD[1:0](3)	45,46	I/O, D	
CRS_DV(0)	82	I/O, D	CRS_DV(n) is asserted high when media is non-idle.
CRS_DV(1)	71	I/O, D	
CRS_DV(2)	58	I/O, D	
CRS_DV(3)	48	I/O, D	
RX_ER(0)	81	I/O, D	RMII Receive Error. When RX_ER is asserted high, it indicates an error has been detected during frame reception.
RX_ER(1)	70	O	
RX_ER(2)	57	O	
RX_ER(3)	47	I/O, D	
REFCLK	66	I	Reference Clock Input – 50 MHz-100PPM TTL

SMI (Serial Management Interface) Pins

Pin Name	Pin #	Type	Description
MDIO	64	I/O, D	Management Data Input/Output. Bi-directional data interface. 1.5K pull up resistor required (as specified in IEEE-802.3).
MDC	65	I, D	Management Data Clock. 0 to 25 MHz clock sourced by the MAC for transfer of MDIO data.
INTR	94	Z	Interrupt. See Registers 16 and 17 for polarity and sources. The INTR pin has a high impedance output, a 1K Ω pull-up or pull-down resistor is needed.

AC104QF

Ultra Low Power 10/100 Quad RMII Ethernet Transceiver

Phy Address Pins

Pin Name	Pin #	Type	Description
PHYAD_ST	47	I/O,D	1 at reset = 0-XXX00, 1-XXX01, 2-XXX10, 3-XXX11 0 at reset = 0-XXX01, 1-XXX10, 2-XXX11, 3-XXX00
PHYAD [4]	88	I/O	PHY Address [4:2]. These pins set the three MSB's for SMI PHY address. PHYAD [1:0] are internally wired to four ports. (See PHYAD_ST) The PHYAD will also determine the scramble seed, this will help to reduce EMI when there are multiple ports switching at the same time.
PHYAD [3]	89	I/O	
PHYAD [2]	90	I/O	

Mode Pins

Pin Name	Pin #	Type	Description
FX_DIS	91	I/O	FX Disable. Pulled low upon reset will put port 3 in 100FX mode.
TP125	93	I/O	Transformer Ratio. Pulled low upon reset will select transmit transformer ratio to be 1.25:1. Pulled high is 1:1 transformer.
FORCE100	43	I/O	FORCE100: Force 100Base-X Operation. When this signal is pulled high and ANENGA is low upon reset, all ports will be forced to 100Base-TX operation. When asserted low and ANENGA is low, all ports are forced to 10Base-T operation. When ANENGA is high, FORCE100 has no effect on operation.
SCRAM_EN	38	I/O	Scrambler Enable. Pulled low upon reset will bypass the scrambler. Pulled high is scrambler enabled.
ANENGA	39	I/O	Auto-Negotiation Ability. Asserted high means auto-negotiation enable while low means manual selection through FDXEN, F100.
BURN_IN*	40	I/O	Burn-In mode. Burn-in mode for reliability assurance control. This is reserved for internal testing only.

LED Pins

Pin Name	Pin #	Type	Description
LEDDPX[0]	91	I/O,U	Port[n] Duplex LED. Active state indicates Full Duplex or Collision in Half Duplex mode.
LEDDPX[1]	88	I/O,U	
LEDDPX[2]	41	I/O,U	
LEDDPX[3]	38	I/O,U	
LEDACT_LNK[0]	92	I/O,U	Port[n] Activity/Link LED. Active state indicates a valid link. When there is receive or transmit activity, LED will toggle between high and low for 30 ms interval.
LEDACT_LNK[1]	89	I/O,U	
LEDACT_LNK[2]	42	I/O,U	
LEDACT_LNK[3]	39	I/O,U	
LEDSPD[0]	93	I/O,U	Port[n] Speed LED. Active state indicates 100Base-TX mode.
LEDSPD[1]	90	I/O,U	
LEDSPD[2]	43	I/O,U	
LEDSPD[3]	40	I/O,U	
Polarity of LEDs is determined by polarity of mode pins. See LED example			

AC104QF

Ultra Low Power 10/100 Quad RMII Ethernet Transceiver

Miscellaneous Pins

Pin Name	Pin #	Type	Description
RST*	95	I, U	Reset. An active low input will force a known initialization state. The reset pulse duration must be > 100 us. Setting MII Reg. 0.15 will assert software reset, which has the same functionality as the hardware reset.
IBREF	97	A	Reference Bias Resistor. Must be tied to analog ground through an external 10K Ω (1%) resistor.
TST[0] TST[1] TST[2] TST[3]	32 33 34 35	A/I,O	Test. Outputs during test mode.

Power and Ground Pins

Pin Name	Pin #	Type	Description
OVDD	44, 62, 80	P	Digital +3.3V power supply for I/O.
OGND	52, 72, 87	G	Digital ground for I/O.
CVDD	54, 67, 77	P	Digital +3.3V power supply for Core logic.
CGND	49, 59, 73, 83	G	Digital ground for Core logic.
AVDD	7, 8, 15, 16, 23, 24, 31, 100	P	+3.3V power supply for Analog circuit.
AGND	3, 4, 11, 12, 19, 20, 27, 28	G	Ground for Analog circuit.
GAVDD	98,99	P	+3.3V power supply for common analog circuits.
GAGND	96	G	Ground for common analog circuits.

AC104QF

Ultra Low Power 10/100 Quad RMII Ethernet Transceiver

FUNCTIONAL DESCRIPTION

The **AC104QF** physical layer device (Phy) integrates the 100Base-X and 10Base-T functions in a single four port chip that is used in Fast Ethernet 10/100 Mbps applications. The 100Base-X section consists of PCS, PMA, and PMD functions, and the 10Base-T section consists of Manchester ENDEC and transceiver functions. The device performs the following functions:

- 4B/5B
- MLT3
- NRZI
- Manchester Encoding and Decoding
- Clock and Data Recovery
- Stream Cipher Scrambling / De-Scrambling
- Adaptive Equalization
- Line Transmission
- Carrier Sense
- Link Integrity Monitor
- Auto-Negotiation (ANeg)
- RMII MAC connectivity
- MII Management Function

It also provides an RMII consortium compatible Reduced Media Independent Interface (RMII) to communicate with an Ethernet Media Access Controller (MAC). Selection of 10 or 100 Mbps operation is based on the settings of internal Serial Management Interface registers or determined by the on-chip ANeg logic. The device can operate in 10 or 100 Mbps with full duplex or half-duplex mode on a per port basis. Port 3 can also be configured for 100Base-FX.

MAC INTERFACE

RMII

The Reduced Media Independent Interface (RMII) is used to connect the Phy with the MAC. The PHY and MAC obtain their clock from a common 50 MHz source, such as a clock oscillator. This clock is shared by all ports within the Phy for transmitting and receiving data on 2 individual 2-bit data buses. CRS and RXDV are muxed together to indicate to the MAC when there is valid data on the receive bus. In 100M mode RXD[1:0] is sampled on every cycle of REFCLK. In 10M mode RXD[1:0] is sampled on every 10th cycle of REFCLK. RXER is generated by the Phy to indicate a receive error to the MAC. TX_EN is generated by the MAC to indicate to the

Phy when there is valid data on the transmit bus. In 100M mode the Phy will read 2 bits from TXD[1:0] for each cycle of REFCLK. In 10M mode the Phy will read 2 bits of data from TXD[1:0] every 10th cycle of REFCLK.

The Serial Management Interface (SMI) is shared between all ports in the Phy. This totals 7 pins per port plus 3 per Phy, whereas MII has 18 pins per port.

SMI

The Phy's internal registers are accessible only through the MII 2-wire Serial Management Interface (SMI). MDC is a clock input to the Phy which is used to latch in or out data and instructions for the Phy. The clock can run at any speed from DC to 25 MHz. MDIO is a bi-directional connection used to write instructions to, write data to, or read data from the Phy. Each data bit is latched either in or out on the rising edge of MDC. MDC is not required to maintain any speed or duty cycle, provided no half cycle is less than 20ns and that data is presented synchronous to MDC.

MDC/MDIO are a common signal pair to all ports on a design. Therefore, each port needs to have its own unique Physical Address. The Physical Address of the Phy is set using the pins defined as PHYAD[4:2]. These input signals are strapped externally and sampled as reset is negated. PHYAD[1:0] are addressed for each port internal to the Phy. Internal addresses are either 00, 01, 10, 11 or 01, 10, 11, 00 depending on the polarity of PHYAD_ST during reset.

At idle, the PHY is responsible to pull MDIO line to a high state. Therefore, a 1.5K Ohms resistor is required to connect MDIO line to Vcc. The PHYAD can be reprogrammed via software. A detailed definition of the Serial Management registers follows.

At the beginning of a read or write cycle, the MAC will send a continuous 32 bits of one at the MDC clock rate to indicate preamble. A zero and a one will follow to indicate start of frame. A read OP code is a one and a zero, while a write OP code is a zero and a one. These will be followed by 5 bits to indicate PHY address and 5 bits to indicate register address. Then 2 bits follow to allow for turn around time. For read operation, the first bit will be high impedance. Neither the PHY nor the station will assert this bit. During the second bit time, the PHY

AC104QF

Ultra Low Power 10/100 Quad RMII Ethernet Transceiver

will assert this bit to a zero. For write operation, the station will drive a one for the first bit time, and a zero for the second bit time. The 16 bits data field is then presented. The first bit that is transmitted is bit 15 of the register content. (See **SMI Read/Write Sequence**)

Interrupt

The INTR pin on the Phy will be asserted whenever one of 8 selectable interrupt events occur. Assertion state is programmable to either high or low through the INTR_LEVL register bit. Selection is made by setting the appropriate bit in the upper half of the Interrupt Control / Status register. When the INTR bit goes active, the MAC interface is required to read the Interrupt Control / Status register to determine which event caused the interrupt. The Status bits are read only and clear on read. When INTR is not asserted, the pin is held in a high impedance state.

Carrier Sense / RX_DV

Carrier sense is asserted asynchronously on the CRS pins as soon as activity is detected on the receive data stream. RX_DV is asserted as soon as a valid SSD (Start-of-Stream Delimiter) is detected. Carrier sense and RX_DV are de-asserted synchronously upon detection of a valid end of stream delimiter or two consecutive idle code groups in the receive data stream. However, if the carrier sense is asserted and a valid SSD is not detected immediately, RX_ER is asserted instead of RX_DV.

In 10Base-T mode, CRS is asserted asynchronously when the valid preamble and data activity is detected on the RXIP and RXIN pins.

In the half duplex mode, the CRS is activated during the transmit and receiving of data. In the full duplex mode, the CRS is activated during data reception only.

MEDIA INTERFACE

10BASE-T

When configured to run in 10Base-T mode, either through hardware configuration, software configuration or ANeg, the Phy will support all the features and parameters of the industry standards.

Transmit Function

Parallel to Serial logic is used to convert the 2-bit (RMII) or 4-bit (MII) data into the serial stream. The serialized data goes directly to the Manchester encoder where it is synthesized through the output waveshaping driver. The waveshaper reduces any EMI emission by filtering out the harmonics, therefore eliminating the need for an external filter.

Receive Function

The received signal passes through a low-pass filter, which filters out the noise from the cable, board, and transformer. This eliminates the need for a 10Base-T external filter. A Manchester decoder converts the incoming serial stream. Serial to Parallel logic is used to generate the 2-bit (RMII) or 4-bit (MII) data.

Link Monitor

The 10-Base-T link-pulse detection circuit will constantly monitor the RXIP/RXIN pins for the presence of valid link pulses. In the absence of valid link pulses, the Link Status bit will be cleared and the Link LED will de-assert.

100BASE-TX

When configured to run in 100Base-TX mode, either through hardware configuration, software configuration or ANeg, the Phy will support all the features and parameters of the industry standards.

Transmit Function

In 100Base-TX mode, the Phy transmit function converts synchronous 2-bit (RMII) or 4-bit (MII) data to a pair of 125 Mbps differential serial data streams. The serial data is transmitted over network twisted pair cables via an isolation transformer. Data conversion includes 4B/5B encoding, scrambling, parallel to serial, NRZ to NRZI, and MLT-3 encoding. The entire operation is synchronous to 25 MHz and 125 MHz clock. Both clocks are generated by an on-chip PLL clock synthesizer that is locked on to an external 25 MHz clock source.

The transmit data is transmitted from the MAC to the Phy via the TXD[n:0] signals. The 4B/5B encoder replaces the first two nibbles of the preamble from the MAC frame with a /J/K/ code-group pair Start-of-Stream Delimiter (SSD), following the onset of TX_EN signal. The 4B/5B encoder appends a /T/R/ code-group pair End-of-Stream Delimiter (ESD) to the end of transmission in place of the first two IDLE

AC104QF

Ultra Low Power 10/100 Quad RMII Ethernet Transceiver

code-groups that follow the negation of the TX_EN signal. The encapsulated data stream is converted from 4bit nibbles to 5-bit code-groups. During the inter-packet gap, when there is no data present, a continuous stream of IDLE code-groups are transmitted. When TX_ER is asserted while TX_EN is active, the Transmit Error code-group /H/ is substituted for the translated 5B code word. The 4B/5B encoding is bypassed when Reg. 21.1 is set to “1”, or the PCSBP pin is strapped high.

In 100Base-TX mode, the 5-bit transmit data stream is scrambled as defined by the TP-PMD Stream Cipher function in order to reduce radiated emissions on the twisted pair cable. The scrambler encodes a plain text NRZ bit stream using a key stream periodic sequence of 2047 bits generated by the recursive linear function:

$$X[n] = X[n-11] + X[n-9] \text{ (modulo 2)}$$

The scrambler reduces peak emissions by randomly spreading the signal energy over the transmitted frequency range, thus eliminating peaks at any single frequency. For repeater applications, where all ports transmit the same data simultaneously, signal energy is spread further by using a non-repeating sequence for each Phy, i.e., the scrambled seed is unique for each different Phy based on the Phy address.

When Dis_Scrm is set to “0” the data scrambling function is disabled, the 5-bit data stream is clocked directly to the device’s PMA sublayer.

Parallel to Serial, NRZ to NRZI, and MLT3 Conversion

The 5-bit NRZ data is clocked into Phy’s shift register with a 25 MHz clock, and clocked out with a 125 MHz clock to convert it into a serial bit stream. The serial data is converted from NRZ to NRZI format, which produces a transition on Logic 1 and no transition on Logic 0. To further reduce EMI emissions, the NRZI data is converted to an MLT-3 signal. The conversion offers a 3dB to 6dB reduction in EMI emissions. This allows system designers to meet the FCC Class B limit. Whenever there is a transition occurring in NRZI data, there is a corresponding transition occurring in the MLT-3 data. For NRZI data, it changes the count up/down direction after every single transition. For MLT-3 data, it changes the count up/down direction after every two transitions. The NRZI to MLT-3 data conversion is implemented without reference to the bit timing or clock information. The conversion requires detecting the transitions of the incoming NRZI data and setting the count up/down direction

for the MLT-3 data. Asserting FX_SEL high will disable this encoding.

The slew rate of the transmitted MLT-3 signal can be controlled to reduce EMI emissions. The MLT-3 signal after the magnetic has a typical rise/fall time of approximately 4 ns, which is within the target range specified in the ANSI TP- PMD standard. This is guaranteed with either 1:1 or 1.25:1 transformer.

Receive Function

The 100Base-TX receive path functions as the inverse of the transmit path. The receive path includes a receiver with adaptive equalization and DC restoration in the front end. It also includes a MLT-3 to NRZI converter, 125 MHz data and clock recovery, NRZI/NRZ conversion, Serial-to-Parallel conversion, de-scrambler, and 5B/4B decoder. The receiver circuit starts with a DC bias for the differential RX+/- inputs, followed with a low-pass filter to filter out high frequency noise from the transmission channel media. An energy detect circuit is also added to determine whether there is any signal energy on the media. This is useful in the power-saving mode. The amplification ratio and slicer’s threshold is set by the on-chip bandgap reference.

Baseline Wander Compensation

The 100Base-TX data stream is not always DC balanced. The transformer blocks the DC components of the incoming signal, thus the DC offset of the differential receive inputs can drift. The shifting of the signal level, coupled with non-zero rise and fall times of the serial stream can cause pulse-width distortion. This creates jitter and possible increase in the bit error rates. Therefore, a DC restoration circuit is needed to compensate for the attenuation of the DC component. This Phy implements a patent-pending DC restoration circuit. Unlike the traditional implementation, the circuit does not need the feedback information from the slicer or the clock recovery circuit. This design simplifies the circuit design and eliminates any random/systematic offset on the receive path. In the 10BaseT and the 100Base-FX modes, the baseline wander correction circuit is not required, and therefore is disabled.

Clock/Data Recovery

The equalized MLT-3 signal passes through the slicer circuit, and gets converted to NRZI format. The Phy uses a proprietary mixed-signal phase locked loop (PLL) to extract clock information from the incoming NRZI data. The extracted clock is used to re-time the

AC104QF

Ultra Low Power 10/100 Quad RMI Ethernet Transceiver

data stream and set the data boundaries. The transmit clock is locked to the 50 MHz clock input (RMII) or 25 MHz clock input (MII) while the receive clock is locked to the incoming data streams. When initial lock is achieved, the PLL switches to the data stream, extracts the 125 MHz clock, and uses it for the bit framing for the recovered data. The recovered 125 MHz clock is also used to generate the 25 MHz MII_RXC (MII). The PLL requires no external components for its operation and has high noise immunity and low jitter. It provides fast phase alignment and locks to data in one transition. Its data/clock acquisition time after power-on is less than 60 transitions. The PLL can maintain lock on run-lengths of up to 60 data bits in the absence of signal transitions. When no valid data is present, i.e. when the SD is de-asserted, the PLL will switch and lock on to REFCLK. This provides a continuously running MII_RXC (MII). At the PCS interface, the 5 bit data RXD[4:0] is synchronized to the 25 MHz RX_CLK.

Decoder/De-scrambler

The de-scrambler detects the state of the transmit Linear Feedback Shift Register (LFSR) by looking for a sequence representing consecutive idle codes. The de-scrambler acquires lock on the data stream by recognizing IDLE bursts of 30 or more bits and locks its frequency to its de-ciphering LFSR.

Once lock is acquired, the device can operate with an inter-packet-gap (IPG) as low as 40 nS. However, before lock is acquired, the de-scrambler needs a minimum of 270 nS of consecutive idles in between packets in order to acquire lock.

The de-ciphering logic also tracks the number of consecutive errors received while the RX_DV is asserted. Once the error counter exceeds its limit currently set to 64 consecutive errors, the logic assumes that the lock has been lost, and the de-cipher circuit resets itself. The process of regaining lock will start again.

Stream cipher de-scrambler is not used in the 100Base-FX and the 10Base-T modes.

Link Monitor

Signal level is detected through a squelch detection circuitry. A signal detect (SD) circuit allows the equalizer to assert high whenever the peak detector detects a post-equalized signal with peak to ground voltage greater than 400 mV. This is approximately 40% of a normal signal voltage level. In addition, the energy level must be sustained for longer than 2~3

µS in order for the signal detect signal to stay on. The SD gets de-asserted approximately 1~2 µs after the energy level drops consistently below 300 mV from peak to ground.

The link signal is forced low during a local loopback operation (Loopback register bit is set) and forced to high when a remote loopback is taking place (EN_RPBK is set).

In forced 100Base-TX mode, when a cable is unplugged or no valid signal is detected on the receive pair, the link monitor enters in the “link fail” state and NLP's are transmitted. When a valid signal is detected for a minimum period of time, the link monitor enters Link Pass State and transmits MLT-3 signal.

100BASE-FX

When port 3 is configured to run in 100Base-FX mode, either through hardware configuration or software configuration (100Base-FX does not support ANeg) the Phy will support all the features and parameters of the industry standards.

Transmit Function

The serialized data bypasses the scrambler and 4B/5B encoder in FX mode. The output data is NRZI PECL signals. The PECL level signals are used to drive the Fiber-transmitter.

Receive Function

In 100Base-FX mode, signal is received through the PECL receiver inputs, and directly passed to the clock recovery circuit for data/clock extraction. In FX mode, the scrambler/de-scrambler cipher function is bypassed.

Link Monitor

In 100Base-FX mode, the external fiber-optic receiver performs the signal energy detection function and communicates this information directly to the Phy's SDP pin.

Far-End-Fault-Indication (FEFI)

ANeg provides the mechanism to inform the link partner that a remote fault has occurred. However, ANeg is disabled in the 100Base-FX applications. An alternative in-band signaling function (FEFI) is used to signal a remote fault condition. FEFI is a stream of 84 consecutive ones followed by one logic zero. This

AC104QF

Ultra Low Power 10/100 Quad RMII Ethernet Transceiver

pattern is repeated 3 times. A FEFI will signal under 3 conditions: 1) When no activity is received from the link partner, 2) When the clock recovery circuit detects a signal error or PLL lock error, 3) When management entity sets the transmit Far-End-Fault bit.

The FEFI mechanism is enabled by default in the 100Base-FX mode, and is disabled in 100Base-TX or 10Base-T modes. The register setting can be changed by software after reset.

10BASE-T/100BASE-TF/FX

Multi-Mode Transmit Driver

The multi-mode driver transmits the MLT-3 coded signal in 100Base-TX mode, NRZI coded signal in 100Base-FX mode, and Manchester coded signal in 10Base-T mode.

In 100Base-FX mode, no filtering is performed. The transmit driver utilizes a current drive output which is well balanced and produces a low noise PECL signal. PECL voltage levels are produced with resistive terminations.

In 10BaseT mode, high frequency pre-emphasis is performed to extend the cable-driving distance without the external filter. The FLP and NLP pulses are also drive out through the 10BaseT driver.

The 10BaseT and 100BaseTX transmit signals are multiplexed to the transmit output driver. This arrangement results in using the same external transformer for both the 10BaseT and the 100BaseTX. The driver output level is set by a built-in bandgap reference and an external resistor connected to the IBREF pin. The resistor sets the output current for all modes of operation. The TXOP/N outputs are open drain devices with a serial source to I/O pad resistance of 10 Ω max. When the 1:1 transformer is used, the current rating is 40 mA for the 2V_{p-p} MLT-3 signal, and 100 mA for the 5V_{p-p} Manchester signal. One can use a 1.25:1 transmit transformer for a 20% output driver power reduction. This will decrease the drive current to 32 mA for 100Base-TX operation, and 80 mA for 10Base-T operation.

Adaptive Equalizer

The Phy is designed to accommodate a maximum of 150 meters UTP CAT-5 cable. An AT&T 1061 CAT-5 cable of this length typically has an attenuation of 31 dB at 100 MHz. A typical attenuation of 100-

meter cable is 21 dB. The worst case cable attenuation is around 24-26 dB as defined by TP-PMD specification.

The amplitude and phase distortion from the cable cause inter-symbol interference (ISI) which makes clock and data recovery difficult. The adaptive equalizer is designed to closely match the inverse transfer function of the twisted-pair cable. The equalizer has the ability to change its equalizer frequency response according to the cable length. The equalizer will tune itself automatically for any cable, compensating for the amplitude and phase distortion introduced by the cable.

PLL Clock Synthesizer

The Phy includes an on-chip PLL clock synthesizer that generate 25 MHz and 125 MHz clocks for the 100Base-TX circuitry. It also generates 20 MHz and 100 MHz clocks for the 10BaseT and ANeg circuitry. The PLL clock generator uses a fully differential VCO cell that introduces very low jitter. The Zero Dead Zone Phase Detection method implemented in the Phy design provides excellent phase tracking. A charge pump with charge sharing compensation is also included to further reduce jitter at different loop filter voltages. The on-chip loop filter eliminates the need for external components and minimizes the external noise sensitivity. Only one external 50 MHz (RMII) or 25 MHz (MII) crystal or clock source is required as a reference clock.

After power-on or reset, the PLL clock synthesizer generates the 20 MHz clock output until the 100Base-X operation mode is selected.

Jabber and SQE (Heartbeat)

After the MAC transmitter exceeds the jabber timer (46mS), the transmit and loopback functions will be disabled and COL signal get asserted. After TX_EN goes low for more than 500 ms, the TP transmitter will reactivate and COL gets de-asserted. Setting Jabber Disable will disable the jabber function.

When the SQE test is enabled, a COL pulse with 5-15BT is asserted after each transmitted packet. SQE is enabled in 10Base-T by default, and can be disabled via SQE Test Inhibit.

Reverse Polarity Detection and Correction

Certain cable plants have crossed wiring on the twisted pairs; the reversal of TXIN and TXIP. Under normal circumstances this would cause the receive circuitry to reject all data. When the Auto Polarity

AC104QF

Ultra Low Power 10/100 Quad RMII Ethernet Transceiver

Disable bit is cleared, the Phy has the ability to detect the fact that either 8 NLPs or a burst of FLPs are inverted and automatically reverse the receiver's polarity. The polarity state is stored in the Reverse Polarity bit.

If the Auto Polarity Disable bit is set, then the Reverse Polarity bit can be written to force the polarity reversal of the receiver.

INITIALIZATION AND SETUP

HARDWARE CONFIGURATION

Several different states of operation can be chosen through hardware configuration. External pins may be pulled either high or low at reset time. The combination of high and low values determines the power on state of the device.

Many of these pins are multi-function pins which change their meaning when reset ends.

SOFTWARE CONFIGURATION

Several different states of operation can be chosen through software configuration. Please refer to the **SMI** section as well as the **Register Descriptions**.

LEDs

Each of the 4 ports has 3 individual LED outputs available to indicate Speed, Duplex/Collision, and Link/Activity. These multi-function pins are inputs during reset and LED output pins thereafter. The level of these pins during reset determines their active output states. If a multi-function pin is pulled up during reset to select a particular function, then that LED output would become active low, and the LED circuit must be designed accordingly, and vice versa. (See **LED Configuration**.)

AUTO-NEGOTIATION

By definition the 10/100 Transceiver is able to run at either 10Mbps over Twisted Pair Copper (10Base-T), 100Mbps over Twisted Pair Copper (100Base-TX) or 100Mbps over Fiber Optics (100Base-FX). In addition the Phy is able to run in either half duplex (repeater mode) or full duplex. To determine the operational state, the Phy has hardware selects and software selects while also supporting Auto-Negotiation and Parallel Detection. To run in 100Base-FX mode, the selection must be done

through hardware configuration. There is no support for Auto-Negotiation of the FX interface.

Not all of the above combinations are possible due to limitations of the environment and the 802.3 standards. Legitimate operating states are:

- 10Base-T Half Duplex
- 10Base-T Full Duplex
- 100Base-TX Half Duplex
- 100Base-TX Full Duplex
- 100Base-FX Half Duplex (Port 3 only)
- 100Base-FX Full Duplex (Port 3 only)

Only port 3 supports 100Base-FX.

The Phy can be hardware configured to force any one of the above-mentioned modes. By forcing the mode, the Phy will only run in that mode, hence limiting the locations where the product will operate.

The Phy is able to negotiate its mode of operation in the twisted pair environment using the Auto-Negotiation mechanism defined in the clause 28 of IEEE 802.3u specification. ANeg can be enabled or disabled by hardware (ANEGA pin) or software (Reg. 0.12) control. When the ANeg is enabled, the Phy chooses its mode of operation by advertising its abilities and comparing them with the ability received from its link partner. It can be configured to advertise 100Base-TX or 10Base-T operating in either full or half duplex.

Register 4 contains the current capabilities, speed and duplex, of the Phy, determined through hardware selects or chip defaults. The contents of Reg. 4 is sent to its link partner during the ANeg process using Fast Link Pulses (FLPs). An FLP is a string of 1s and 0s, each of which has a particular meaning, the total of which is called a Link Code Word. After reset, software can change any of these bits from 1 to 0 and back to 1, but not from 0 to 1. Therefore, the hardware has priority over software.

When ANeg is enabled, the Phy sends out FLPs during the following conditions:

- power on
- link loss
- restart ANeg command by software

During this period, the Phy continually sends out FLPs while monitoring the incoming FLPs from the link partner to determine their optimal mode of operation. If FLPs are not detected during this phase of operation, Parallel Detection mode is entered (see below).

AC104QF

Ultra Low Power 10/100 Quad RMII Ethernet Transceiver

When the Phy receives 3 identical link code words (ignoring acknowledge bit) from its link partner, it stores these code words in Reg. 5, sets the acknowledge bit in the generated FLPs, and waits to receive 3 identical code word with the acknowledge bit set from the link partner. Once this occurs the Phy configures itself to the highest technology that is common to both ends. The technology priorities are:

1. 100Base-TX, full-duplex
2. 100Base-TX, half-duplex
3. 10Base-T, full-duplex
4. 10Base-T half-duplex.

Once the ANeg is complete, Reg. 1.5 is set, Reg. 1.[14:11] reflects negotiated speed and duplex mode, and the Phy enters the negotiated transmission and reception state. This state will not change until link is lost or the Phy is reset through either hardware or software, or the restart negotiation bit (Reg. 0.9) is set.

PARALLEL DETECTION

Because there are many devices in the field that do not support the ANeg process, but must still be communicated with, it is necessary to detect and link through the Parallel Detection process.

The parallel detection circuit is enabled in the absence of FLPs. The circuit is able to detect:

- Normal Link Pulse (NLP)
- 10Base-T receive data
- 100Base-TX idle

The mode of operation gets configured based on the technology of the incoming signal. If any of the above is detected, the device automatically configures to match the detected operating speed in the half duplex mode. This ability allows the device to communicate with the legacy 10Base-T and 100Base-TX systems, while maintaining the flexibility of Auto-Negotiation.

DIAGNOSTICS

Loopback Operation

Local Loopback and Remote Loopback are provided for testing purpose. They can be enabled by write to either Reg. 0.14 (LPBK) or Reg. 21.3 (EN_RPBK).

The Local Loopback routes transmitted data through the transmit path back to the receiving path's clock and data recovery module. The loopback data are

presented to the PCS in 5 bits symbol format. This loopback is used to check the operation of the 5-bit symbol decoder and the phase locked loop circuitry. In Local Loopback, the SD output is forced to logic one and TXOP/N outputs are tri-stated.

In Remote Loopback, incoming data is passed through the equalizer and clock recovery, then looped back to the NRZI/MLT3 converter and then to the transmit driver. This loopback is used to ensure the device's connection on the media side. It also checks the operation of the device's internal adaptive equalizer, phase locked loop circuit, and wave-shaper synthesizer. During Remote Loopback, signal detect (SD) output is forced to logic zero.

Cable Length Indicator

The Phy can detect the approximate length of the cable it's attached and display the result in Reg. 20.[7:4]. A reading of [0000] translates to < 10m cable used, [0001] translates to ~ 10 meter of cable, and [1111] translates to 150 meter cable. The cable length value can be used by the network manager to determine the proper connectivity of the cable and to manage the cable plant distribution

RESET AND POWER

The Phy can be reset in three ways:

1. During initial power on.
2. Hardware Reset: A logic low signal of 150 μ s pulse width is applied to RST* pin.
3. Software Reset: Write a one to SMI Reg. 0.15.

The power consumption of the device is significantly reduced due to its built-in power management features. Separate power supply lines are used to power the 10BaseT circuitry and the 100BaseTX circuitry. Therefore, the two circuits can be turned-on and turned-off independently. When the Phy is set to operate in 100Base-TX mode, the 10Base-T circuitry is powered down, and vice versa.

The following power management features are supported:

1. Power down mode: This can be achieved by writing to Reg. 0.11 or pulling PWRDN pin high. During power down mode, the device is still be able to interface through the MDC/MDIO management interface.
2. Energy detect / power saving mode: Energy detect mode turns off the power to select internal circuitry when there is no live network

AC104QF

Ultra Low Power 10/100 Quad RMII Ethernet Transceiver

connected. Energy Detect (ED) circuit is always turned on to monitor if there is a signal energy present on the media. The SMI circuitry is also powered on and ready to respond to any management transaction. The transmit circuit still send out link pulses with minimum power consumption. If a valid signal is received from the media, the device will power up and resume normal transmit/receive operation. (Patent Pending)

3. Reduced Transmit Drive Strength mode: Additional power saving can be gained at the Phy level by designing with 1.25:1 turns ration magnetic and asserting the TP125 pin at reset.

CLOCK

The clock input must a TTL clock oscillator measured at 50 MHz-100PPM.

AC104QF
Ultra Low Power 10/100 Quad RMII Ethernet Transceiver

REGISTER DESCRIPTIONS

The first seven registers of the MII register set are defined by the MII specification. In addition to these required registers are several Altima Communications Inc. specific registers. There are reserved registers and/or bits that are for Altima internal use only. The following standard registers are supported. **(Register numbers are in Decimal format, the values are in Hex format):**

NOTE: When writing to registers it is recommended that a read/modify/write operation be performed, as unintended bits may get set to unwanted states. This applies to all registers, including those with reserved bits.

REGISTERS 1-7

Register	Description	Default
0	Control Register	3000
1	Status Register	7849
2	PHY Identifier 1 Register	0022
3	PHY Identifier 2 Register	5541
4	Auto-Negotiation Advertisement Register	01E1
5	Auto-Negotiation Link Partner Ability Register	0001
6	Auto-Negotiation Expansion Register	0004
7	Next Page Advertisement Register	2001

REGISTERS 8-31

Register	Description	Default
8-15	Reserved	XXXX
16	Polarity and Interrupt Level Register	03C0
17	Interrupt Control/Status Register	0000
18	Diagnostic Register	5020
19	Power/Loopback Register	8060
20	Cable Measurement Register	XXXX
21	Receive Error Counter Register	0304
22	Reserved	XXXX
23	Reserved	0000
24	Mode Control Register	0000
25-31	Reserved	XXXX

LEGEND:

RW	Read and Write Access
SC	Self Clearing
LL	Latch Low until cleared by reading
RO	Read Only
RC	Cleared on Read
LH	Latch High until Cleared by reading

AC104QF
Ultra Low Power 10/100 Quad RMII Ethernet Transceiver

Register 0: Control Register

Reg.bit	Name	Description	Mode	Default
0.15	Reset	1 = PHY reset. This bit is self-clearing.	RW/SC	0
0.14	Loopback	1 = Enable loopback mode. This will loopback TXD to RXD and ignore all the activity on the cable media. 0 = Normal operation.	RW	0
0.13	Speed Select	1 = 100Mbps 0 = 10Mbps.	RW	* See Note
0.12	ANeg Enable	1 = Enable Auto-Negotiate process (overrides 0.13 and 0.8) 0 = Disable Auto-Negotiate process. Mode selection is controlled via bit 0.8, 0.13 or through mode pin.	RW	* See Note
0.11	Power Down	1 = Power down. All blocks except for SMI will be turned off. Setting PWRDN pin to high will achieve the same result. 0 = Normal operation.	RW	0
0.10	Isolate	1 = N/A 0 = Normal operation.	R	0
0.9	Restart ANeg	1 = Restart Auto-Negotiation process. 0 = Normal operation.	RW/SC	0
0.8	Duplex Mode	1 = Full duplex. 0 = Half duplex.	RW	* See Note
0.7	Collision Test	1 = Enable collision test, which issues the COL signal in response to the assertion of TX_EN signal. Collision test is disabled if PCSBP pin is high. Collision test is enabled regardless of the duplex mode. 0 = Disable COL test.	RW	0
0.[6:0]	Reserved		RW	000000
* Refer to Mode Table				

AC104QF
Ultra Low Power 10/100 Quad RMII Ethernet Transceiver

Register 1: Status Register

Reg.bit	Name	Description	Mode	Default
1.15	100Base-T4	Permanently tied to zero indicates no 100BaseT4 capability.	RO	0
1.14	100Base-TX Full Duplex	1 = 100BaseTX full duplex capable. 0 = Not 100BaseTX full duplex capable.	RO	* See Note
1.13	100Base-TX Half Duplex	1 = 100BaseTX half duplex capable. 0 = Not TX half-duplex capable.	RO	* See Note
1.12	10Base-T Full Duplex	1 = 10BaseT full duplex capable. 0 = Not 10BaseT full duplex capable.	RO	* See Note
1.11	10Base-T Half Duplex	1 = 10BaseT half duplex capable. 0 = Not 10BaseT half duplex capable.	RO	* See Note
1.[10:7]	Reserved		RO	0000
1.6	MF Preamble Suppression	The Phy is able to perform management transaction without MDIO preamble. The management interface needs minimum of 32 bits of preamble after reset.	RO	1
1.5	ANeg Complete	1 = Auto-Negotiate process completed. Reg. 4, 5, 6 are valid after this bit is set. 0 = Auto-negotiate process not completed.	RO	0
1.4	Remote Fault	1 = Remote fault condition detected. 0 = No remote fault. This bit will remain set until it is cleared by reading register 1.	RO/LH	0
1.3	ANeg Ability	1 = Able to perform Auto-Negotiation function, default value determined by ANEGA pin. 0 = Unable to perform Auto-Negotiation function.	RO	ANEGA
1.2	Link Status	1 = Link is established. If link fails, this bit will be cleared and remain at 0 until register is read again. 0 = Link has gone down.	RO/LL	0
1.1	Jabber Detect	1 = Jabber condition detect. 0 = No Jabber condition detected.	RO/LH	0
1.0	Extended Capability	1 = Extended register capable. This bit is tied permanently to one.	RO	1
* Refer to Mode Table				

Register 2: PHY Identifier 1 Register

Reg.bit	Name	Description	Mode	Default
2.[15:0]	OUI*	Composed of the 3rd through 18th bits of the Organizationally Unique Identifier (OUI), respectively.	RO	0022(H)
* = Based on an OUI is 0010A9 (Hex)				

Register 3: PHY Identifier 2 Register

Reg.bit	Name	Description	Mode	Default
3.[15:10]	OUI	Assigned to the 19th through 24th bits of the OUI.	RO	010101
3.[9:4]	Model Number	Six bit manufacturer's model number. 101 is encoded as 010001.	RO	010100
3.[3:0]	Revision Number	Four-bit manufacturer's revision number. 0001 stands for Rev. B, etc.	RO	0001
* = Based on an OUI of 0010A9 (Hex)				

AC104QF
Ultra Low Power 10/100 Quad RMII Ethernet Transceiver

Register 4: Auto-Negotiation Advertisement Register

Reg.bit	Name	Description	Mode	Default
4.15	Next Page	1 = Next Page enabled. 0 = Next Page disabled.	RW	0
4.14	Acknowledge	This bit will be set internally after receiving 3 consecutive and consistent FLP bursts.	RO	0
4.13	Remote Fault	1 = Advertises that this device has detected a Remote Fault. 0 = No remote fault detected.	RW	0
4.[12:11]	Reserved	For future technology.	RW	000
4.10	FDFC	Full Duplex Flow Control 1= Advertise that the DTE(MAC) has implemented both the optional MAC control sublayer and the pause function as specified in clause 31 and annex 31B of 802.3u. 0= MAC does not support flow control		
4.9	100Base-T4	Technology not supported. This bit always 0	RO	0
4.8	100Base-TX Full Duplex	1 = 100BaseTX full duplex capable. 0 = Not 100BaseTX full duplex capable.	RW	* See Note
4.7	100Base-TX	1 = 100BaseTX half duplex capable. 0 = Not TX half duplex capable.	RW	* See Note
4.6	10Base-T Full Duplex	1 = 10BaseT full duplex capable. 0 = Not 10BaseT full duplex capable.	RW	* See Note
4.5	10Base-T	1 = 10BaseT half duplex capable. 0 = Not 10BaseT half duplex capable.	RW	* See Note
4.[4:0]	Selector Field	Protocol Selection [00001] = IEEE 802.3.	RO	00001

* refer to Mode Table

Register 5: Auto-Negotiation Link Partner Ability Register/Link Partner Next Page Message

Reg.bit	Name	Description	Mode	Default
5.15	Next Page	1 = Link partner desires Next Page transfer. 0 = Link partner does not desire Next Page transfer.	RO	0
5.14	Acknowledge	1 = Link Partner acknowledges reception of FLP words. 0 = Not acknowledged by Link Partner.	RO	0
5.13	Remote Fault	1 = Remote Fault indicated by Link Partner. 0 = No remote fault indicated by Link Partner.	RO	0
5.[12:10]	Reserved	For future technology.	RO	000
5.9	100Base-T4	1 = 100BaseT4 supported by Link Partner. 0 = 100BaseT4 not supported by Link Partner.	RO	0
5.8	100Base-TX Full Duplex	1 = 100BaseTX full duplex supported by Link Partner. 0 = 100BaseTX full duplex not supported by Link Partner.	RO	0
5.7	100Base-TX	1 = 100BaseTX half duplex supported by Link Partner. 0 = 100BaseTX half duplex not supported by Link Partner.	RO	0
5.6	10Base-T Full Duplex	1 = 10Mbps full duplex supported by Link Partner. 0 = 10Mbps full duplex not supported by Link Partner.	RO	0
5.5	10Base-T	1 = 10Mbps half duplex supported by Link Partner. 0 = 10Mbps half duplex not supported by Link Partner.	RO	0
5.[4:0]	Selector Field	Protocol Selection [00001] = IEEE 802.3.	RO	00001

*When this register is used as Next Page Message, the bit definition is the same as Register 7.

AC104QF
Ultra Low Power 10/100 Quad RMII Ethernet Transceiver

Register 6: Auto-Negotiation Expansion Register

Reg.bit	Name	Description	Mode	Default
6.[15:5]	Reserved		RO	0
6.4	Parallel Detection Fault	1 = Fault detected by parallel detection logic, this fault is due to more than one technology detecting concurrent link up condition. This bit can only be cleared by reading Register 6 using the management interface. 0 = No fault detected by parallel detection logic.	RO/LH	0
6.3	Link Partner Next Page Able	1 = Link partner supports next page function. 0 = Link partner does not support next page function.	RO	0
6.2	Next Page Able	Next page is supported.	RO	1
6.1	Page Received	This bit is set when a new link code word has been received into the Auto-Negotiation Link Partner Ability Register. This bit is cleared upon a read of this register.	RC	0
6.0	Link Partner ANeg-Able	1 = Link partner is Auto-Negotiation capable. 0 = Link partner is not Auto-Negotiation capable.	RO	0

Register 7: Auto-Negotiation Next Page Transmit Register

Reg.bit	Name	Description	Mode	Default
7.15	NP	1 = Another Next Page desired. 0 = No other Next Page Transfer desired.	RW	0
7.14	Reserved		RO	0
7.13	MP	1 = Message page. 0 = Un-formatted page.	RW	1
7.12	ACK2	1 = Will comply with message. 0 = Cannot comply with message.	RW	0
7.11	TOG_TX	1 = Previous value of transmitted link code word equals to 0. 0 = Previous value of transmitted link code word equals to 1.	RW	0
17.[10:0]	CODE	Message/Un-formatted Code Field.	RW	001

AC104QF
Ultra Low Power 10/100 Quad RMII Ethernet Transceiver

Register 16: BT and Interrupt Level Control Register

Reg.bit	Name	Description	Mode	Default
16.15	Reserved		RW	0
16.14	INTR_LEVL	1=INTR pin will be active high. 0=INTR pin will be active low.	RW	0
16.13	TXJAM	1 = Force CIM to send JAM pattern 0 = Normal operation	RW	0
16.12	Reserved		RO	0
16.11	SQE Test Inhibit	1 = Disable 10BaseT SQE testing. 0 = Enable 10BaseT SQE testing, which will generate a COL pulse following the completion of a packet transmission.	RW	0
16.[10:6]	Reserved		RO	0
16.5	Auto Polarity Disable	1 = Disable Auto Polarity detection/correction. 0 = Enable Auto Polarity detection/correction.	RW	0
16.4	Reverse Polarity	1= Reverse Polarity when Reg. 16.5 = 0 0= Normal Polarity when Reg. 16.5 = 0 If Reg. 16.5 is set to 1, writing a one to this bit will reverse the polarity of the transmitter.	RW	0
16.[3:0]	Reserved		RO	0

Register 17: Interrupt Control/Status Register

Reg.bit	Name	Description	Mode	Default
17.15	Jabber_IE	Jabber Interrupt Enable.	RW	0
17.14	Rx_Er_IE	Receive Error Interrupt Enable.	RW	0
17.13	Page_Rx_IE	Page Received Interrupt Enable.	RW	0
17.12	PD_Fault_IE	Parallel Detection Fault Interrupt Enable.	RW	0
17.11	LP_Ack_IE	Link Partner Acknowledge Interrupt Enable.	RW	0
17.10	Link_Not_OK_IE	Link Status Not OK Interrupt Enable.	RW	0
17.9	R_Fault_IE	Remote Fault Interrupt Enable.	RW	0
17.8	ANeg_Comp_IE	Auto-Negotiation Complete Interrupt Enable.	RW	0
17.7	Jabber_Int	This bit is set when a jabber event is detected.	RC	0
17.6	Rx_Er_Int	This bit is set when RX_ER transitions high.	RC	0
17.5	Page_Rx_Int	This bit is set when a new page is received during ANeg.	RC	0
17.4	PD_Fault_Int	This bit is set when parallel detect fault is detected.	RC	0
17.3	LP_Ack_Int	This bit is set when the FLP with acknowledge bit set is received.	RC	0
17.2	Link_Not_OK Int	This bit is set when link status switches from OK status to Non-OK status (Fail or Ready).	RC	0
17.1	R_Fault_Int	This bit is set when remote fault is detected.	RC	0
17.0	ANeg_Comp Int	This bit is set when ANeg is complete.	RC	0

AC104QF
Ultra Low Power 10/100 Quad RMII Ethernet Transceiver

Register 18: Diagnostic Register

Reg.bit	Name	Description	Mode	Default
18.[15:12]	Reserved		RO	0
18.11	DPLX	The result of Auto-negotiation: Full-duplex =1; Half-duplex = 0	RO	0
18.10	Speed	The result of Auto-neg. for speed: 100base-TX = 1; 10Base-T = 0.	RO	0
18.9	RX_PASS	In 10BT mode, this bit indicates that Manchester data has been detected. In 100BT mode, it indicates valid signal has been received but not necessarily locked on to.	RO	0
18.8	RX_LOCK	Indicates the receive PLL has locked onto the received signal for the selected speed of operation (10Base-T or 100Base-TX). This bit is set whenever a cycle-slip occurs, and will remain set until it is read.	RO/RC	0
18.[7:0]	Reserved		RO	0

Register 19: Power/Loopback Register

Reg.bit	Name	Description	Mode	Default
19.[14:7]	Reserved	Reserved	RW	00
19.6	TP125	Transmit transformer ratio selection. 1 = 1.25:1 0 = 1:1 The default value of this bit is controlled by TP125 pin.	RW	0
19.5	Low Power Mode	1 = Enable advanced power saving mode. 0 = Disable advanced power saving mode.	RW	1
19.[4:2]	Reserved	Reserved	RW	00
19.1	NLP Link Integrity Test	1 = In ANeg test mode, send NLP instead of FLP in order to test NLP receive integrity. 0 = Sending FLP in ANeg test mode.	RW	0
19.0	Reserved	Reserved	RW	0

Register 20: Cable measurement capability Register

Reg.bit	Name	Description	Mode	Default
20.[15:8]	Reserved		RO	0
20.[7:4]	Cable measurement capability	These bits can be used as cable length indicator. The bits are incremented from 0000 to 1111, with an increment of approximately 10 meters. The equivalent is 0 to 32 dB with an increment of 2 dB @ 100 MHz. The value is a read back from the equalizer, and the measured value is not absolute.	RO	0
20.[3:0]	Reserved		RO	0

Register 21: Receive Error Counter

Reg.bit	Name	Description	Mode	Default
21.[15:0]	RX_ER Counter	Count Receive Error Events	RO	0

AC104QF
Ultra Low Power 10/100 Quad RMII Ethernet Transceiver

Register 24: Mode Control Register

Reg.bit	Name	Description	Mode	Default
24.15	SDCM_Sel	Select Common Mode Voltage for FX Signal Detect. 1 = Select internal common mode setting. 0 = Select external common mode setting.	RO	0
24.14	NLP_Disable	1 = Force 10B-T link up without checking NLP. 0 = Normal Operation.	RW	0
24.13	Force_link_up	1 = Ignore link in 100Base-TX and transmit data. ANeg must be disabled at this time (ANEGA pin tied low). 0 = Normal Operation.	RW	0
24.12	Jabber_Disable	1 = Disable Jabber function in PHY. 0 = Enable Jabber function in PHY.	RW	0
24.11	Reserved		RO	0
24.10	Conf_ALED	1 = Activity LED only responds to receive operation. 0 = Activity LED responds to receive and transmit. This bit should be ignored when Reg. 0.8 is set one.	RW	0
24.9	Reserved		RO	0
24.8	FEF_Disable	1 = Disable Far End Fault Insertion. 0 = Enable Far End Fault Insertion and detection function. This bit valid when FX mode is enabled.	RW	Set by FORCE 100
24.7	Force FEF Transmit	1 = Force transmission of Far End Fault Insertion pattern. 0 = Normal operation.	RW	0
24.6	Rx_Er_Cnt Full	1 = Receive Error Counter full. 0 = Receive Error Counter not full.	RO/ RC	0
24.5	Disable Rx_Er_Cnt	1 = Disable Receive Error Counter. 0 = Enable Receive Error Counter.	RW	0
24.4	Dis_WDT	1 = Disable the watchdog timer in the decipher. 0 = Enable watchdog timer.	RW	0
24.3	En_RPBK	1 = Enable remote loopback. 0 = Disable remote loopback.	RW	0
24.2	Dis_Scrm	1 = Enable 100M data scrambling. 0 = Disable 100M data scrambling. When FX mode is selected, this bit will be forced to zero.	RW	Set by SCRAM_EN
24.1	Reserved		RO	0
24.0	FX_SEL	1 = FX mode selected. 0 = Disable FX mode.	RW	Set by !FX_DIS

Mode Table

FX_Dis	Force 100	Scram_En	ANEGA	Condition
0	X	1	1	Port 3 100Base-FX Port 0-2 Auto Negotiate 10Base-T or 100Base-TX
1	X	1	1	Port 0-3 Auto Negotiate 10Base-T or 100Base-TX
1	1	1	0	Port 0-3 Forced to 100Base-TX
1	0	1	0	Port 0-3 Forced to 10Base-T
1	1	0	0	Port 0-3 Forced to 100Base-TX (unscrambled)

AC104QF
Ultra Low Power 10/100 Quad RMII Ethernet Transceiver

4B/5B CODE-GROUP TABLE

PCS Code Group[4:0]	SYMBOL Name	MII (TXD/RXD [3:0])	Description
11110	0	0000	Data 0
01001	1	0001	Data 1
10100	2	0010	Data 2
10101	3	0011	Data 3
01010	4	0100	Data 4
01011	5	0101	Data 5
01110	6	0110	Data 6
01111	7	0111	Data 7
10010	8	1000	Data 8
10011	9	1001	Data 9
10110	A	1010	Data A
10111	B	1011	Data B
11010	C	1100	Data C
11011	D	1101	Data D
11100	E	1110	Data E
11101	F	1111	Data F
Idle and Control Code			
11111	I	0000	Inter-Packet Idle; used as inter-stream fill code.
11000	J	0101	Start of stream delimiter, part 1 of 2; always use in pair with K symbol.
10001	K	0101	Start of stream delimiter, part 2 of 2; always use in pair with J symbol.
01101	T	Undefined	End of stream delimiter, part 1 of 2; always use in pair with R symbol.
00111	R	Undefined	End of stream delimiter, part 2 of 2; always use in pair with T symbol.
Invalid Code			
00100	H	Undefined	Transmit Error; used to send HALT code-group
00000	V	Undefined	Invalid code
00001	V	Undefined	Invalid code
00010	V	Undefined	Invalid code
00011	V	Undefined	Invalid code
00101	V	Undefined	Invalid code
00110	V	Undefined	Invalid code
01000	V	Undefined	Invalid code
01100	V	Undefined	Invalid code
10000	V	Undefined	Invalid code
11001	V	Undefined	Invalid code

AC104QF
Ultra Low Power 10/100 Quad RMII Ethernet Transceiver

SMI READ/WRITE SEQUENCE

SMI Read/Write Sequence								
	Pream (32 bits)	Start (2 bits)	OpCode (2 bits)	PHYAD (5 bits)	REGAD (5 bits)	TurnAround (2 bits)	Data (16 bits)	Idle
Read	1...1	01	10	AAAAA	RRRRR	Z0	D...D	Z
Write	1...1	01	01	AAAAA	RRRRR	10	D...D	Z

LED CONFIGURATIONS

Mode	LEDDPX	LEDACT	LEDSPD
10M Link		ON	OFF
10M HDX Transmit	OFF	TOGGLE	OFF
10M HDX Receive	OFF	TOGGLE	OFF
10 HDX Collision	ON during collision	TOGGLE	OFF
10M FDX Transmit	ON	TOGGLE	OFF
10M FDX Receive	ON	TOGGLE	OFF
100M Link		ON	ON
100M HDX Transmit	OFF	TOGGLE	ON
100M HDX Receive	OFF	TOGGLE	ON
100 HDX Collision	ON during collision	TOGGLE	ON
100M FDX Transmit	ON	TOGGLE	ON
100M FDX Receive	ON	TOGGLE	ON

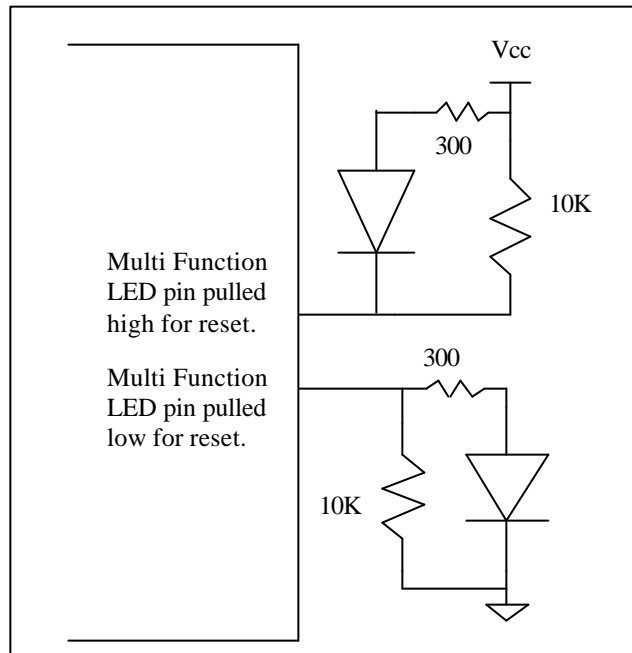

AC104QF
Ultra Low Power 10/100 Quad RMII Ethernet Transceiver

ELECTRICAL CHARACTERISTICS

NOTE: The following electrical characteristics are design goals rather than characterized numbers.

ABSOLUTE MAXIMUM RATINGS

Storage Temperature..... -55°C to +150°C
Vcc Supply Referenced to GND..... -0.5V to +5.0V
Digital Input Voltage..... -0.5V to Vcc
DC Output Voltage..... -0.5V to Vcc

OPERATING RANGE

Operating Temperature(Ta) -40°C to +85°C
Vcc Supply Voltage Range(Vcc) 2.97V to 3.63V

Total Power Consumption

Parameter	Symbol	Conditions	Min	Typ	Max	Units
Supply Current (per port)	Icc	10 Base-T, Idle		25	30	mA
		10 Base-T, Normal activity		41	75	mA
		100 Base-TX		85	100	mA
		100 Base-FX		30	40	mA
		10/100 Base-TX, low power without cable		12	15	mA
		Power down			1	mA

TTL I/O Characteristics

Parameter	Symbol	Conditions	Min	Typ	Max	Units
Input Voltage High	Vih		2.0			V
Input Voltage Low	Vil				0.8	V
Input Current	Ii		-10		10	mA
Output Voltage High	Voh		VCC-0.4			V
Output Voltage Low	Vol				0.4	V
Output Current High	Ioh				8	mA
Output Current Low	Iol		-8			mA
Input Capacitance	Ci			10		pF
Output Transition Time		3.15V < VCC < 3.45V		5		ns
Tristate Leakage Current	Ioz				10	uA

REFCLK and XTAL Pins

Parameter	Symbol	Conditions	Min	Typ	Max	Units
Input Voltage Low	Vil				0.8	V
Input Voltage High	Vih		2.0			V
Input Clock Frequency Tolerance	F				±50	ppm
Input Clock Duty Cycle	Tdc		40		60	%
Input Capacitance	Cin			3.0		pF

AC104QF
Ultra Low Power 10/100 Quad RMII Ethernet Transceiver

I/O Characteristics – LED/CFG Pins

Parameter	Symbol	Conditions	Min	Typ	Max	Units
Output Low Voltage	V _{ol}				0.4	V
Output High Voltage	V _{oh}		2.4			V
Input Current	I _i		-8		8	mA
Output Current	I _o		-10		10	mA

100 BASE-TX Transceiver Characteristics

Parameter	Symbol	Conditions	Min	Typ	Max	Units
Peak to Peak Differential Output Voltage	V _p	Note 1	1.9	2.0	2.1	V
Output Voltage Symmetry	V _{ss}	Note 1	.98		1.02	mV
Signal Rise/Fall Time	Tr _f	Note 1	3.0		5.0	ns
Rise/Fall Time Symmetry	Tr _{fs}	Note 1	3	4	4	ns
Duty Cycle Distortion	D _{cd}				±250	ps
Overshoot/Undershoot	V _{os}				5	%
Output Jitter		Scrambled Idle			1.4	ns
Receive Jitter Tolerance					4	ns
Output Current High	I _{oh}	1:1 Transformer			40	mA
Output Current High	I _{oh}	1.25:1 Transformer			32	mA
Common Mode Input Voltage				1.8		V
Common Mode Input Current					10	uA
Differential Input Resistance				5		KΩ
Note 1: 50Ω (± 1%) resistor to VCC on each output						

10 BASE-T Transceiver Characteristics

Parameter	Symbol	Conditions	Min	Typ	Max	Units
Peak to Peak Differential Output Voltage	V _{op}	Note 1	4.5	5	5.5	V
Signal Rise/Fall Time			1		4	ns
Output Current Sink				15	16	mA
Output Current High	I _{oh}	1:1 Transformer			100	mA
Output Current High	I _{oh}	1.25:1 Transformer			80	mA
Start of Idle Pulse Width			300		350	ns
Output Jitter					1.4	ns
Receive Jitter Tolerance					32	ns
Receive Input Impedance	Z _{in}		3.6			KΩ
Differential Squelch Threshold	V _{ds}		300	400	500	mV
Common Mode Rejection				25		V
Differential Input Resistance			25			KΩ
Note 1: 50Ω (± 1%) resistor to VCC on each output						

AC104QF
Ultra Low Power 10/100 Quad RMII Ethernet Transceiver

100 BASE-FX Transceiver Characteristics

Parameter	Symbol	Conditions	Min	Typ	Max	Units
Differential Output Voltage High	Voh	Note 1	2.2		2.5	V
Differential Output Voltage Low	Vol	Note 1	1.4		1.7	V
Signal Rise/Fall Time			1		4	ns
Output Jitter					1.4	ns
Differential Output Voltage High	Vih		2.1		2.4	V
Differential Output Voltage Low	Vil		1.5		1.8	V
Common-Mode Input Voltage			1.3		3.1	V
Input Differential			150			mV
Output Current Sink				15	16	mA
Note 1: 69Ω to 3.3V VCC and 183Ω to ground						

10 BASE-T Link Integrity Timing Characteristics

Parameter	Symbol	Conditions	Min	Typ	Max	Units
Time Link Loss Receiver			50		150	ms
Link Pulse			2		7	Link Pulses
Link Min Receive Timer			2		7	ms
Link Max Receive Timer			50		150	ms
Link Transmit Period			8		24	ms
Link Pulse Width			60		150	ns

AC104QF
Ultra Low Power 10/100 Quad RMII Ethernet Transceiver

DIGITAL TIMING CHARACTERISTICS

Power on Reset

Parameter	SYM	Conditions	Min	Typ	Max	Units
RST* Low Period	tRST		150	-	-	μs
Configuration	tCONF		100	-	-	ns

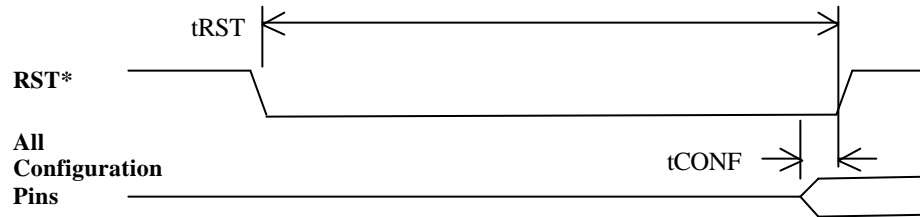

Power on Reset Timing

Management Data Interface

Parameter	SYM	Conditions	Min	Typ	Max	Units
Mgt CLOCK	tMDCL		20	-	-	ns
Mgt CLOCK	tMDCH		20	-	-	ns
MDIO Setup	tMS	Setup on Read/Write Cycle	10	-	-	ns
MDIO Hold	tMH	Hold on Read/Write Cycle	10			ns

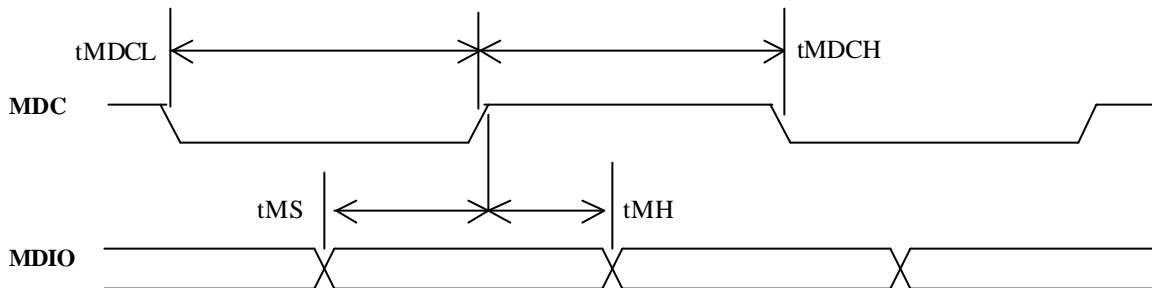

Management Data Interface Timing

AC104QF

Ultra Low Power 10/100 Quad RMII Ethernet Transceiver

100Base-TX/FX & 10Base-T RMII Transmit System Timing

Parameter	SYM	Conditions	Min	Typ	Max	Units
REFCLK period	tCK		19.999	20.000	20.001	ns
REFCLK High period	tCKH		9.000	10.000	11.000	ns
REFCLK Low period	tCKL		9.000	10.000	11.000	ns
TX_EN to /J/ (SOP)	tTJ		60	-	100	ns
!TX_EN to /T/ (EOP)	tTT		60	-	100	ns
TX Propagation Delay	tTJ	From TXD[1:0] to TXOP/N(_FX)	60	-	100	ns
TXD[1:0], TX_EN Setup	tTXS	From rising edge of REFCLK	4	-	-	ns
TXD[1:0], TX_EN Hold	tTXH	From rising edge of REFCLK	0	-	2	ns
!TX_EN to TX_EN	tTX_TX		120	-	-	ns

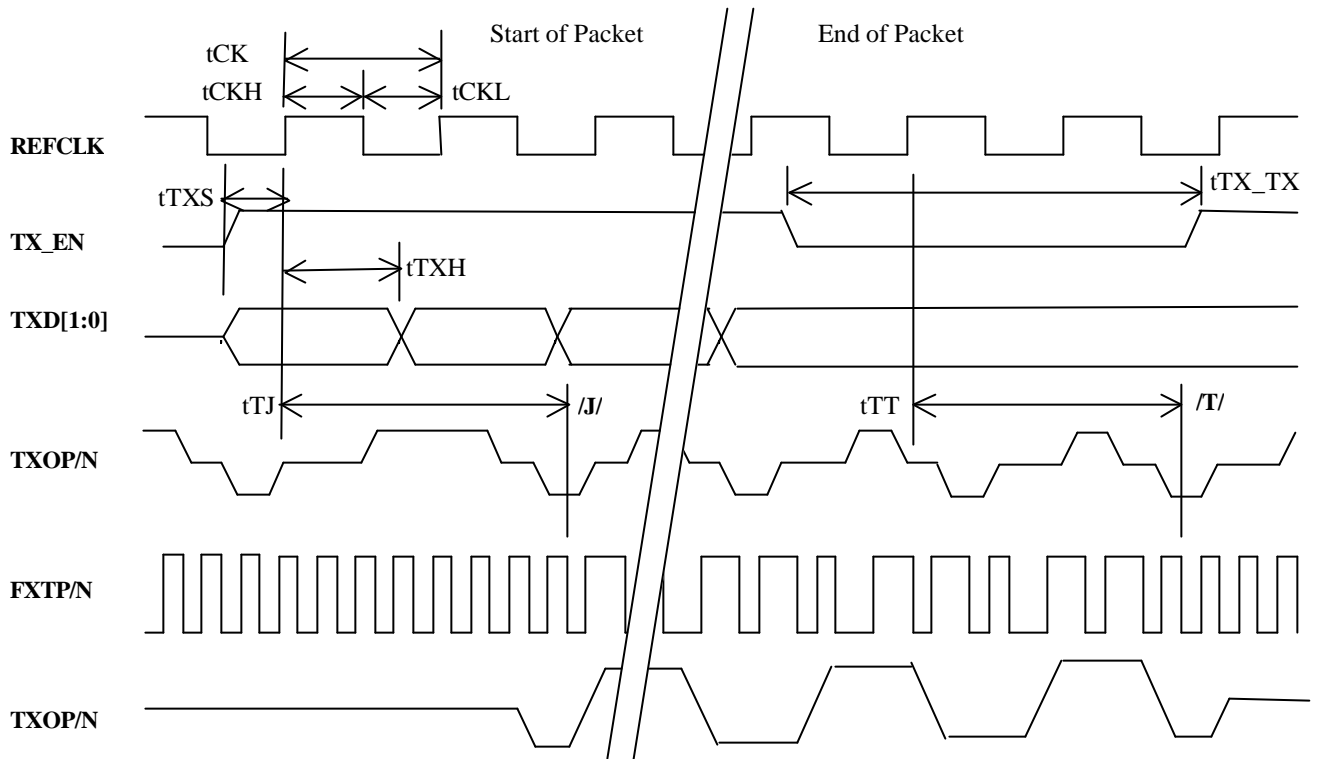

100Base-TX/FX & 10Base-T RMII Transmit Timing

AC104QF

Ultra Low Power 10/100 Quad RMII Ethernet Transceiver

100Base-TX/FX & 10Base-T RMII Receive System Timing

Parameter	SYM	Conditions	Min	Typ	Max	Units
REFCLK period	tCK		19.999	20.000	20.001	ns
REFCLK High period	tCKH		9.000	10.000	11.000	ns
REFCLK Low period	tCKL		9.000	10.000	11.000	ns
/J/K (SOP) to CRS_DV	tRCSA		80	-	150	ns
/T/R (EOP) to !CRS_DV	tRCSD		120	-	190	ns
RX Propagation Delay	tRDVA	From RXIP/N(!_FX) to RXD[1:0]	-	40	180	ns
RXD[1:0], CRS_DV, RX_ER Setup	tRXS	From rising edge of REFCLK	4	-	-	ns
RXD[1:0], CRS_DV, RX_ER Hold	tRXH	From rising edge of REFCLK	5	-	-	ns

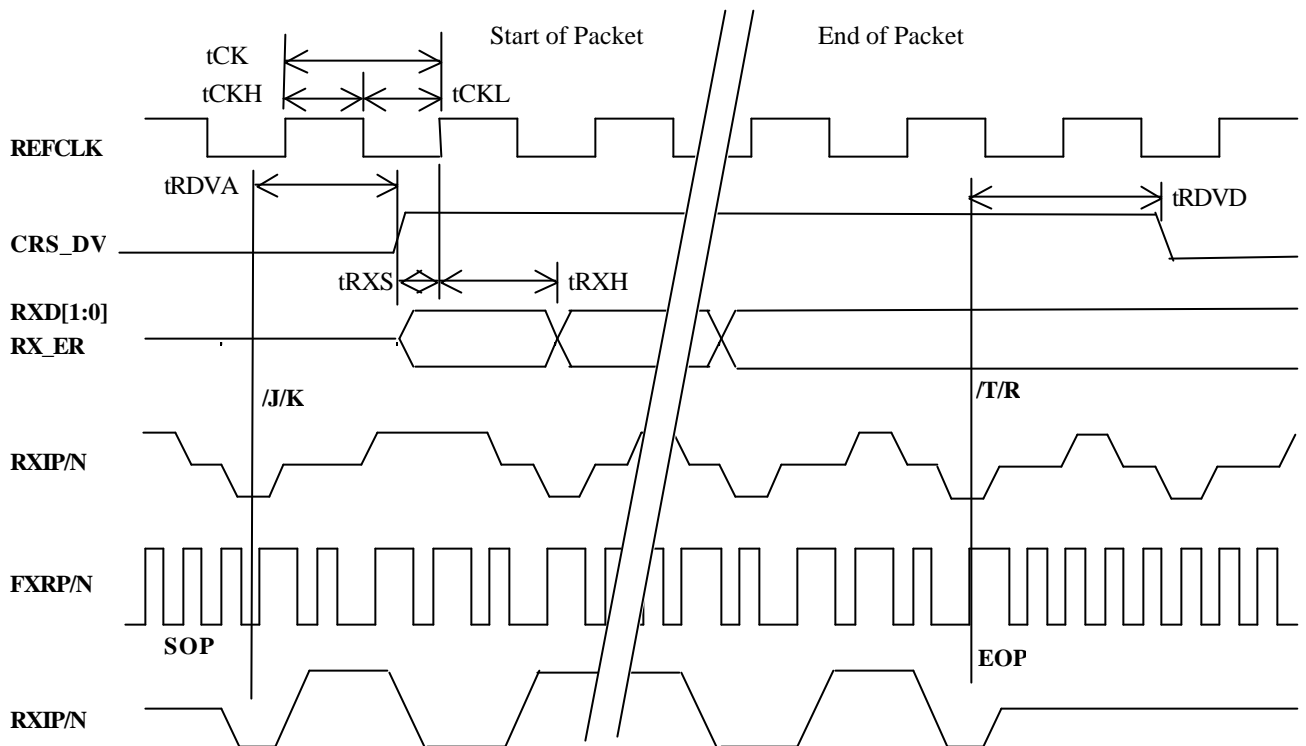

100Base-TX/FX & 10Base-T RMII Receive Timing

AC104QF

Ultra Low Power 10/100 Quad RMII Ethernet Transceiver

TX APPLICATION TERMINATION

Please contact Altima Communications Inc. for the latest component value recommendation

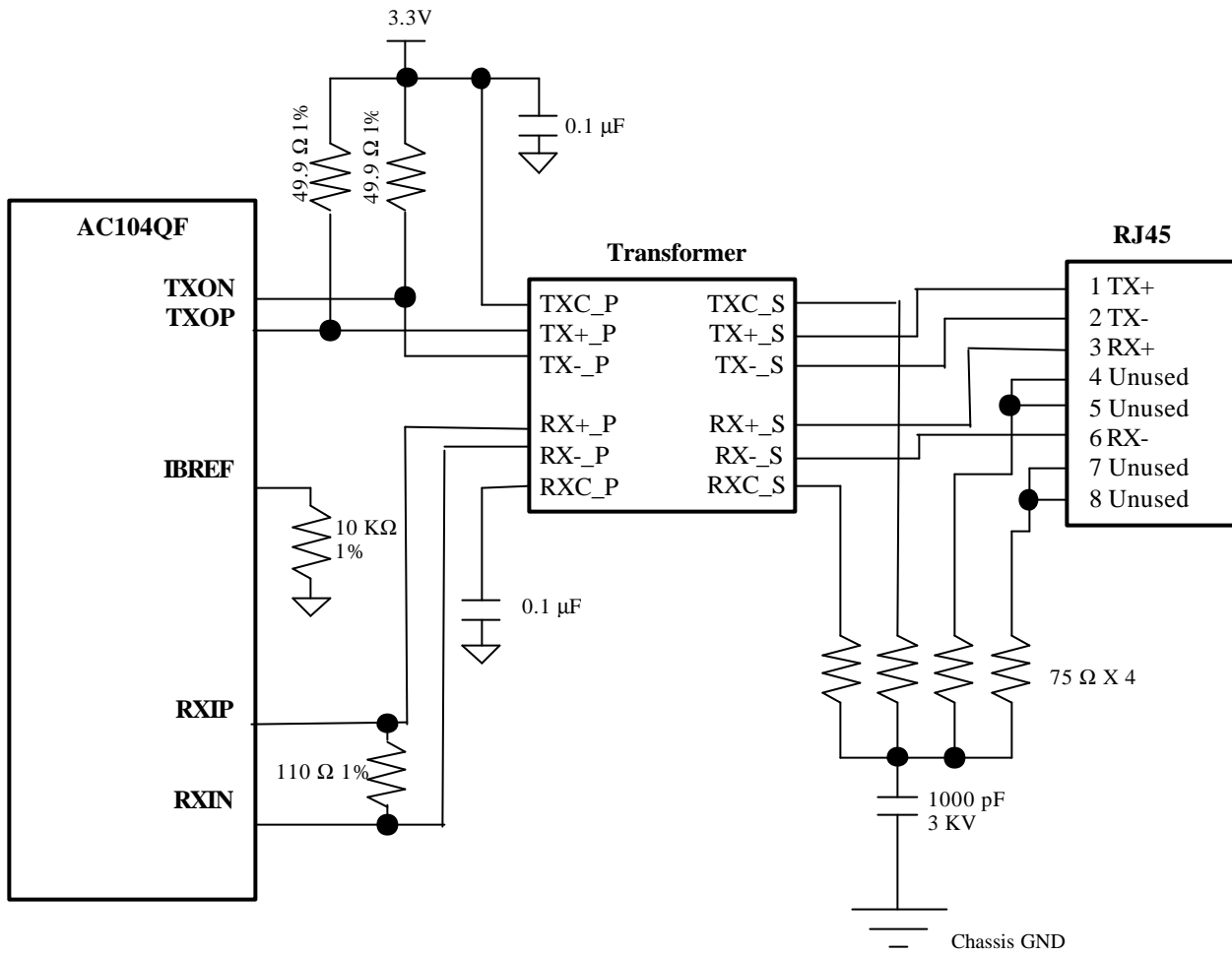

AC104QF

Ultra Low Power 10/100 Quad RMII Ethernet Transceiver

FX APPLICATION TERMINATION

Please contact Altima Communications Inc. for the latest component value recommendation

To enable the FX mode, FX_DIS pin must be pulled low by a 1 K Ω resistor.

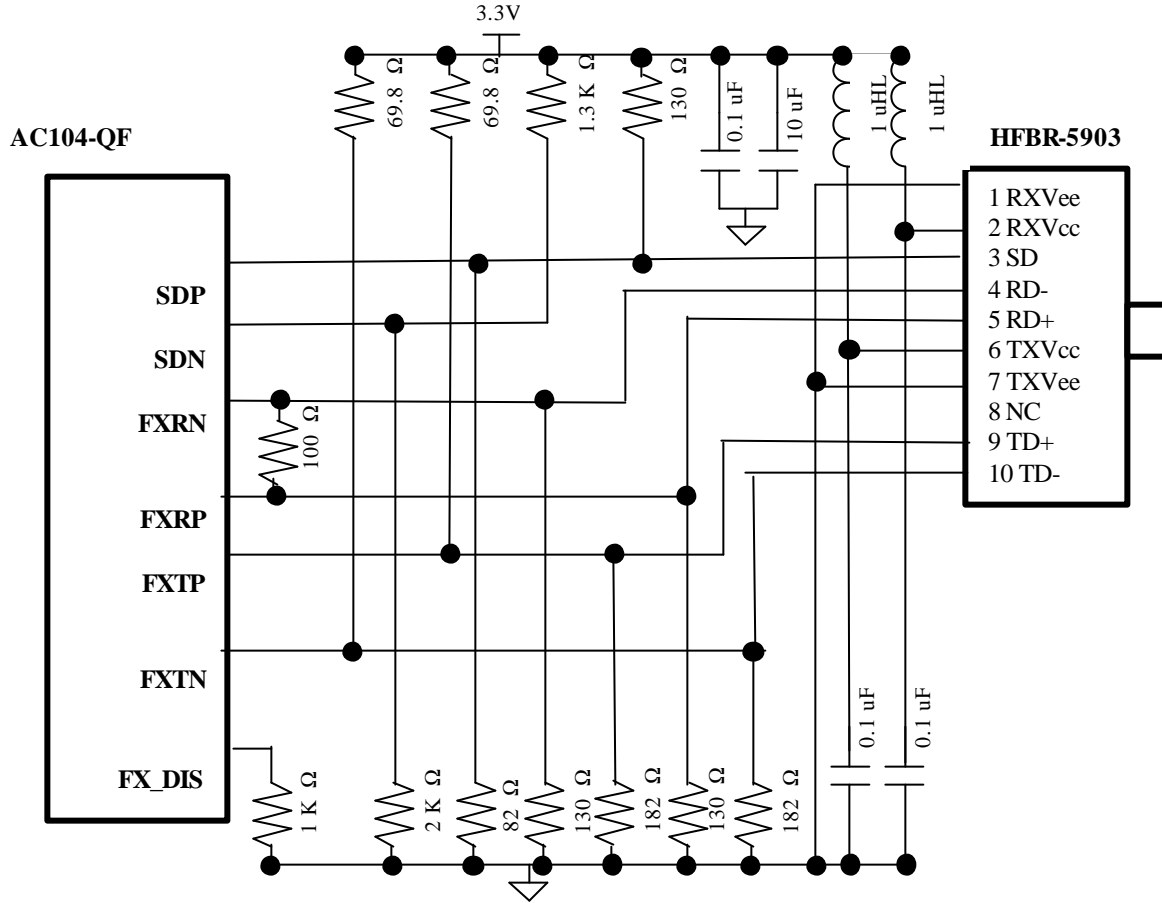

AC104QF

Ultra Low Power 10/100 Quad RMII Ethernet Transceiver

POWER AND GROUND FILTERING FOR AC104QF

Please contact Altima Communications Inc. for the latest component value recommendation.

- Ground
- Power
- |— .1uf Cap

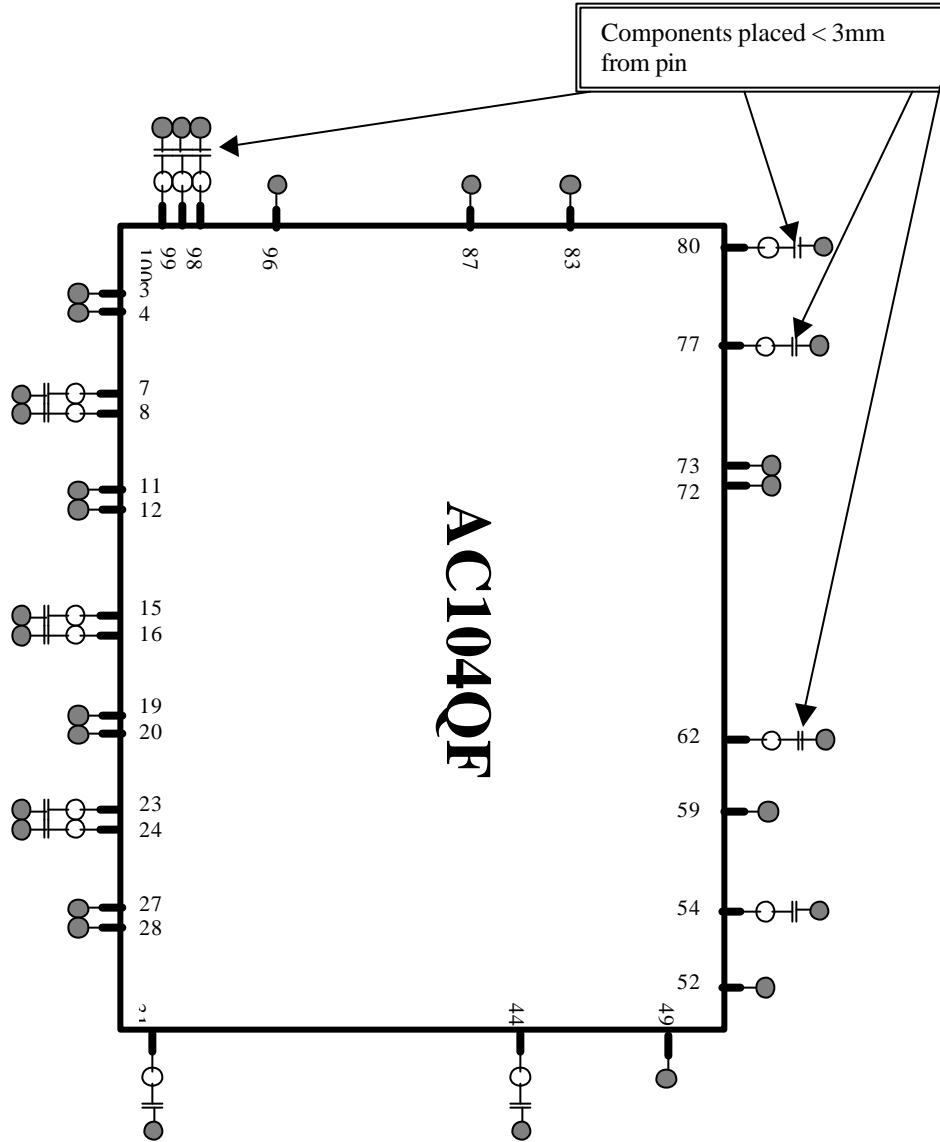

AC104QF
Ultra Low Power 10/100 Quad RMII Ethernet Transceiver

PACKAGE DIMENSIONS FOR AC104QF (100 PIN PQFP)

Quad Flat Pack Outline (20 x 14 mm)

N	A	A1	A2	B	D	D1	E	E1	e	L	L1
100	3.40 Max	0.25 Min	2.70 ± 0.2	0.3 ± 0.1	23.20 ± 0.25	20.00 ± 0.10	17.20 ± 0.25	14.00 ± 0.10	0.65	0.88 ± 0.2	1.60 ± 0.12

