



### Product Features

- 50 – 870 MHz
- 13 dB Gain
- 3 dB Noise Figure
- >+36 dBm OIP3
- +20 dBm P1dB
- Single +5 Bias Supply
- Internally matched to 50 Ω
- Lead-free/Green/RoHS-compliant SOT-89 Package
- MTTF > 1000 years

### Applications

- Mobile Infrastructure
- CATV / DBS
- Defense / Homeland Security
- NMT-450 Infrastructure

### Specifications <sup>(1)</sup>

Parameter	Units	Min	Typ	Max	Comment
Operational Bandwidth	MHz	50		870	
Test Frequency	MHz		800		
Gain	dB	12	12.9	14	
Input Return Loss	dB		10		See note 2
Output Return Loss	dB		20		
Output P1dB	dBm		+20		
Output IP3	dBm	+33	>+36		Pout = +5 dBm/tone, 10 MHz spacing.
Noise Figure	dB		2.9		See note 2
Operating Current Range	mA	120	150	180	
Supply Voltage	V		+5		

1. Test conditions unless otherwise noted: T = 25° C, 50 Ω system.  
 2. S11 and Noise Figure can be improved using an optional input matching network (typically just a series inductor).

### Product Description

The AG103 is a general-purpose gain block that offers good dynamic range and low noise figure in a low-cost surface-mount package. The combination of high OIP3 and tight gain variation window makes it attractive for a multitude of applications. The device combines dependable performance with superb quality to maintain MTTF values exceeding 1000 years at mounting temperatures of +85°C and is available in both the standard SOT-89 package and the environmentally-friendly lead-free/green/RoHS-compliant and green SOT-89 package. All devices are 100% RF & DC tested.

The AG103 uses a high reliability GaAs MMIC technology and only requires DC-blocking and bypass capacitors, and an inductive RF choke for operation. Internal matching provides a 50 ohm input / output impedance minimizing the number of required external components.

The AG103 GaAs MMIC amplifier is well suited for wireless infrastructure such as NMT-450, homeland security, and 2<sup>nd</sup> generation mobile infrastructure utilizing the cellular band. In addition, the amplifier can be used for applications in various IF frequency bands.

### Functional Diagram

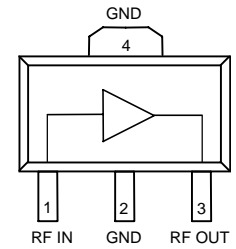

Function	Pin No.
Input	1
Output/Bias	3
Ground	2, 4

### Absolute Maximum Rating

Parameter	Rating
Operating Case Temperature	-40 to +85 °C
Storage Temperature	-55 to +150 °C
DC Voltage	+6 V
RF Input Power (continuous)	+10 dBm
Junction Temperature	+220° C

Operation of this device above any of these parameters may cause permanent damage.

### Ordering Information

Part No.	Description
AG103	GaAs MMIC Gain Block (lead SOT-89 Pkg)
AG103-G	GaAs MMIC Gain Block (lead-free/green/RoHS-compliant SOT-89 Pkg)
AG103-PCB	200 – 600 MHz Fully Assembled Application Circuit

Specifications and information are subject to change without notice.



### Typical Device Data

S-Parameters ( $V_{DS} = +5\text{ V}$ ,  $I_{DS} = 150\text{ mA}$ ,  $T = 25^\circ\text{C}$ , unmatched 50 ohm system)

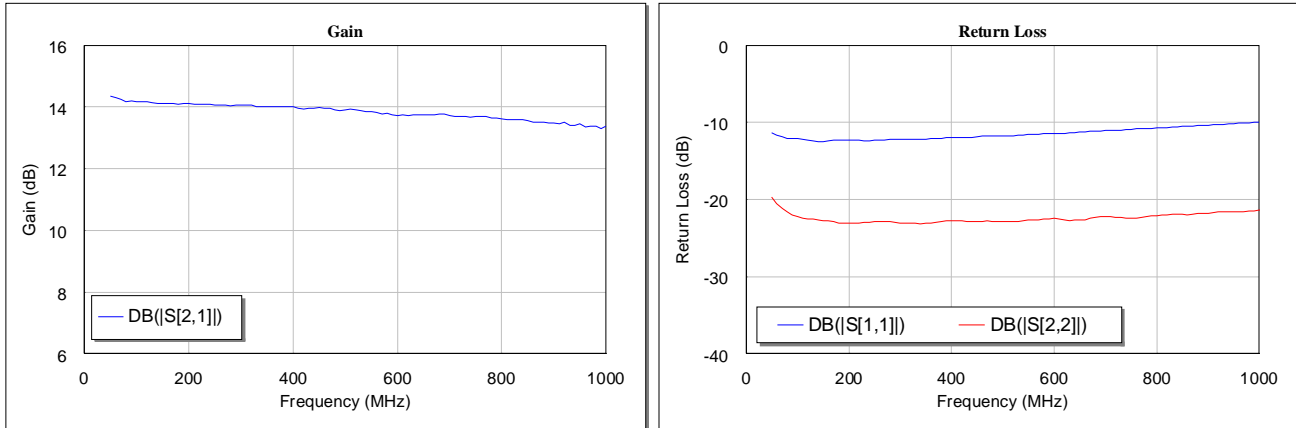

The device can be used as a gain block with no input or output matching. For optimal input return loss and noise figure performance, the amplifier can be slightly tuned for the frequency of operation as shown in the reference designs in this datasheet.

S-Parameters ( $V_{DS} = +5\text{ V}$ ,  $I_{DS} = 150\text{ mA}$ ,  $T = 25^\circ\text{C}$ , calibrated to device leads)

Freq (MHz)	S11 (dB)	S11 (ang)	S21 (dB)	S21 (ang)	S12 (dB)	S12 (ang)	S22 (dB)	S22 (ang)
50	-11.30	-30.04	14.35	170.13	-20.20	8.20	-19.64	-120.38
100	-12.11	-24.59	14.17	171.02	-20.12	3.18	-22.19	-142.79
150	-12.46	-25.65	14.13	169.71	-20.08	1.39	-22.73	-155.71
200	-12.29	-29.97	14.10	167.82	-20.05	-0.31	-23.12	-160.90
250	-12.35	-32.81	14.07	165.49	-19.99	-1.51	-22.90	-166.97
300	-12.16	-38.15	14.06	163.30	-19.99	-2.59	-23.03	-167.62
350	-12.14	-42.37	14.02	160.54	-20.01	-3.37	-23.03	-172.30
400	-11.95	-47.75	14.01	158.38	-19.99	-4.74	-22.80	-173.68
450	-11.88	-52.03	13.98	155.78	-20.01	-5.79	-22.87	-176.13
500	-11.73	-57.01	13.91	153.04	-19.97	-6.12	-22.90	-176.83
550	-11.60	-61.03	13.85	150.70	-19.95	-7.43	-22.68	-179.96
600	-11.48	-66.17	13.73	148.73	-20.00	-8.03	-22.48	-178.91
650	-11.26	-70.02	13.76	146.23	-20.03	-9.00	-22.64	-177.09
700	-11.08	-74.52	13.72	144.01	-20.01	-9.46	-22.19	-176.83
750	-10.90	-79.00	13.68	141.28	-19.93	-10.57	-22.38	-175.26
800	-10.73	-83.40	13.62	138.73	-19.95	-11.34	-22.12	-173.64
850	-10.51	-87.42	13.57	136.01	-19.94	-12.38	-21.94	-172.78
900	-10.34	-91.85	13.47	133.71	-19.96	-12.95	-21.78	-171.76



## Application Circuit: 200 – 600 MHz (AG103-PCB)

### Typical Performance

Frequency	450 MHz
S21 - Gain	13.5 dB
S11	-23 dB
S22	-14 dB
Output P1dB	+21 dBm
Output IP3	+36 dBm
Noise Figure	2.7 dB
Bias	+5 V @ 150 mA

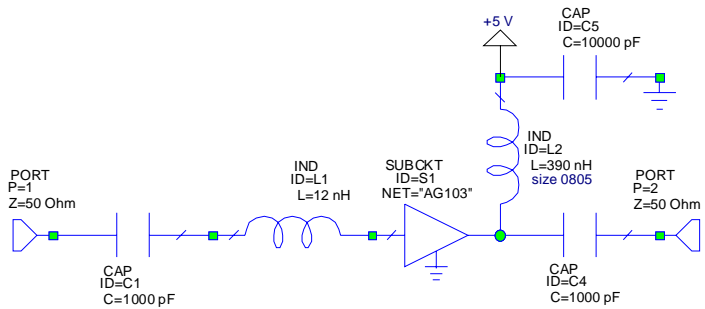
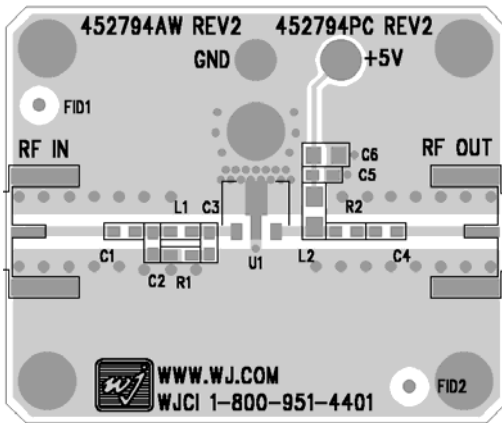
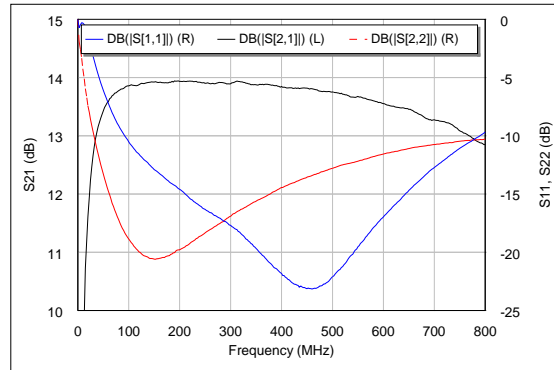

#### Notes:

1. The amplifier should be connected directly to a +5 V regulator; no dropping resistor is required.
2. If no DC signal is present at the input, C1 can be removed. The input is internally grounded in the amplifier.
3. C2, C3, C5, & R1 are not used in the circuit. R2 is shorted across with 0  $\Omega$  in the circuit. These placeholders shown in the silkscreen are for applications with other devices.

Circuit Board Material: .014" FR-4, 4 layers, .062" total thickness

## Reference Design: 70 MHz

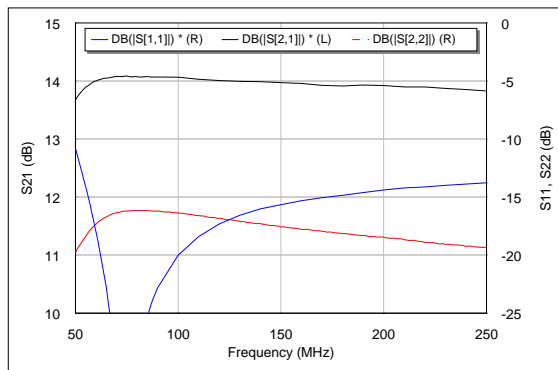
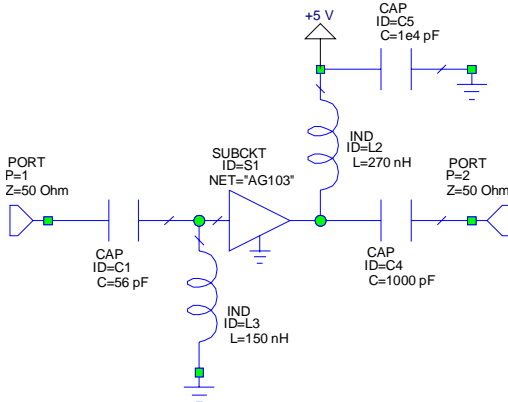

## Reference Design: 900 MHz

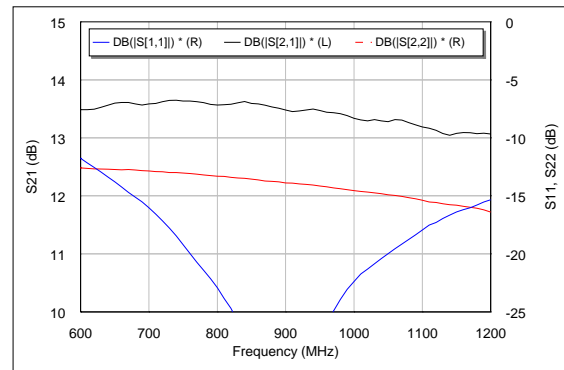
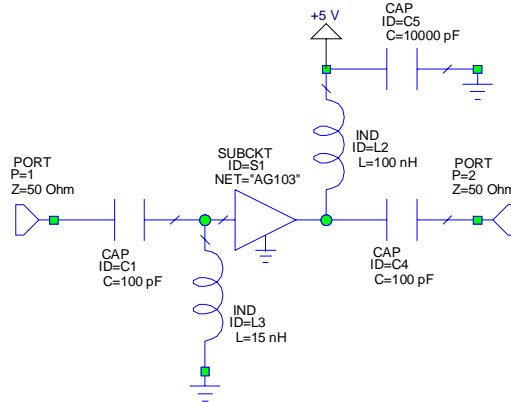

Specifications and information are subject to change without notice.



## AG103 (SOT-89 Package) Mechanical Information

This package may contain lead-bearing materials. The plating material on the leads is SnPb.

### Outline Drawing

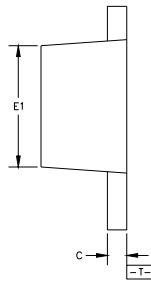
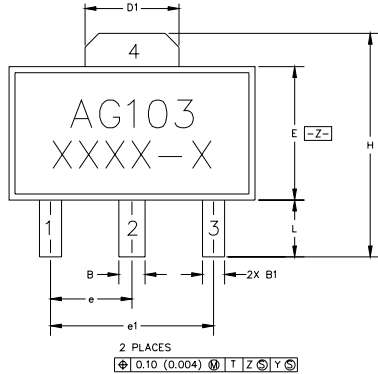

SYMBOL	MIN	MAX
A	1.40 (.055)	1.60 (.063)
B	.44 (.017)	.56 (.022)
B1	.36 (.014)	.48 (.019)
C	.35 (.014)	.44 (.017)
D	4.40 (.173)	4.60 (.181)
D1	1.62 (.064)	1.83 (.072)
E	2.29 (.090)	2.60 (.102)
E1	2.01 (.079)	2.29 (.090)
e	1.50 (.059)	BSC
e1	3.00 (.118)	BSC
H	3.94 (.155)	4.25 (.167)
L	.89 (.035)	1.20 (.047)
M	4.04 (.159)	4.19 (.165)

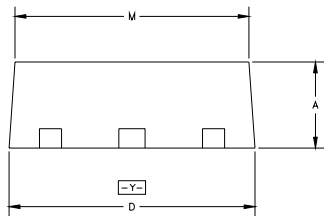

- NOTES:
1. DIMENSIONS CONFORM WITH JEDEC TO-243C EXCEPT WHERE INDICATED.
  2. DIMENSIONS ARE EXPRESSED IN MILLIMETERS(INCHES).
  3. DIMENSIONING AND TOLERANCING IAW ANSI Y14.5M

### Land Pattern

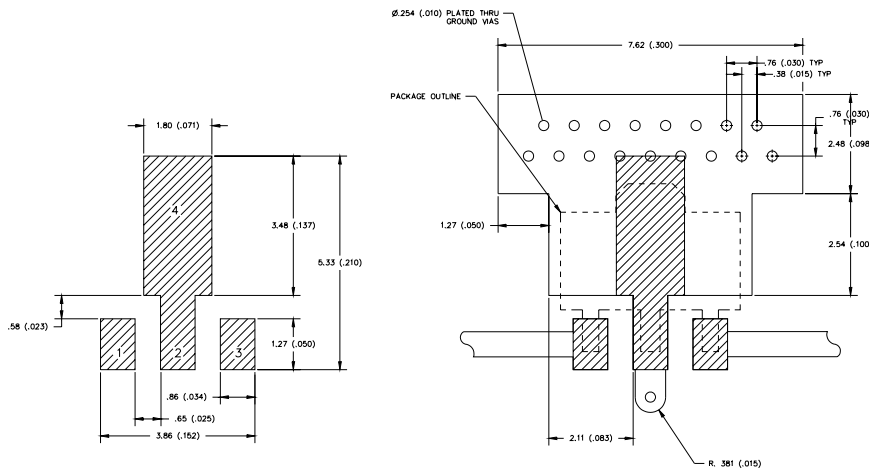

### Thermal Specifications

Parameter	Rating
Operating Case Temperature	-40 to +85°C
Thermal Resistance, Rth <sup>(1)</sup>	59° C / W
Junction Temperature, Tjc <sup>(2)</sup>	129° C

1. The thermal resistance is referenced from the hottest part of the junction to the ground tab.
2. This corresponds to the typical biasing condition of +5V, 150 mA at an 85°C case temperature. A minimum MTTF of 1 million hours is achieved for junction temperatures below 160 °C.

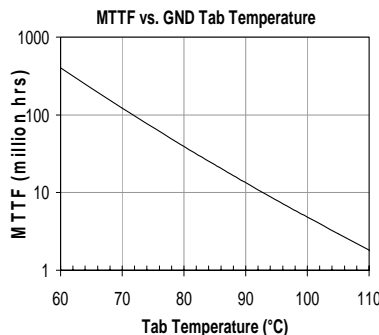

### Product Marking

The AG103 will be marked with an “AG103” designator. An alphanumeric lot code (“XXXX-X”) is also marked below the part designator on the top surface of the package.

Tape and reel specifications for this part are located on the website in the “Application Notes” section.

### MSL / ESD Rating



Caution! ESD sensitive device.

ESD Rating: Class 1B  
 Value: Passes ≥ 500V to <1000V  
 Test: Human Body Model (HBM)  
 Standard: JEDEC Standard JESD22-A114

ESD Rating: Class IV  
 Value: Passes ≥ 1000V to <2000V  
 Test: Charged Device Model (CDM)  
 Standard: JEDEC Standard JESD22-C101

MSL Rating: Level 3 at +235° C convection reflow  
 Standard: JEDEC Standard J-STD-020

### Mounting Config. Notes

1. Ground / thermal vias are critical for the performance of this device. Vias should use a .35mm (#80 / .0135”) diameter drill and have a final plated thru diameter of .25 mm (.010”).
2. Add as much copper as possible to inner and outer layers near the part to ensure optimal thermal performance.
3. Mounting screws can be added near the part to fasten the board to a heatsink. Ensure that the ground / thermal via region contacts the heatsink.
4. Do not put solder mask on the backside of the PC board in the region where the board contacts the heatsink.
5. RF trace width depends upon the PC board material and construction.
6. Use 1 oz. Copper minimum.
7. All dimensions are in millimeters (inches). Angles are in degrees.

## AG103-G (Green / Lead-free SOT-89 Package) Mechanical Information

This package is lead-free/Green/RoHS-compliant. It is compatible with both lead-free (maximum 260°C reflow temperature) and leaded (maximum 245°C reflow temperature) soldering processes. The plating material on the leads is NiPdAu.

### Outline Drawing

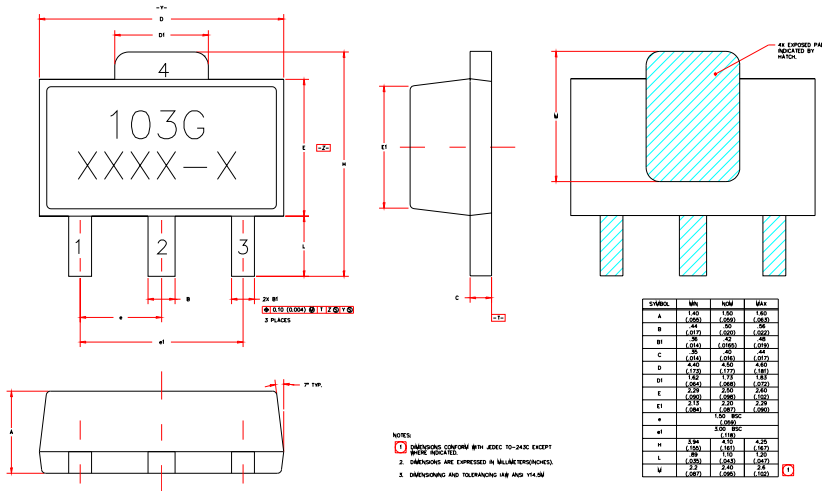

### Product Marking

The AG103-G will be marked with an "103G" designator. An alphanumeric lot code ("XXXX-X") is also marked below the part designator on the top surface of the package.

Tape and reel specifications for this part are located on the website in the "Application Notes" section.

### MSL / ESD Rating



Caution! ESD sensitive device.

ESD Rating: Class 1B  
 Value: Passes  $\geq 500V$  to  $<1000V$   
 Test: Human Body Model (HBM)  
 Standard: JEDEC Standard JESD22-A114

ESD Rating: Class IV  
 Value: Passes  $\geq 1000V$  to  $<2000V$   
 Test: Charged Device Model (CDM)  
 Standard: JEDEC Standard JESD22-C101

MSL Rating: Level 3 at  $+260^\circ C$  convection reflow  
 Standard: JEDEC Standard J-STD-020

### Land Pattern

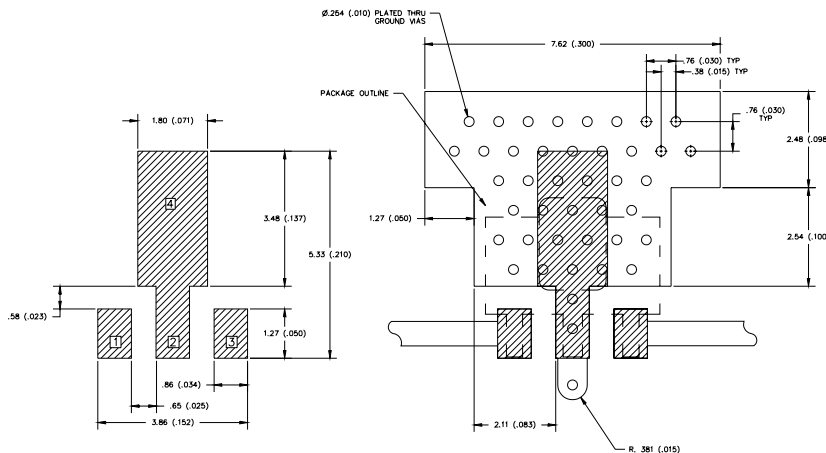

### Thermal Specifications

Parameter	Rating
Operating Case Temperature	-40 to +85°C
Thermal Resistance, $R_{th}^{(1)}$	59° C / W
Junction Temperature, $T_{jc}^{(2)}$	129° C

- The thermal resistance is referenced from the hottest part of the junction to the ground tab (pin 4).
- This corresponds to the typical biasing condition of +5V, 150 mA at an 85°C case temperature. A minimum MTTF of 1 million hours is achieved for junction temperatures below 160 °C.

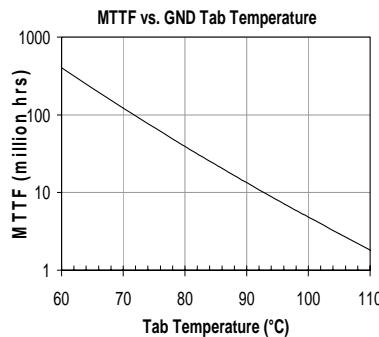

### Mounting Config. Notes

- Ground / thermal vias are critical for the proper performance of this device. Vias should use a .35mm (#80 / .0135") diameter drill and have a final plated thru diameter of .25 mm (.010").
- Add as much copper as possible to inner and outer layers near the part to ensure optimal thermal performance.
- Mounting screws can be added near the part to fasten the board to a heatsink. Ensure that the ground / thermal via region contacts the heatsink.
- Do not put solder mask on the backside of the PC board in the region where the board contacts the heatsink.
- RF trace width depends upon the PC board material and construction.
- Use 1 oz. Copper minimum.
- All dimensions are in millimeters (inches). Angles are in degrees.