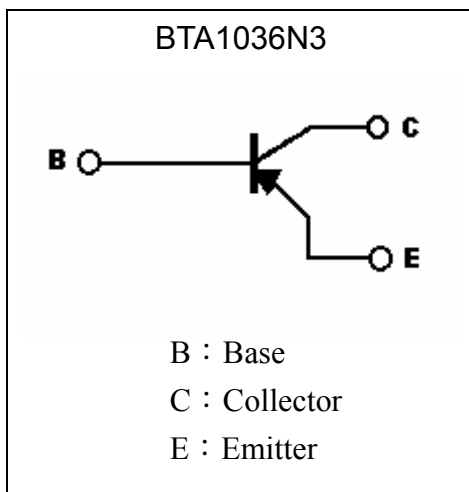
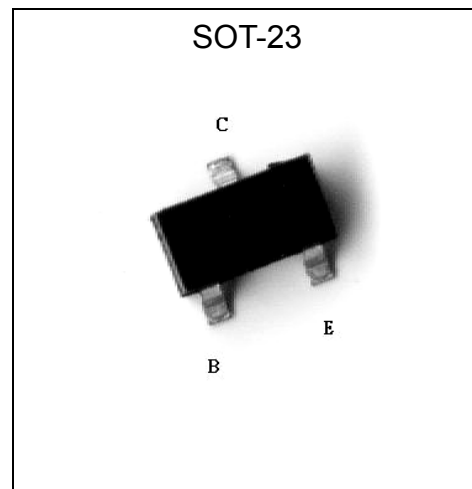

General Purpose PNP Epitaxial Planar Transistor

BTA1036N3

Description

- The BTA1036N3 is designed for using in driver stage of AF amplifier and general purpose amplification.
- Large I_C , $I_{C(Max)} = -0.6A$
- Low $V_{CE(sat)}$, ideal for low-voltage operation.
- Complementary to BTC2411N3.
- Pb-free package

Symbol

Outline

Absolute Maximum Ratings ($T_a = 25^\circ C$)

Parameter	Symbol	Limits	Unit
Collector-Base Voltage	V_{CBO}	-60	V
Collector-Emitter Voltage	V_{CEO}	-60	V
Emitter-Base Voltage	V_{EBO}	-5	V
Collector Current	I_C	-0.6	A
Power Dissipation	P_d	225	mW
Thermal Resistance, Junction to Ambient	$R_{\theta JA}$	556	$^\circ C/W$
Junction Temperature	T_j	150	$^\circ C$
Storage Temperature	T_{stg}	-55~+150	$^\circ C$

**Characteristics (Ta=25°C)**

Symbol	Min.	Typ.	Max.	Unit	Test Conditions
BVCBO	-60	-	-	V	IC=-10μA
BVCEO	-60	-	-	V	IC=-10mA
BVEBO	-5	-	-	V	IE=-10μA
ICBO	-	-	-10	nA	VCB=-50V
ICEX	-	-	-50	nA	VCE=-30V, VEB=-0.5V
*VCE(sat) 1	-	-	-0.4	V	IC=-150mA, IB=-15mA
*VCE(sat) 2	-	-	-0.75	V	IC=-500mA, IB=-50mA
*VBE(sat) 1	-	-	-0.95	V	IC=-150mA, IB=-15mA
*VBE(sat) 2	-	-	-1.3	V	IC=-500mA, IB=-50mA
hFE 1	75	-	-	-	VCE=-10V, IC=-0.1mA
hFE 2	100	-	-	-	VCE=-10V, IC=-1mA
hFE 3	100	-	-	-	VCE=-10V, IC=-10mA
*hFE 4	82	-	390	-	VCE=-10V, IC=-150mA
*hFE 5	50	-	-	-	VCE=-10V, IC=-500mA
fT	200	-	-	MHz	VCE=-5V, IC=-50mA, f=100MHz
Cob	-	-	8	pF	VCB=-10V, f=1MHz

*Pulse Test: Pulse Width ≤380μs, Duty Cycle≤2%

Classification Of hFE 4

Rank	P	Q	R
Range	82~180	120~270	180~390



Characteristic Curves

Current Gain vs Collector Current

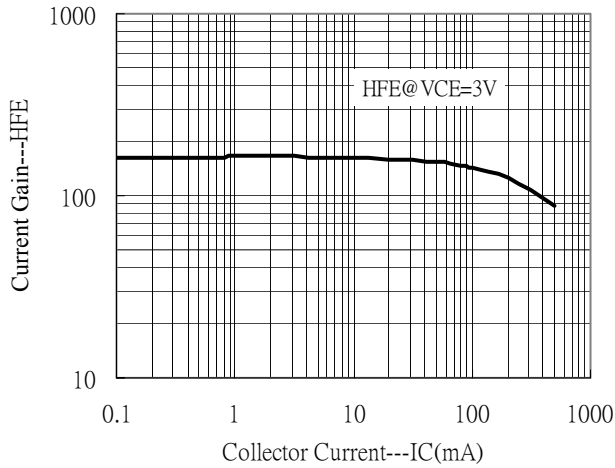

Saturation Voltage vs Collector Current

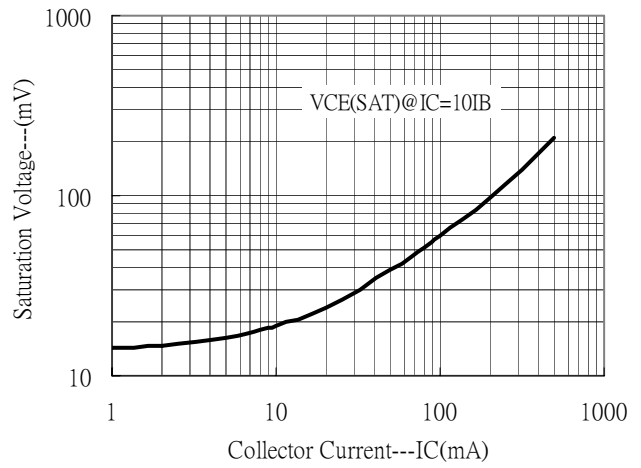

Saturation Voltage vs Collector Current

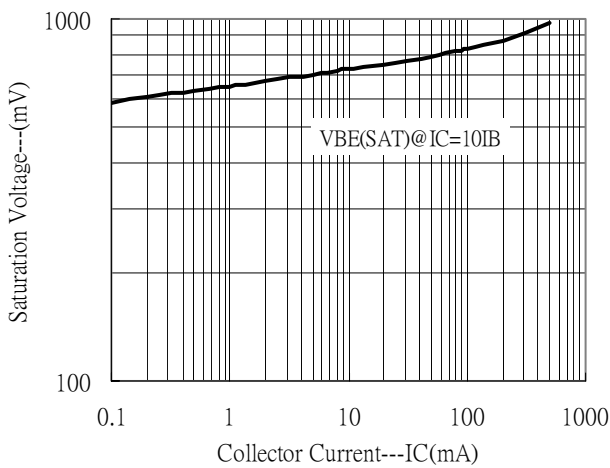

Cutoff Frequency vs Collector Current

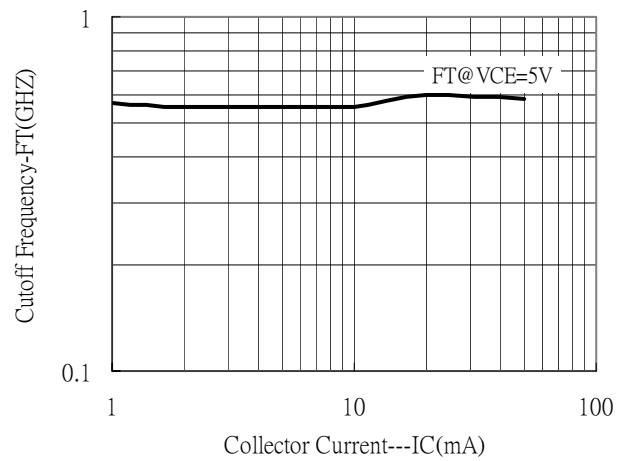

Power Derating Curve

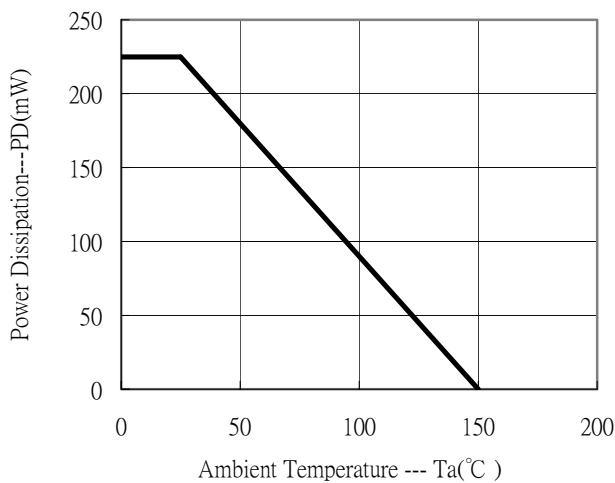

Reel Dimension

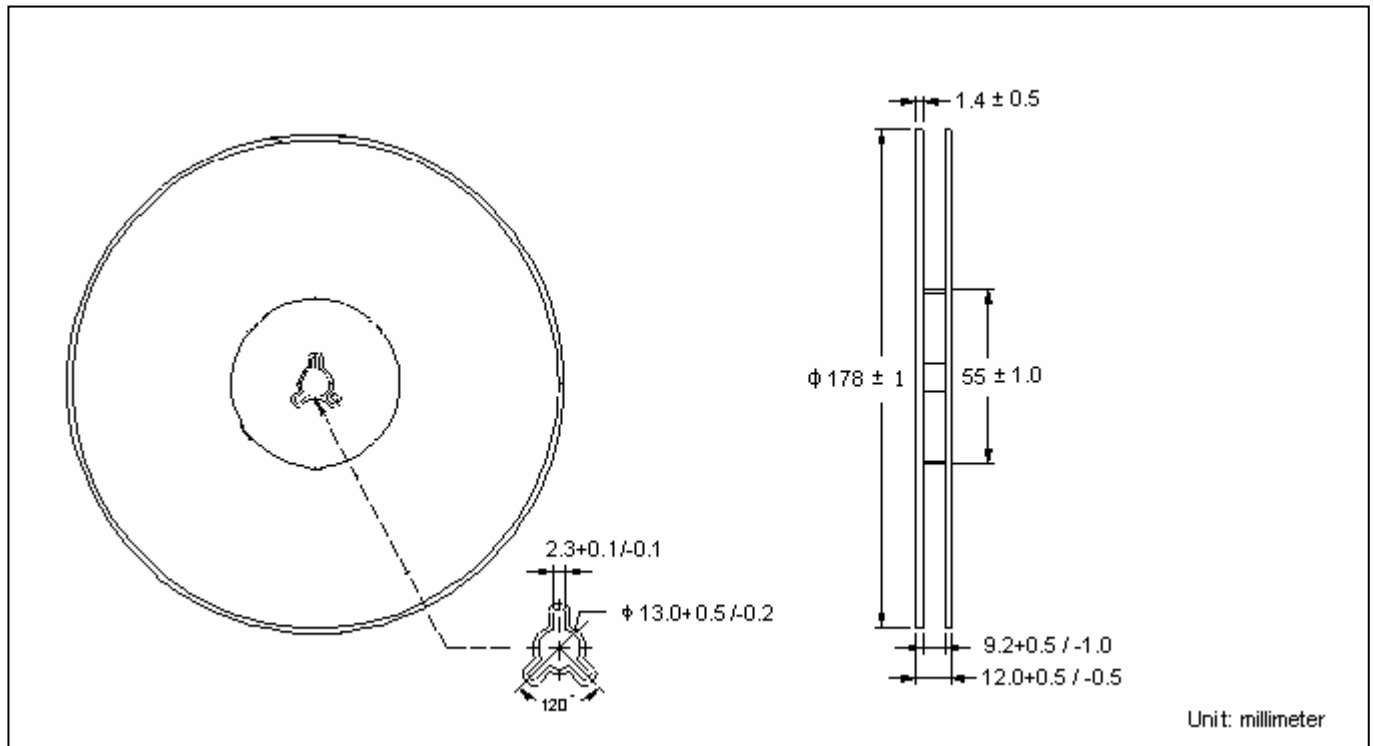

Carrier Tape Dimension

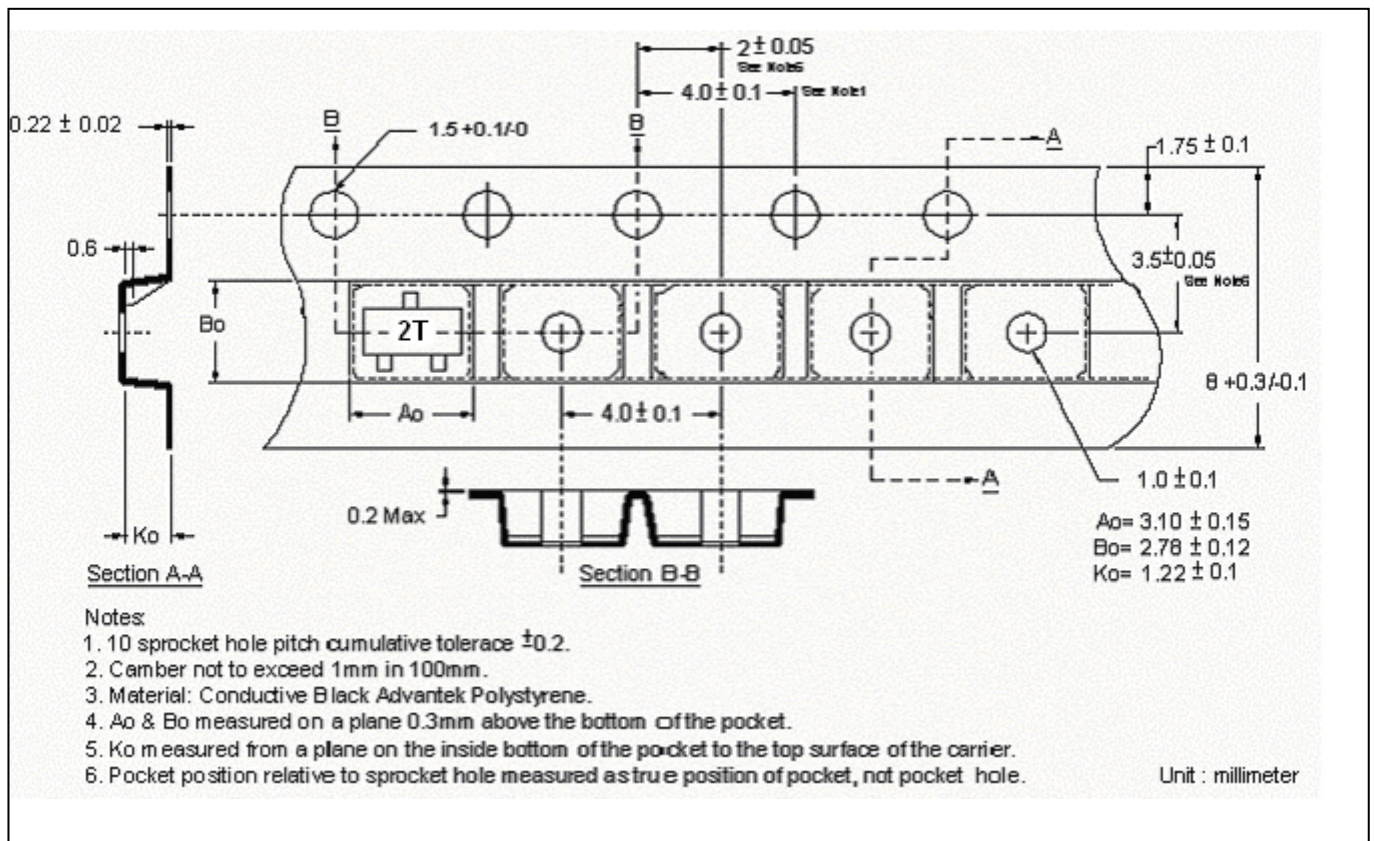

SOT-23 Dimension

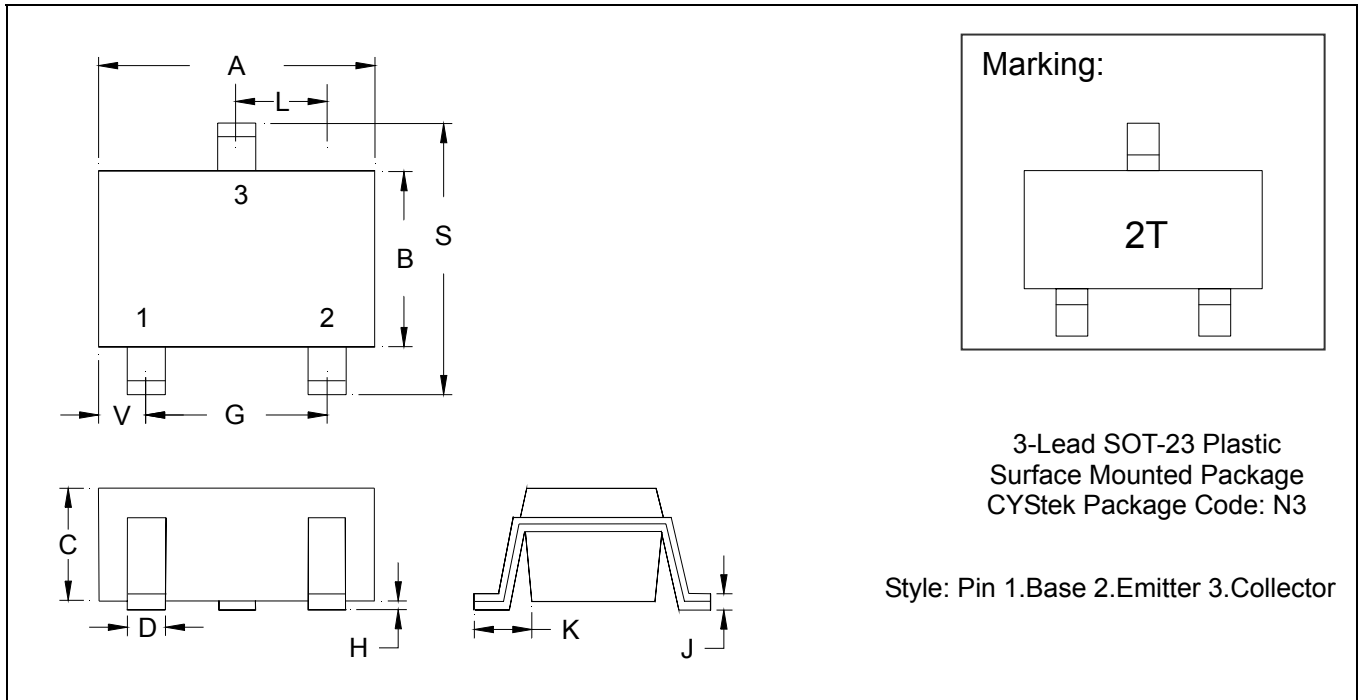

*: Typical

DIM	Inches		Millimeters		DIM	Inches		Millimeters	
	Min.	Max.	Min.	Max.		Min.	Max.	Min.	Max.
A	0.1102	0.1204	2.80	3.04	J	0.0034	0.0070	0.085	0.177
B	0.0472	0.0630	1.20	1.60	K	0.0128	0.0266	0.32	0.67
C	0.0335	0.0512	0.89	1.30	L	0.0335	0.0453	0.85	1.15
D	0.0118	0.0197	0.30	0.50	S	0.0830	0.1083	2.10	2.75
G	0.0669	0.0910	1.70	2.30	V	0.0098	0.0256	0.25	0.65
H	0.0005	0.0040	0.013	0.10					

Notes: 1.Controlling dimension: millimeters.
 2.Maximum lead thickness includes lead finish thickness, and minimum lead thickness is the minimum thickness of base material.
 3.If there is any question with packing specification or packing method, please contact your local CYStek sales office.

Material:

- Lead: 42 Alloy ; solder plating
- Mold Compound: Epoxy resin family, flammability solid burning class: UL94V-0

Important Notice:

- All rights are reserved. Reproduction in whole or in part is prohibited without the prior written approval of CYStek.
- CYStek reserves the right to make changes to its products without notice.
- CYStek **semiconductor products are not warranted to be suitable for use in Life-Support Applications, or systems.**
- CYStek assumes no liability for any consequence of customer product design, infringement of patents, or application assistance.