

High Voltage NPN Epitaxial Planar Transistor

BTN6517A3

Features

- High Breakdown Voltage: $BV_{CEO} \geq 350V$
- Complementary to BTP6520A3

Symbol

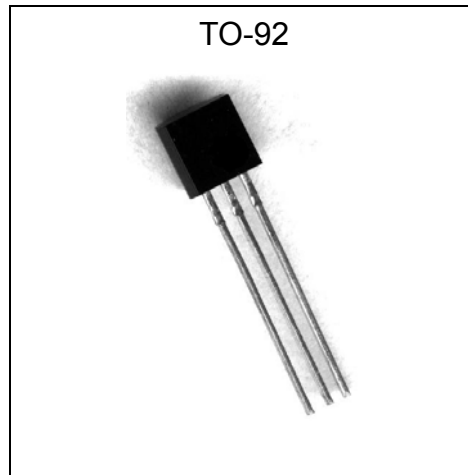
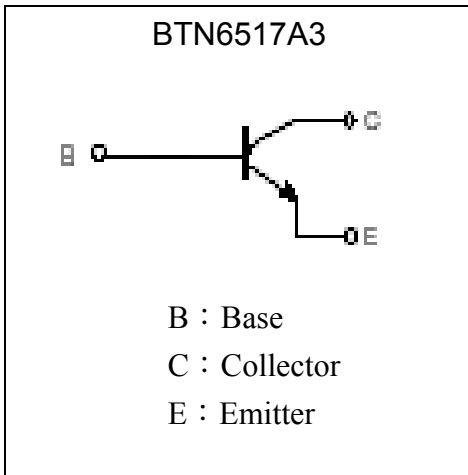

Absolute Maximum Ratings ($T_a=25^\circ C$)

Parameter	Symbol	Limits	Unit
Collector-Base Voltage	V_{CBO}	350	V
Collector-Emitter Voltage	V_{CEO}	350	V
Emitter-Base Voltage	V_{EBO}	6	V
Collector Current---continuous	I_C	500	mA
Power Dissipation @ $T_A=25^\circ C$	P_d	625	mW
Junction Temperature	T_j	150	$^\circ C$
Storage Temperature	T_{stg}	-55~+150	$^\circ C$



Characteristics (Ta=25°C)

Symbol	Min.	Typ.	Max.	Unit	Test Conditions
BVCBO	350	-	-	V	IC=100 μ A
BVCEO	350	-	-	V	IC=1mA
BVEBO	6	-	-	V	IE=10 μ A
ICBO	-	-	50	nA	VCB=250V
IEBO	-	-	50	nA	VEB=5V
VCE(sat) 1	-	-	0.3	V	IC=10mA, IB=1mA
VCE(sat) 2	-	-	0.35	V	IC=20mA, IB=2mA
*VCE(sat) 3	-	-	0.5	V	IC=30mA, IB=3mA
*VCE(sat) 4	-	-	1.0	V	IC=50mA, IB=5mA
VBE(sat) 1	-	-	0.75	V	IC=10mA, IB=1mA
VBE(sat) 2	-	-	0.85	V	IC=20mA, IB=2mA
*VBE(sat) 3	-	-	0.9	V	IC=30mA, IB=3mA
VBE(on)	-	-	2	V	VCE=10V, IC=100mA
hFE 1	20	-	-	-	VCE=10V, IC=1mA
hFE 2	30	-	-	-	VCE=10V, IC=10mA
*hFE 3	30	-	200	-	VCE=10V, IC=30mA
*hFE 4	20	-	200	-	VCE=10V, IC=50mA
*hFE 5	15	-	-	-	VCE=10V, IC=100mA
fT	40	-	200	MHz	VCE=20V, IC=10mA, f=20MHz
Cob	-	-	6	pF	VCB=20V, IE=0A, f=1MHz

*Pulse Test: Pulse Width \leq 380us, Duty Cycle \leq 2%



Characteristic Curves

Current Gain vs Collector Current

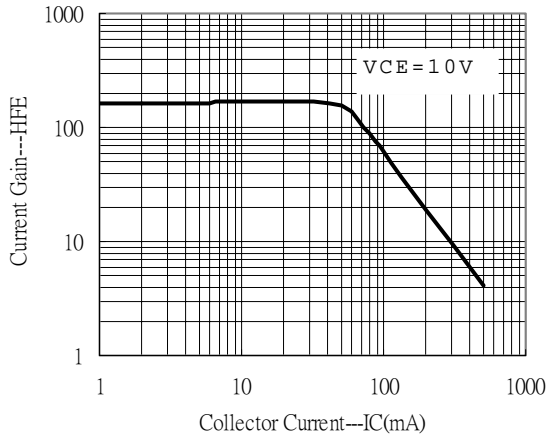

Saturation Voltage vs Collector Current

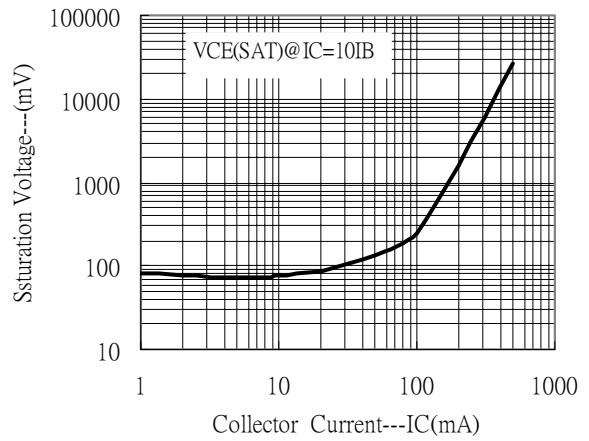

Saturation Voltage vs Collector Current

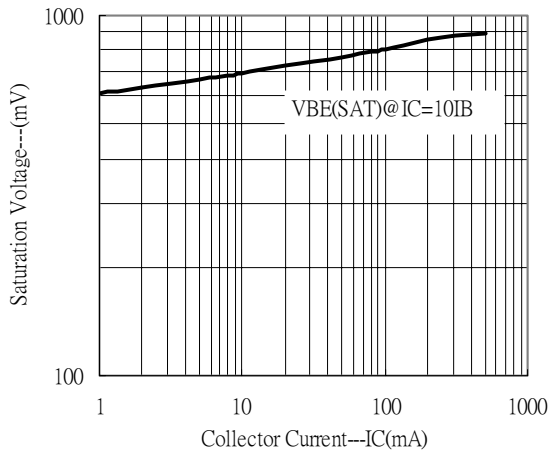

Power Derating Curve

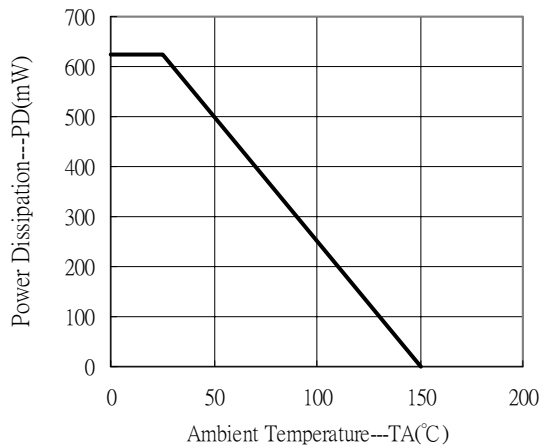

TO-92 Dimension

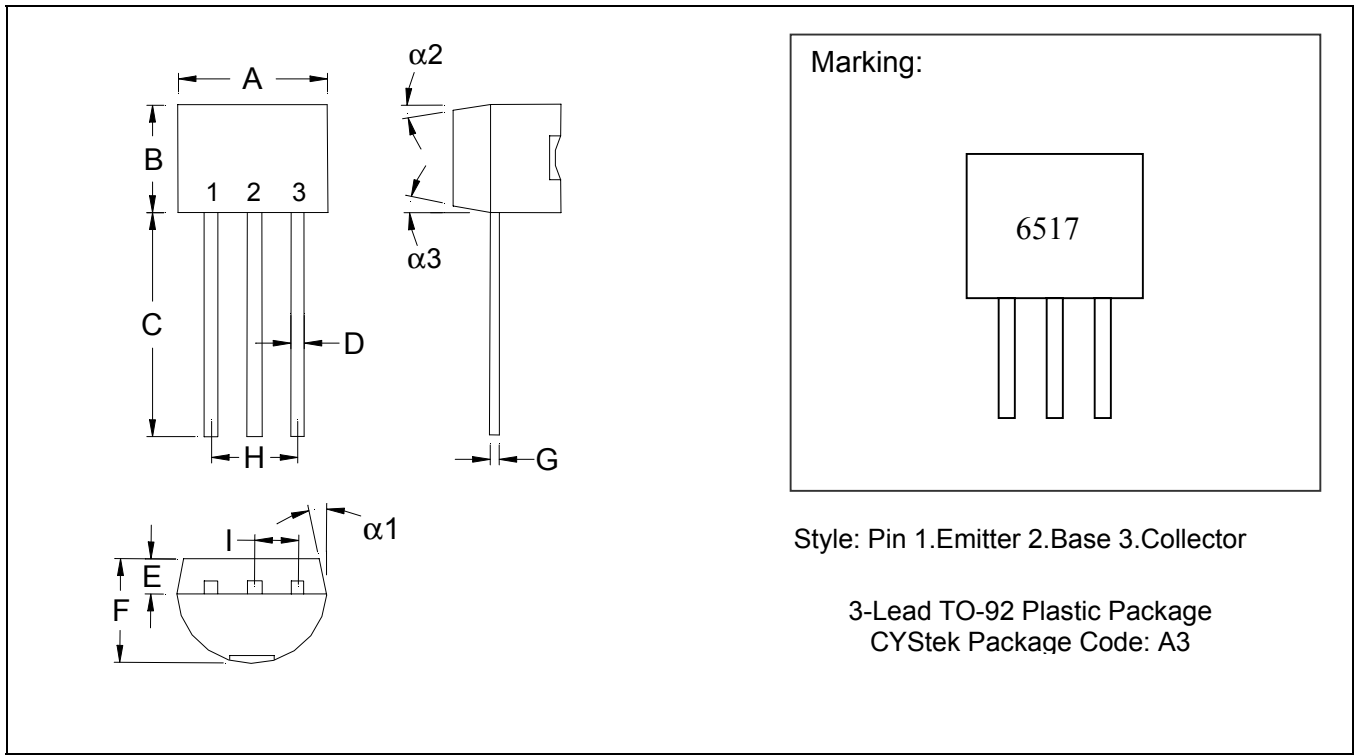

*: Typical

DIM	Inches		Millimeters		DIM	Inches		Millimeters	
	Min.	Max.	Min.	Max.		Min.	Max.	Min.	Max.
A	0.1704	0.1902	4.33	4.83	G	0.0142	0.0220	0.36	0.56
B	0.1704	0.1902	4.33	4.83	H	-	*0.1000	-	*2.54
C	0.5000	-	12.70	-	I	-	*0.0500	-	*1.27
D	0.0142	0.0220	0.36	0.56	$\alpha 1$	-	*5°	-	*5°
E	-	*0.0500	-	*1.27	$\alpha 2$	-	*2°	-	*2°
F	0.1323	0.1480	3.36	3.76	$\alpha 3$	-	*2°	-	*2°

- Notes: 1. Controlling dimension: millimeters.
 2. Maximum lead thickness includes lead finish thickness, and minimum lead thickness is the minimum thickness of base material.
 3. If there is any question with packing specification or packing method, please contact your local CYStek sales office.

Material:

- Lead: 42 Alloy ; solder plating
- Mold Compound: Epoxy resin family, flammability solid burning class: UL94V-0

Important Notice:

- All rights are reserved. Reproduction in whole or in part is prohibited without the prior written approval of CYStek.
- CYStek reserves the right to make changes to its products without notice.
- CYStek **semiconductor products are not warranted to be suitable for use in Life-Support Applications, or systems.**
- CYStek assumes no liability for any consequence of customer product design, infringement of patents, or application assistance.