

## HiRel C-Band GaAs Power-MESFET

- **HiRel Discrete and Microwave Semiconductor**
- For professional power amplifiers
- For frequencies from 100 MHz to 8 GHz
- Hermetically sealed microwave power package
- Low thermal resistance for high voltage application
- Power added efficiency > 55 %
-  **esa Space Qualification Expected 1998**  
ESA/SCC Detail Spec. No.: 5614/006,  
Type Variant No.s 04 to 06

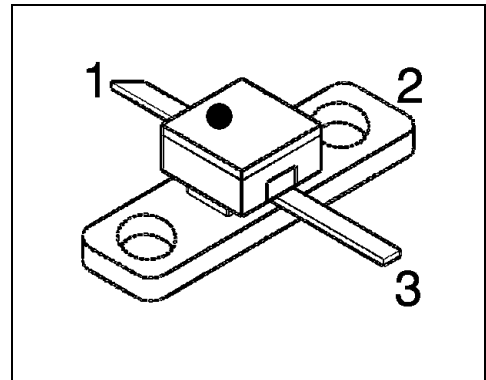

**ESD:** Electrostatic discharge sensitive device, observe handling precautions!

Type	Marking	Ordering Code	Pin Configuration			Package
			1	2	3	
CLY29-00 (ql)	-	see below	G	S	D	MWP-25
CLY29-05 (ql)						
CLY29-10 (ql)						

CLY29-nn: specifies output power level (see electrical characteristics)

(ql) Quality Level:	P: Professional Quality,	Ordering Code:	Q62702L117
	H: High Rel Quality,	Ordering Code:	on request
	S: Space Quality,	Ordering Code:	on request
	ES: ESA Space Quality,	Ordering Code:	Q62702L116

(see order instructions for ordering example)

## Maximum Ratings

Parameter	Symbol	Values	Unit
Drain-source voltage	$V_{DS}$	14	V
Drain-gate voltage	$V_{DG}$	16	V
Gate-source voltage	$V_{GS}$	- 6	V
Drain current	$I_D$	700	mA
Gate forward current	$I_G$	4	mA
Compression Level Operation Range 1 <sup>1)</sup>	$P_C$	1.5 at $V_{DS} \leq 9$ V 2.5 at $V_{DS} \leq 8$ V 3.5 at $V_{DS} \leq 7$ V	dB
Compression Level Operation Range 2 <sup>2)</sup>	$P_C$	3.5 at $V_{DS} \leq 7$ V	dB
Compression Level Operation Range 3 <sup>3)</sup>	$P_C$	tbd.	dB
Junction temperature	$T_J$	175	°C
Storage temperature range	$T_{stg}$	- 65...+ 175	°C
Total power dissipation <sup>4)</sup>	$P_{tot}$	3.55	W
Soldering temperature <sup>5)</sup>	$T_{sol}$	230	°C

## Thermal Resistance

Junction-soldering point	$R_{th,JS}$	≤ 38	K/W
--------------------------	-------------	------	-----

### Notes.:

- 1) Operation Range 1:  $135 \text{ mA} \leq I_D \leq 270 \text{ mA}$
- 2) Operation Range 2:  $I_D > 270 \text{ mA}$
- 3) Operation Range 3:  $I_D < 135 \text{ mA}$
- 4) At  $T_S = + 40 \text{ °C}$ . For  $T_S > + 40 \text{ °C}$  derating is required.
- 5) During 15 sec. maximum. The same terminal shall not be resoldered until 3 minutes have elapsed.

**Electrical Characteristics** (at  $T_A=25^\circ\text{C}$ ; unless otherwise specified)

Parameter	Symbol	Values			Unit
		min.	typ.	max.	
<b>DC Characteristics</b>					
Drain-source saturation current $V_{DS} = 2\text{ V}, V_{GS} = 0\text{ V}$	$I_{DSS}$	300	500	700	mA
Gate threshold voltage $V_{DS} = 3\text{ V}, I_D = 20\text{ mA}$	$-V_{Gth}$	1.6	2.6	3.6	V
Drain current at pinch-off, low $V_{DS}$ $V_{DS} = 3\text{ V}, V_{GS} = -3.8\text{ V}$	$I_{Dp3}$	-	-	50	$\mu\text{A}$
Gate current at pinch-off, low $V_{DS}$ $V_{DS} = 3\text{ V}, V_{GS} = -3.8\text{ V}$	$-I_{Gp3}$	-	-	20	$\mu\text{A}$
Drain current at pinch-off, high $V_{DS}$ $V_{DS} = 12\text{ V}, V_{GS} = -4\text{ V}$	$I_{Dp12}$	-	-	1000	$\mu\text{A}$
Gate current at pinch-off, high $V_{DS}$ $V_{DS} = 12\text{ V}, V_{GS} = -4\text{ V}$	$-I_{Gp12}$	-	-	400	$\mu\text{A}$
Transconductance $V_{DS} = 3\text{ V}, I_D = 200\text{ mA}$	$g_m$	150	190	-	mS
Thermal resistance junction to soldering point $V_{DS} = 9\text{ V}, I_D = 200\text{ mA}, T_s = +25^\circ\text{C}$	$R_{thJS}$	-	32	-	K/W

## Electrical Characteristics (continued)

Parameter	Symbol	Values			Unit
		min.	typ.	max.	
<b>AC Characteristics</b>					
Linear power gain <sup>1)</sup> $V_{DS} = 9\text{ V}$ , $I_D = 200\text{ mA}$ , $f = 2.3\text{ GHz}$ , $P_{in} = 0\text{ dBm}$	$G_{ip}$				dB
CLY29-00		13.5	15.0	-	
CLY29-05		14.0	15.2	-	
CLY29-10		14.0	15.2	-	
Output power at 1dB gain compr. <sup>1)</sup> $V_{DS} = 9\text{ V}$ , $I_{D(RF\ off)} = 200\text{ mA}$ , $f = 2.3\text{ GHz}$	$P_{1dB}$				dBm
CLY29-00		-	28.8	-	
CLY29-05		-	29.3	-	
CLY29-10		-	30.0	-	
Output power <sup>1)</sup> $V_{DS} = 9\text{ V}$ , $I_{D(RF\ off)} = 200\text{ mA}$ , $f = 2.3\text{ GHz}$ , $P_{in} = 16.5\text{ dBm}$	$P_{out}$				dBm
CLY29-00		28.5	28.8	-	
CLY29-05		29.0	29.3	-	
CLY29-10		29.5	30.0	-	
Power added efficiency <sup>1), 2)</sup> $V_{DS} = 9\text{ V}$ , $I_{D(RF\ off)} = 200\text{ mA}$ , $f = 2.3\text{ GHz}$ , $P_{in} = 16.5\text{ dBm}$	PAE				%
CLY29-00		40	50	-	
CLY29-05		45	52	-	
CLY29-10		45	55	-	

**Notes.:**

1) RF Power characteristics given for power matching conditions

 2) Power added efficiency:  $PAE = (P_{RFout} - P_{RFin}) / P_{DC}$

Typical Common Source S-Parameters

V <sub>DS</sub> = 3 V, I <sub>D</sub> = 180 mA, Z <sub>o</sub> = 50 Ω											
f	S11	<S11	S21	<S21	S12	<S12	S22	<S22	k-Fact.	S <sub>21</sub> /S <sub>12</sub>	MAG
[GHz]	[magn]	[angle]	[magn]	[angle]	[magn]	[angle]	[magn]	[angle]	[magn]	[dB]	[dB]
0,5	0,870	-78	7,618	129	0,0396	50	0,227	-138	0,37	22,8	
0,6	0,847	-83	7,318	126	0,0412	47	0,237	-141	0,43	22,5	
0,7	0,824	-88	6,983	123	0,0429	44	0,249	-144	0,49	22,1	
0,8	0,805	-95	6,620	119	0,0447	41	0,262	-148	0,55	21,7	
0,9	0,791	-103	6,248	114	0,0468	37	0,277	-152	0,58	21,3	
1,0	0,787	-111	5,881	109	0,0493	34	0,293	-155	0,59	20,8	
1,1	0,783	-118	5,537	104	0,0512	31	0,307	-159	0,61	20,3	
1,2	0,778	-125	5,213	99	0,0529	28	0,319	-162	0,63	19,9	
1,3	0,774	-131	4,916	95	0,0541	26	0,330	-165	0,66	19,6	
1,4	0,771	-137	4,641	91	0,0552	24	0,340	-167	0,69	19,2	
1,5	0,768	-142	4,387	87	0,0562	22	0,348	-170	0,72	18,9	
1,6	0,766	-147	4,155	83	0,0570	20	0,356	-172	0,75	18,6	
1,7	0,764	-152	3,942	80	0,0578	18	0,363	-174	0,78	18,3	
1,8	0,763	-156	3,746	77	0,0584	17	0,370	-176	0,82	18,1	
1,9	0,761	-160	3,565	73	0,0587	15	0,376	-178	0,85	17,8	
2,0	0,760	-163	3,401	70	0,0593	14	0,382	-180	0,88	17,6	
2,1	0,759	-167	3,248	68	0,0597	12	0,388	179	0,91	17,4	
2,2	0,759	-170	3,106	65	0,0602	11	0,393	177	0,95	17,1	
2,3	0,758	-173	2,977	62	0,0606	10	0,398	176	0,98	16,9	
2,4	0,758	-176	2,858	59	0,0607	9	0,403	174	1,01	16,7	16,1
2,5	0,757	-179	2,747	57	0,0610	8	0,408	173	1,04	16,5	15,3
2,6	0,757	179	2,644	54	0,0615	7	0,412	172	1,07	16,3	14,7
2,7	0,757	176	2,548	52	0,0619	6	0,417	170	1,10	16,1	14,2
2,8	0,757	173	2,459	49	0,0624	6	0,421	169	1,13	16,0	13,8
2,9	0,756	171	2,374	47	0,0630	5	0,424	168	1,15	15,8	13,4
3,0	0,756	169	2,295	44	0,0634	4	0,427	167	1,18	15,6	13,0
3,1	0,756	166	2,223	42	0,0638	4	0,431	165	1,21	15,4	12,7
3,2	0,756	164	2,155	40	0,0643	3	0,435	164	1,23	15,3	12,3
3,3	0,756	162	2,091	37	0,0650	2	0,439	163	1,25	15,1	12,0
3,4	0,756	160	2,030	35	0,0655	2	0,442	162	1,28	14,9	11,8
3,5	0,756	158	1,973	33	0,0659	1	0,447	161	1,30	14,8	11,5
3,6	0,756	156	1,919	31	0,0666	1	0,451	160	1,32	14,6	11,2
3,7	0,756	154	1,866	28	0,0670	0	0,456	158	1,34	14,4	11,0
3,8	0,756	152	1,817	26	0,0673	-1	0,460	157	1,36	14,3	10,7
3,9	0,756	150	1,770	24	0,0680	-1	0,465	156	1,38	14,2	10,5
4,0	0,756	148	1,725	22	0,0685	-2	0,470	155	1,39	14,0	10,3
4,1	0,757	146	1,681	20	0,0689	-2	0,475	153	1,42	13,9	10,0
4,2	0,757	144	1,639	18	0,0691	-3	0,479	152	1,44	13,8	9,8
4,3	0,758	142	1,599	15	0,0696	-4	0,483	151	1,46	13,6	9,6
4,4	0,758	140	1,560	13	0,0702	-4	0,487	150	1,47	13,5	9,4
4,5	0,759	138	1,524	11	0,0703	-5	0,491	148	1,49	13,4	9,2
4,6	0,759	136	1,488	9	0,0711	-6	0,495	147	1,50	13,2	9,0
4,7	0,760	134	1,457	7	0,0717	-6	0,499	146	1,51	13,1	8,9
4,8	0,762	133	1,431	6	0,0722	-7	0,503	145	1,51	13,0	8,8
4,9	0,763	132	1,409	4	0,0727	-7	0,506	145	1,51	12,9	8,7
5,0	0,764	131	1,392	3	0,0733	-7	0,509	144	1,50	12,8	8,6

**Typical Common Source S-Parameters (continued)**

$V_{DS} = 5 \text{ V}, I_D = 180 \text{ mA}, Z_o = 50 \Omega$											
f	S11	<S11	S21	<S21	S12	<S12	S22	<S22	k-Fact.	$S_{21}/S_{12}$	MAG
[GHz]	[mag]	[ang]	[mag]	[ang]	[mag]	[ang]	[mag]	[ang]	[mag]	[dB]	[dB]
0,5	0,873	-76	8,549	129	0,0311	50	0,182	-88	0,41	24,4	
0,6	0,850	-81	8,222	127	0,0326	48	0,183	-93	0,48	24,0	
0,7	0,827	-86	7,852	123	0,0342	45	0,186	-98	0,55	23,6	
0,8	0,807	-93	7,457	119	0,0359	42	0,190	-105	0,61	23,2	
0,9	0,793	-100	7,051	114	0,0378	39	0,196	-111	0,65	22,7	
1,0	0,787	-108	6,651	109	0,0398	36	0,205	-117	0,66	22,2	
1,1	0,783	-116	6,269	104	0,0413	33	0,213	-123	0,68	21,8	
1,2	0,778	-123	5,910	99	0,0426	31	0,221	-128	0,71	21,4	
1,3	0,774	-129	5,577	94	0,0437	28	0,228	-133	0,74	21,1	
1,4	0,771	-135	5,270	90	0,0446	26	0,236	-137	0,77	20,7	
1,5	0,768	-140	4,986	86	0,0454	24	0,243	-140	0,81	20,4	
1,6	0,765	-145	4,725	82	0,0460	23	0,250	-143	0,84	20,1	
1,7	0,764	-150	4,485	79	0,0465	21	0,257	-146	0,88	19,8	
1,8	0,762	-154	4,261	75	0,0471	19	0,264	-149	0,91	19,6	
1,9	0,761	-158	4,057	72	0,0475	18	0,272	-151	0,95	19,3	
2,0	0,760	-161	3,869	69	0,0479	16	0,279	-154	0,98	19,1	
2,1	0,759	-165	3,694	66	0,0483	16	0,286	-156	1,02	18,8	18,0
2,2	0,758	-168	3,533	63	0,0484	14	0,292	-158	1,06	18,6	17,1
2,3	0,757	-171	3,384	60	0,0488	14	0,299	-160	1,10	18,4	16,5
2,4	0,757	-174	3,247	57	0,0490	13	0,306	-161	1,13	18,2	16,0
2,5	0,757	-177	3,119	54	0,0492	12	0,313	-163	1,17	18,0	15,5
2,6	0,757	-180	3,000	52	0,0495	11	0,319	-165	1,20	17,8	15,1
2,7	0,756	178	2,889	49	0,0495	11	0,326	-166	1,25	17,7	14,7
2,8	0,756	175	2,786	47	0,0500	10	0,332	-168	1,27	17,5	14,3
2,9	0,756	173	2,689	44	0,0505	9	0,338	-169	1,30	17,3	14,0
3,0	0,756	170	2,598	41	0,0509	9	0,344	-171	1,33	17,1	13,7
3,1	0,757	168	2,514	39	0,0514	8	0,351	-172	1,35	16,9	13,4
3,2	0,757	166	2,434	37	0,0516	8	0,357	-173	1,38	16,7	13,1
3,3	0,757	164	2,360	34	0,0520	8	0,364	-175	1,40	16,6	12,8
3,4	0,757	162	2,289	32	0,0525	8	0,370	-176	1,43	16,4	12,5
3,5	0,757	159	2,222	29	0,0530	8	0,377	-178	1,45	16,2	12,3
3,6	0,758	157	2,158	27	0,0536	7	0,384	-179	1,46	16,0	12,0
3,7	0,758	155	2,097	25	0,0541	7	0,391	180	1,48	15,9	11,8
3,8	0,758	153	2,039	22	0,0546	7	0,399	178	1,50	15,7	11,5
3,9	0,759	151	1,985	20	0,0550	6	0,406	177	1,52	15,6	11,3
4,0	0,759	149	1,932	18	0,0557	6	0,413	175	1,53	15,4	11,1
4,1	0,760	147	1,882	15	0,0563	6	0,420	174	1,54	15,2	10,9
4,2	0,760	145	1,833	13	0,0568	6	0,426	172	1,56	15,1	10,7
4,3	0,761	143	1,786	11	0,0575	5	0,432	171	1,56	14,9	10,5
4,4	0,762	141	1,741	9	0,0580	4	0,438	169	1,58	14,8	10,3
4,5	0,762	139	1,698	7	0,0587	4	0,445	168	1,58	14,6	10,1
4,6	0,763	137	1,657	4	0,0591	3	0,452	166	1,59	14,5	9,9
4,7	0,764	136	1,621	2	0,0596	3	0,458	165	1,60	14,3	9,8
4,8	0,765	134	1,590	1	0,0601	3	0,464	164	1,60	14,2	9,7
4,9	0,766	133	1,564	-1	0,0604	2	0,470	163	1,60	14,1	9,6
5,0	0,768	132	1,544	-2	0,0606	2	0,474	162	1,60	14,1	9,5

Typical Common Source S-Parameters (continued)

V <sub>DS</sub> = 9 V, I <sub>D</sub> = 180 mA, Z <sub>o</sub> = 50 Ω											
f	S11	<S11	S21	<S21	S12	<S12	S22	<S22	k-Fact.	S <sub>21</sub> /S <sub>12</sub>	MAG
[GHz]	[mag]	[ang]	[mag]	[ang]	[mag]	[ang]	[mag]	[ang]	[mag]	[dB]	[dB]
0,5	0,874	-76	8,885	129	0,0245	51	0,272	-48	0,48	25,6	
0,6	0,852	-80	8,544	126	0,0257	48	0,266	-52	0,56	25,2	
0,7	0,829	-86	8,159	122	0,0269	46	0,261	-56	0,64	24,8	
0,8	0,810	-93	7,748	118	0,0283	43	0,256	-60	0,70	24,4	
0,9	0,796	-100	7,326	113	0,0296	40	0,252	-65	0,75	23,9	
1,0	0,791	-108	6,913	108	0,0312	37	0,249	-71	0,76	23,5	
1,1	0,786	-115	6,519	103	0,0324	34	0,248	-77	0,79	23,0	
1,2	0,782	-122	6,147	98	0,0335	32	0,247	-82	0,82	22,6	
1,3	0,778	-128	5,801	93	0,0342	30	0,248	-86	0,86	22,3	
1,4	0,775	-134	5,482	89	0,0350	28	0,249	-91	0,89	21,9	
1,5	0,772	-140	5,187	84	0,0355	27	0,252	-95	0,93	21,6	
1,6	0,770	-144	4,916	81	0,0360	25	0,256	-99	0,97	21,4	
1,7	0,768	-149	4,665	77	0,0363	24	0,260	-103	1,01	21,1	20,4
1,8	0,767	-153	4,433	73	0,0367	22	0,265	-107	1,06	20,8	19,4
1,9	0,766	-157	4,220	70	0,0370	21	0,270	-110	1,10	20,6	18,7
2,0	0,765	-161	4,024	66	0,0371	21	0,277	-114	1,15	20,4	18,0
2,1	0,765	-165	3,840	63	0,0373	20	0,283	-117	1,19	20,1	17,5
2,2	0,764	-168	3,672	60	0,0375	19	0,290	-120	1,23	19,9	17,0
2,3	0,764	-171	3,516	57	0,0377	18	0,297	-123	1,27	19,7	16,5
2,4	0,764	-174	3,372	54	0,0379	17	0,305	-126	1,31	19,5	16,1
2,5	0,764	-177	3,238	51	0,0382	17	0,313	-128	1,35	19,3	15,8
2,6	0,764	-179	3,112	48	0,0385	16	0,320	-131	1,38	19,1	15,4
2,7	0,764	178	2,995	45	0,0386	16	0,328	-133	1,42	18,9	15,0
2,8	0,764	176	2,885	43	0,0388	17	0,337	-136	1,46	18,7	14,7
2,9	0,764	173	2,782	40	0,0393	17	0,344	-138	1,49	18,5	14,4
3,0	0,764	171	2,686	37	0,0396	17	0,352	-140	1,52	18,3	14,1
3,1	0,765	169	2,596	35	0,0400	17	0,360	-142	1,54	18,1	13,8
3,2	0,765	166	2,512	32	0,0406	17	0,368	-145	1,56	17,9	13,5
3,3	0,765	164	2,432	30	0,0411	17	0,377	-147	1,58	17,7	13,3
3,4	0,766	162	2,357	27	0,0416	17	0,386	-149	1,59	17,5	13,0
3,5	0,766	160	2,286	25	0,0422	17	0,394	-151	1,60	17,3	12,8
3,6	0,766	158	2,218	22	0,0429	17	0,403	-153	1,61	17,1	12,5
3,7	0,767	156	2,152	20	0,0436	17	0,411	-155	1,62	16,9	12,3
3,8	0,768	154	2,091	17	0,0444	17	0,420	-157	1,61	16,7	12,1
3,9	0,769	152	2,034	15	0,0451	17	0,428	-159	1,61	16,5	11,9
4,0	0,769	150	1,977	12	0,0458	17	0,436	-162	1,62	16,4	11,7
4,1	0,770	148	1,924	10	0,0466	17	0,445	-164	1,62	16,2	11,6
4,2	0,771	146	1,872	8	0,0472	17	0,452	-166	1,62	16,0	11,4
4,3	0,772	144	1,822	5	0,0481	17	0,460	-168	1,62	15,8	11,2
4,4	0,772	142	1,773	3	0,0491	17	0,468	-170	1,61	15,6	11,0
4,5	0,773	140	1,727	1	0,0500	16	0,476	-172	1,60	15,4	10,8
4,6	0,775	138	1,683	-2	0,0510	16	0,485	-174	1,59	15,2	10,7
4,7	0,776	136	1,644	-4	0,0517	16	0,493	-176	1,58	15,0	10,6
4,8	0,778	135	1,611	-6	0,0527	16	0,500	-177	1,55	14,9	10,5
4,9	0,779	134	1,584	-7	0,0533	16	0,507	-178	1,54	14,7	10,4
5,0	0,781	133	1,562	-9	0,0539	16	0,512	-179	1,52	14,6	10,4

---

**Order Instructions:**

Full type variant including quality level must be specified by the orderer. For *HiRel* Discrete and Microwave Semiconductors the ordering code specifies device family and quality level only.

**Ordering Form:**

Ordering Code: Q.....  
CLY29- (nn) (ql)  
(nn):                      Output Power Level  
(ql):      Quality Level

**Ordering Example:**

Ordering Code: Q62702L116  
CLY29-10 ES  
  
For CLY29; Output Power Level 10 ( $P_{out} > 29.5$  dBm)  
in ESA Space Quality Level

**Further Informations:**

See our WWW-Pages:

- Discrete and RF-Semiconductors (Small Signal Semiconductors)

[www.infineon.com/products/discrete/hirel.htm](http://www.infineon.com/products/discrete/hirel.htm)

- *HiRel* Discrete and Microwave Semiconductors

[www.infineon.com/products/discrete/hirel.htm](http://www.infineon.com/products/discrete/hirel.htm)

Please contact also our marketing division :

Tel.:            ++89 234 24480  
Fax.:            ++89 234 28438  
e-mail:        martin.wimmers@infineon.com  
Address:      Infineon Technologies Semiconductors,  
                 High Frequency Products Marketing,  
                 P.O.Box 801709,  
                 D-81617 Munich



## MWP-25 Package

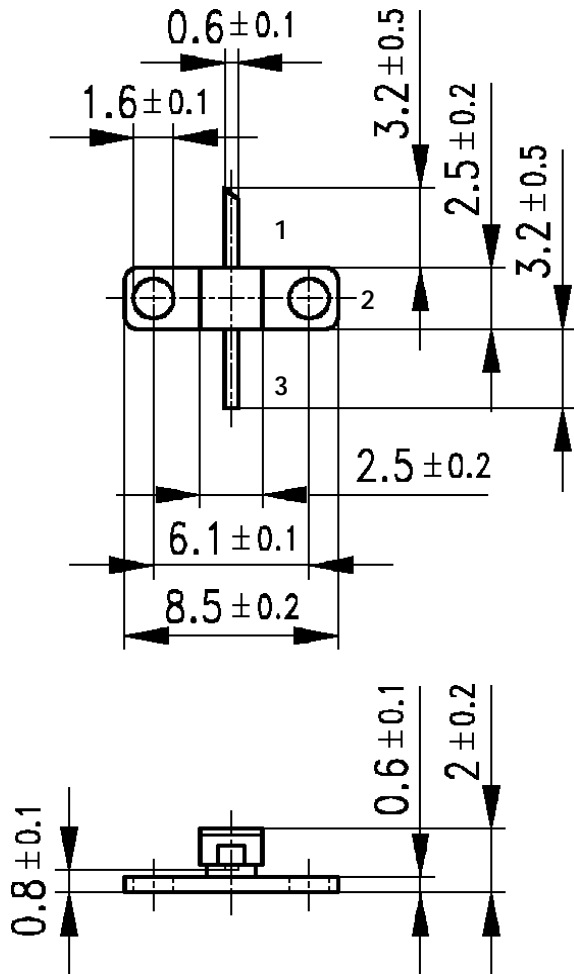

Published by Infineon Technologies Semiconductors, High Frequency Products Marketing, P.O.Box 801709, D-81617 Munich.

Infineon Technologies AG 1998. All Rights Reserved.

As far as patents or other rights of third parties are concerned, liability is only assumed for components per se, not for applications, processes and circuits implemented within components or assemblies.

The information describes the type of component and shall not be considered as assured characteristics.

Terms of delivery and rights to change design reserved.

For questions on technology, delivery and prices please contact the Offices of Semiconductor Group in Germany or the Infineon Technologies Companies and Representatives worldwide (see address list).

Due to technical requirements components may contain dangerous substances. For information on the type in question please contact your nearest Infineon Technologies Office, Semiconductor Group.

Infineon Technologies Semiconductors is a certified CECC and QS9000 manufacturer (this includes ISO 9000).