

# TinySwitch-III<sup>®</sup>

## 28 W Multiple Output Supply with <50 mW No-Load Consumption

Application	Device	Power Output	Input Voltage	Output Voltage	Topology
DVD / Set-top Box	TNY280P	25 W (28 W pk)	90-265 VAC	5 V / 12 V / -12 V / -24 V	Flyback

### Design Highlights

- Simple, low cost, low parts count solution
- Low input power at no-load: <50 mW at 265 VAC
- Low standby power consumption: <90 mW input with 5 V, 5 mA load
- High efficiency: >74% at 90 VAC
- >10 dBμV EMI margin to EN55022B conducted EMI limits, even with output connected to safety earth ground
- Simple output overvoltage latching shutdown circuit protects load under fault conditions
- On-time extension provides 28 ms hold-up time

### Operation

The DVD or set top box supply shown in Figure 1 was designed as a Flyback converter using a TNY280P device (U1). In this circuit, the 10 μF value of C4 selects the increased current limit level of U1, which allows the supply to deliver up to 28 W of peak power during startup or load transients (opening the DVD tray).

The internal MOSFET in U1 conducts current through the primary winding of T1 during each enabled switching cycle. When the primary current reaches the MOSFET current limit, it turns off and the energy in T1 is transferred to the secondary.

The primary clamp (D5, VR3, R1, R2 and C3) limits the maximum peak drain voltage below the 700 V breakdown voltage of the internal MOSFET.

Output overvoltage protection (OVP) is provided by U2, R12, R13, VR1 and VR2. If the feedback loop were to open circuit due to a failure of U3, VR1 or VR2 would turn on U2 causing the current into the BP/M pins of U1 to exceed 6.5 mA, and U1 to latch off. The values of VR1 and VR2 determine the output voltage at which this occurs. Once triggered, cycling the AC power resets the OVP latch.

To reduce no-load input power and increase light-load efficiency, resistor R3 feeds the supply current for U1 from the auxiliary bias winding on the transformer.

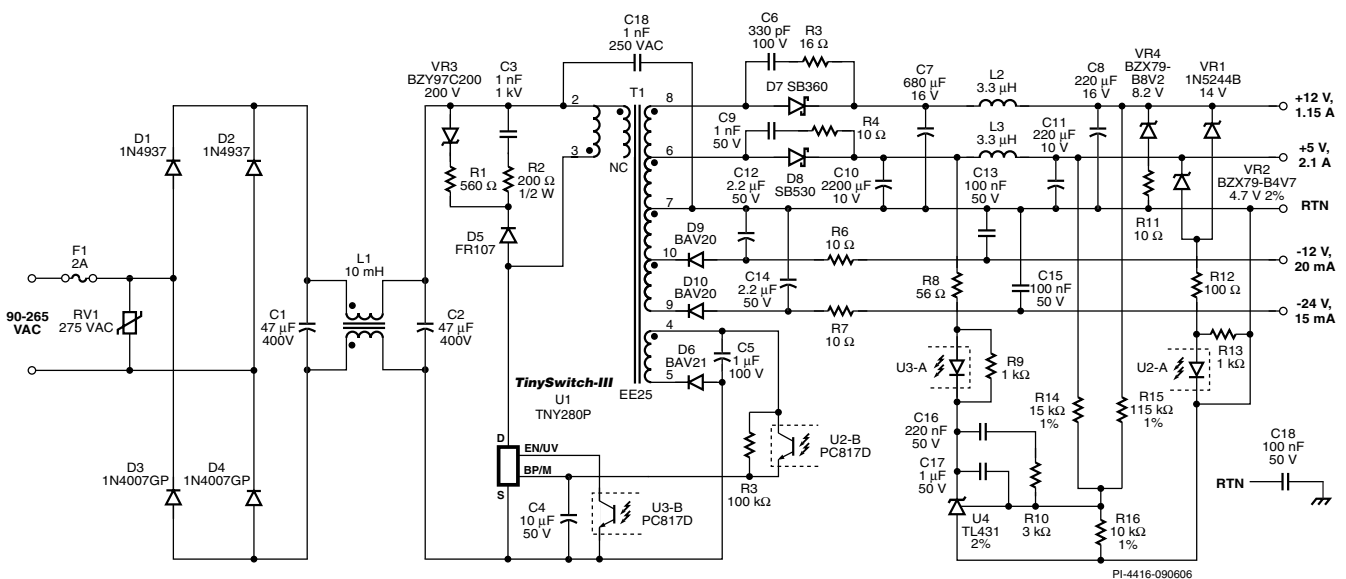

Figure 1. 25 W, 28 W pk Multiple Output Supply Using TNY280P.

## Key Design Points

- The primary clamp of D5, R1, VR3, R2 and C3 is an optimized RCD clamp. During full load, VR3 limits the maximum voltage across C3. At light-load or no-load, as the effective switching frequency is reduced, VR3 prevents C3 from discharging completely. This prevents the clamp network from appearing as a significant load. The use of a fast vs. ultra-fast diode for D5 improves efficiency by recycling some of the leakage energy to the output.

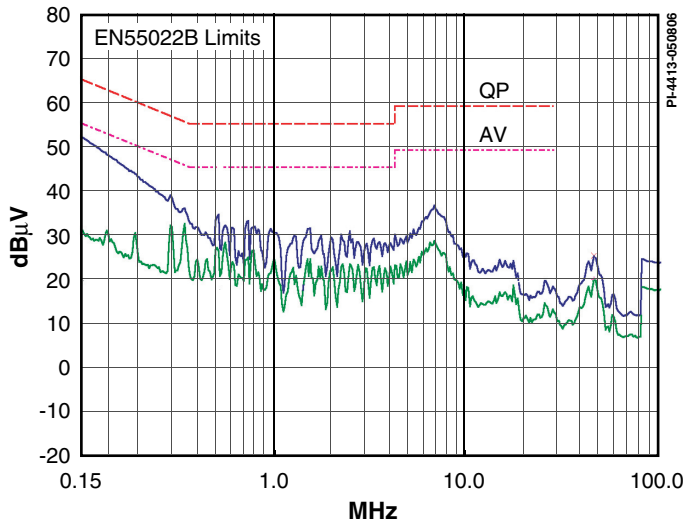

Figure 2. Worst-Case Conducted EMI Results  
(Output Connected to Safety Earth ground).

- Select the value of VR1 and VR2 to limit the maximum voltage during an open loop fault. Resistor R13 provides a bias current so that the Zeners are operated closer to their test current. This bias current also acts as a pre-load.
- For improved cross-regulation, feedback for the power supply is provided from both the 5 V and 12 V output into the voltage reference U4 via R14 and R15.

TRANSFORMER PARAMETERS	
Core Material	EE25, N67 or equivalent, gap for $A_{LG}$ of 105 nH/T <sup>2</sup>
Bobbin	5+5 pin vertical (Yih-Hwa YW-360-02B)
Winding Details	Bias: 27T, 29 AWG Primary: 105T, 32 AWG Shield: 2T, 100 mm × 9 mm × 1 mil Cu foil +5 V: 5T, 2 × 24 AWG T.I.W. +12 V: 6T, 25 AWG T.I.W. -12 V: 11T, 32 AWG T.I.W. -24 V: 11 T, 32 AWG T.I.W.
Winding Order (pin numbers)	1 mm tape margin, bias (4-5), tape, primary (3-2), shield (2-NC), tape, +5 V (6-7), +12 V (8-6), tape, -12 V (7-10), -24 V (10-9), tape
Inductance	Primary: 1.15 mH - 0/+10% Leakage: 70 µH (max)

Table 1. Transformer Design Parameters.

For the latest updates, visit [www.powerint.com](http://www.powerint.com)

Power Integrations reserves the right to make changes to its products at any time to improve reliability or manufacturability. Power Integrations does not assume any liability arising from the use of any device or circuit described herein. POWER INTEGRATIONS MAKES NO WARRANTY HEREIN AND SPECIFICALLY DISCLAIMS ALL WARRANTIES INCLUDING, WITHOUT LIMITATION, THE IMPLIED WARRANTIES OF MERCHANTABILITY, FITNESS FOR A PARTICULAR PURPOSE, AND NON-INFRINGEMENT OF THIRD PARTY RIGHTS. The products and applications illustrated herein (transformer construction and circuits external to the products) may be covered by one or more U.S. and foreign patents or potentially by pending U.S. and foreign patent applications assigned to Power Integrations. A complete list of Power Integrations' patents may be found at [www.powerint.com](http://www.powerint.com). Power Integrations grants its customers a license under certain patent rights as set forth at <http://www.powerint.com/ip.htm>.

The PI logo, **TOPSwitch**, **TinySwitch**, **LinkSwitch**, **DPA-Switch**, **PeakSwitch**, **EcoSmart**, **Clampless**, **E-Shield**, **Filterfuse**, **PI Expert** and **PI FACTS** are trademarks of Power Integrations, Inc. Other trademarks are property of their respective companies. ©Copyright 2006, Power Integrations, Inc.

Power Integrations  
5245 Hellyer Avenue  
San Jose, CA 95138  
Phone: 1-408-414-9200  
Apps: 1-408-414-9660  
Apps Fax: 1-408-414-9760

For a complete listing of worldwide sales offices, please visit [www.powerint.com](http://www.powerint.com)