

INTRODUCTION

This easy-to-use kit provides a platform for the evaluation of PWM amplifiers using the SA01 pin-out configuration. It can be used to analyze a multitude of standard or proprietary circuit configurations, and is flexible enough to do most standard amplifier test configurations. The board is designed for surface mounting all components except the switching amplifier.

The schematic is shown in Figure 2. Note that all of the components shown on the schematic will probably not be used for any single circuit. Some components will simply be omitted, while others require installation of a jumper to complete the signal path.

Only components unique to the EK01 are provided in this kit. Hardware similar to that shown in figure 1 must be obtained locally. The PC board and the foot print of the heatsink measure 3" by 5".

PARTS LIST

Part #	Description	Quantity
HS16	Heatsink	1
MS04	PC mount Cage Jacks	1 Bag/12 each
EVAL07	PC Board	1
60SPG00001	Spacer Grommets	4
TW10	Thermal Washer	1 Box/10 each

ASSEMBLY

1. From the non-silk screen side, insert and solder cage jacks. Be sure each one is fully seated.
2. From the non-silk screen side, push spacer grommets into PC board until fully seated. Grommets will snug when screws are inserted for heatsink mounting.
3. Apply TW10 thermal washer or a thin, even coat of thermal grease to the bottom of the SA01. If grease is from a tube make sure there is no sign separation of solids and liquids. If from a jar, stir it prior to application.
4. Use #14 sleeving to insulate and align at least 2 opposite pins of the amplifier.
5. Mount amplifier to heatsink using #6 screws and nuts. Do not over torque.
6. Install components as needed. External connections may be soldered directly or standard banana jacks may be soldered to these pads.
7. Insert amplifier pins into cage jacks and fasten board to heatsink.

BEFORE YOU GET STARTED

- * All Apex amplifiers should be handled using proper ESD precautions.
- * Always use the heatsink included in this kit with thermal grease.
- * Torque the part to the specified 8 to 10 in-lbs (.9 to 1.13 N*M)
- * Always use adequate power supply bypassing.
- * Do not change connections while the circuit is powered.
- * Initially set all power supplies to the minimum operating levels allowed in the device data sheet.
- * Check for oscillations.

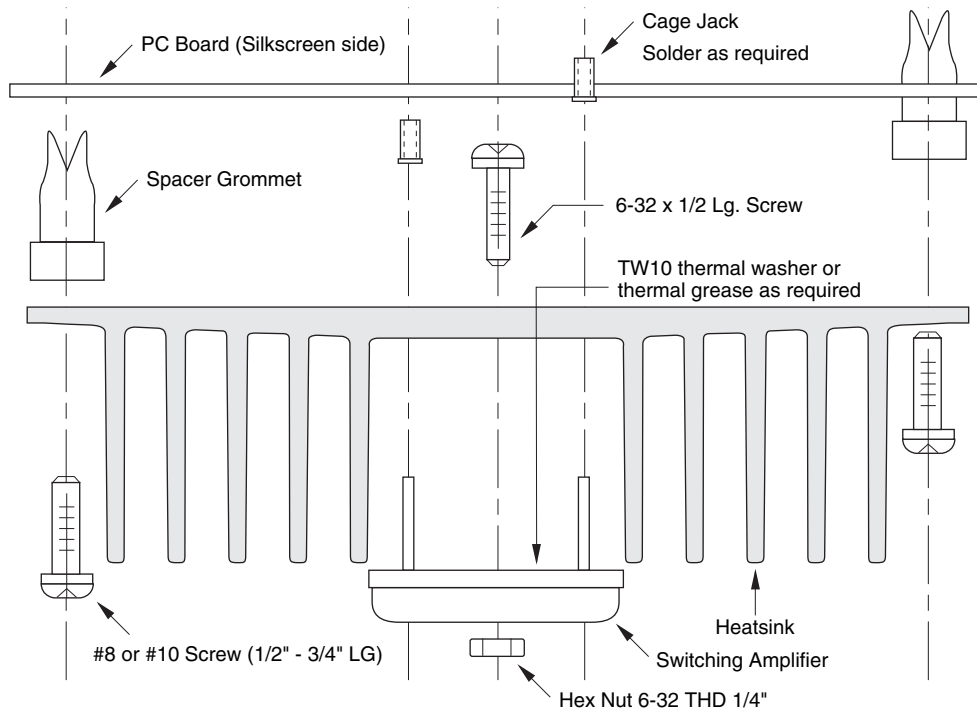
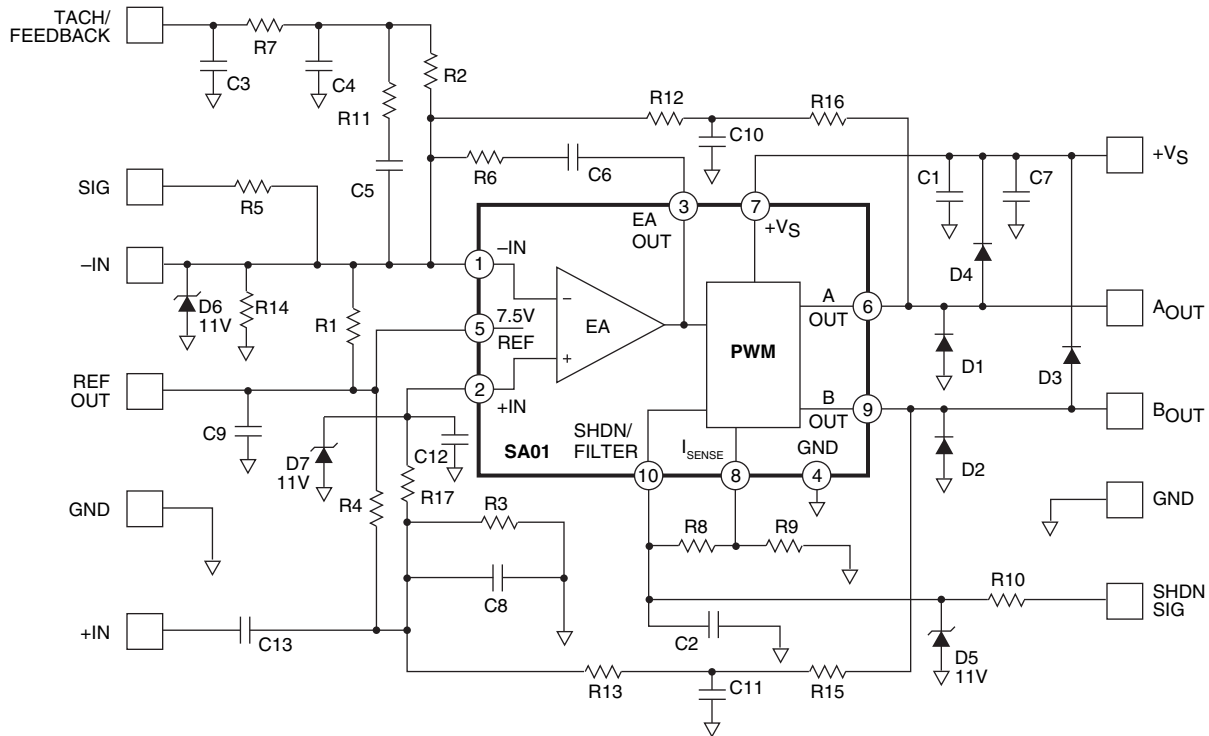

FIGURE 1.

FIGURE 2. PCB SCHEMATIC.



TYPICAL COMPONENT FUNCTIONS

R1	Provides -IN bias from the Reference voltage.
R2	Sets DC scaling for external feedback such as tachometers, position sensors or current sensors.
R3	With R4 sets DC operating point of +IN, with R13 and R15 sets gain of voltage feedback circuit.
R4	With R3 sets DC operating point of +IN.
R5	Input scaling of the control signal.
R6	With C6 sets the corner frequency of the integrator.
R7	With C3 & C4 forms a low pass filter for the external feedback loop. Often used with tachometers.
R8	With C2 forms a low pass filter for the current limit circuit.
R9	Current sense. Often is a piece of resistance wire.
R10	With R8 divides shutdown signal voltage feeding SHDN/FILTER pin.
R11	With C5 sets corner frequency for external feedback loop.
R12, 13, 15, 16	Provides voltage feedback for a voltage controlled output.
R14	Helps set gain or scale input voltage levels.
R17	With C12 provides low pass filtering of +IN signal.
C1	Power supply bypass.
C2	With R8 form a low pass filter for the current limit circuit, also filters the SHDN signal.
C3, 4	With R7 forms a low pass filter for the external feedback loop. Often used with tachometers.
C5	With R11 sets corner frequency for external feedback loop.
C6	With R6 sets the corner frequency of the integrator.
C7	Power supply bypass, must have very low ESR in MHz range.
C8	Filters reference or feedback voltage at +IN.
C9	Bypass for the reference voltage.
C10, 11	With R15 and R16 provides low pass filtering of voltage feedback.
C12	With R17 provides low pass filtering of +IN signal.
C13	Provides AC coupling of +IN signal.
D1 – D4	Optional flyback diodes.
D5 – D7	Input protection zener diodes.

FIGURE 3. PCB

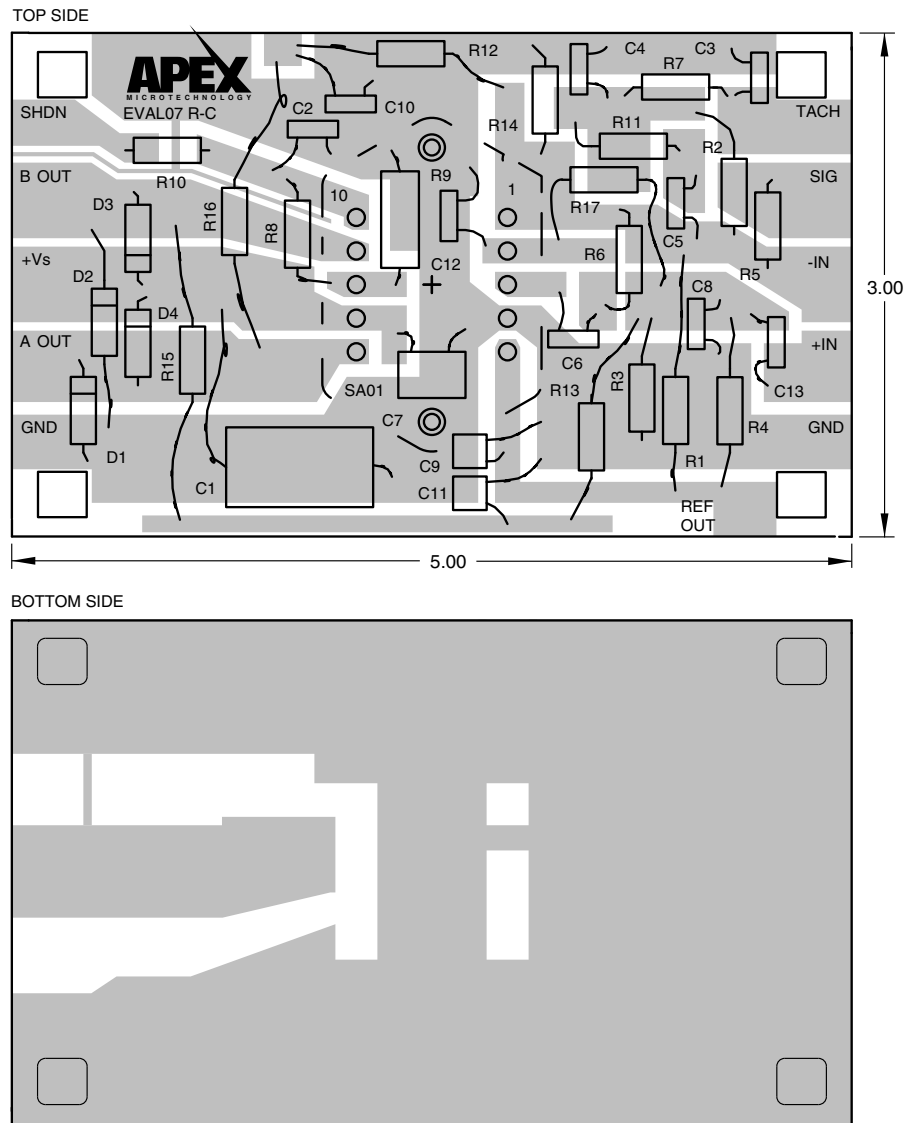

OPEN LOOP OPERATION

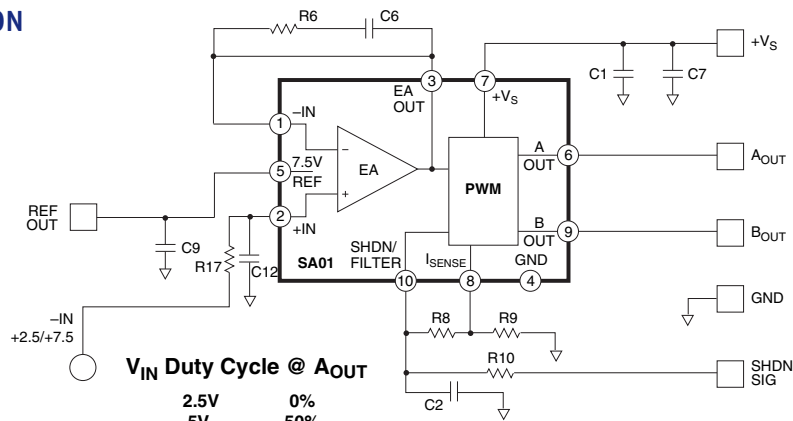

V_{IN} Duty Cycle @ AOUT

2.5V	0%
5V	50%
7.5V	100%

$$(A - B) = \frac{V_{IN} - 5}{2.5} * V_S - I_o * R_{DSON}$$

VOLTAGE CONTROL

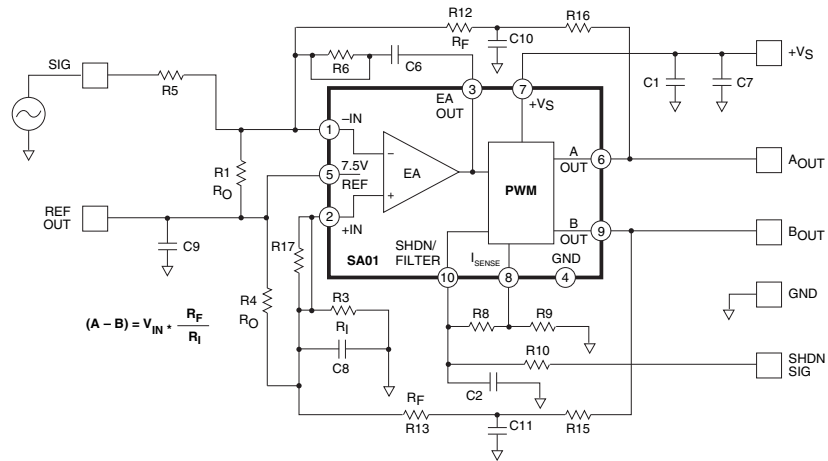

POSITION CONTROL

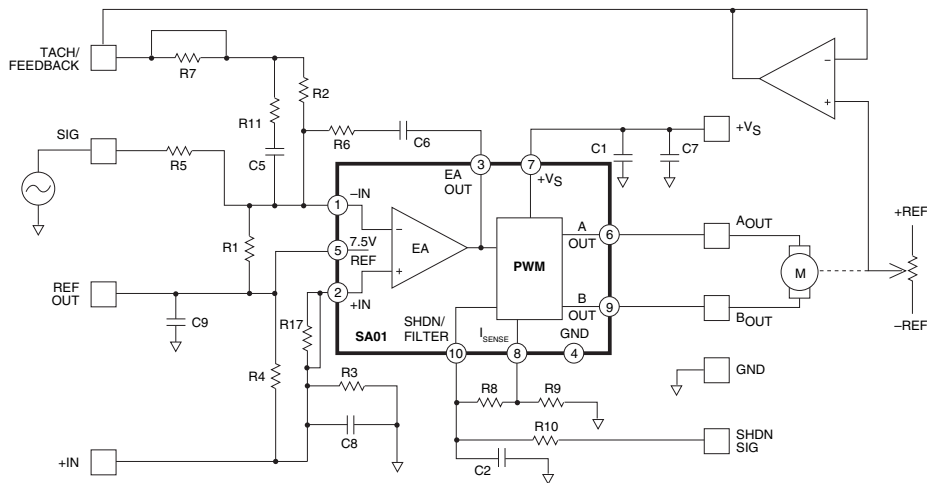

SPEED CONTROL

