



Preliminary

03.05.27

Features

- 5k Ω high transimpedance
- 30dB high gain
- Low noise (typ.3.5pA/ $\sqrt{\text{Hz}}$ @100MHz)
- Typical 900MHz O/E Bandwidth
- Over 30dB wide dynamic range
- 3.3V single Voltage supply operation
- Differential output
- AGC with proper time constant

F0100406B**3.3V 1.25Gbit/s NRZ Receiver
Transimpedance Amplifier**

Applications

- Preamplifier of an optical receiver circuit for GbE (1.25Gbit/s)

Functional Description

The F0100406B is stable GaAs integrated transimpedance amplifier. Typical Applications are for 1.25Gbit/s optical receiver circuit, for example, GbE, instrumentation, and measurement applications. The integrated feedback loop design provides broad bandwidth and stable operation. The F0100406B typically specifies a high transimpedance of 5.0 Ω ($R_L=50\Omega$) at a typical 900MHz O/E bandwidth (-3dB-cutoff frequency) with a dynamic range of over 30dB. It also provides a large optical input overload of more than +2dBm. Furthermore, it can operate with a low supply voltage of single +3.3V. It features a typical dissipation current of 45mA.

Only chip-shipment is available for all product lineups of GaAs transimpedance amplifiers, because the packaged preamplifier cannot operate with the maximum performance owing to parasitic element of the package.

Absolute Maximum Ratings

All published data at Ta=25°C unless otherwise indicated. This device isn't guaranteed opto-electric characteristics in these ranges. At least, this device isn't broken in these ranges.

VSS=0V

Parameter	Symbol	Value	Units	Attentions
Supply Voltage	VDD	-0.3 to +5.0V	V	
Input Current	Iinpeak	4	mA	-
Ambient Operating Temperature	Ta	-40 to +90	°C	-
Storage Temperature	Tstg	-50 to 125	°C	-

Recommended Operating Conditions

VSS=0V, unless specified

Parameter	Symbol	Value			Unit	Attentions
		MIN.	TYP.	MAX.		
Supply Voltage	VDD	3.10	3.30	3.60	V	
Operating Temperature	Tc*	0	25	85	°C	
Input Capacitance	Cpd	-	0.6	-	pF	

* Tc: Back side temperature of wafer

Preliminary

Electrical Characteristics

Tc*=0 to 85°C, VDD=3.1 to 3.6V, VSS=0V, unless specified

Parameters	Symbol	Test Conditions	Value			Units
			MIN.	TYP.	MAX	
Supply Current	IDD	DC	-	45	-	mA
Input Voltage	Vi	*1	-	0.95	-	V
Output Voltage (positive)	Vop	*1	-	2.1	-	V
Output Voltage (negative)	Von	*1	-	2.1	-	V
Gain (positive)	S21p	Single-ended, f=1MHz *1	-	30.0	-	dB
Gain (negative)	S21n	Single-ended, f=1MHz *1	-	30.0	-	dB
-3dB High Frequency Cut-off (positive)	Fcp	S21p-3dB	-	1200	-	MHz
-3dB High Frequency Cut-off (negative)	Fcn	S21p-3dB	-	1100	-	MHz
Input Impedance	Ri	f =1MHz, *1	-	190	-	Ω
Output Impedance (positive)	Rout	f =1MHz, *1	-	55	-	Ω
Output Impedance (negative)	Rout	f =1MHz, *1	-	55	-	Ω
Transimpedance (positive)	Ztp	RL=50Ω, Single-ended, *2	-	5	-	kΩ
Transimpedance (negative)	Ztn	RL=50Ω, Single-ended, *2	-	5	-	kΩ
AGC time constant	Tagc	Cout=470pF	-	24	-	μsec

* Tc: Back side temperature of wafer

*1 Test circuit is shown [Test Circuits / 1] AC Characteristics].

*2 $Z_t(p,n) = 10 \wedge (S21(p,n)/20) \times (R_i + 50) / 2$

Optical and Electrical Characteristics

This table values are specified on condition of F0832483T. F0832483T is 2.5Gbps NRZ PIN-PD preamplifier module using F0100504B. Test circuits of F0832483T are shown in [Test Circuits].

λ=1.3μm, VDD=VPD=+3.1~+3.6V, VSS=GND, Tcm*3=-20~+85°C, unless specified

Parameters	Symbol	Test Conditions	Value			Unit
			MIN.	TYP.	MAX	
Transimpedance	Ztm	RL=50Ω, Single-ended, f =100MHz, *4	-	5	-	kΩ
O/E High Cut-off Frequency	Fcoeh	Ztm-3dB, *4	-	900	-	MHz
O/E Low Cut-off Frequency	Fcoel	Cout=470pF	-	17	-	kHz
Equivalent Input Noise	Inoise	f =100MHz	-	3.5	-	pA/√Hz
Sensitivity	Pin-min	2.48832Gbps, PRBS2^23-1, BER=1E-10, *5	-	-29	-	dBm
Overload	Pin-max		+1	-	-	dBm
Output Impedance	Routm	No input, f=1MHz, *4	-	55	-	Ω

*3 Tcm : case temperature

*4 Show [Test Circuits / 3] Optical & Electrical Characteristics].

*5 Show [Test Circuits / 4] Sensitivity Characteristics].

Block Diagram

Preliminary

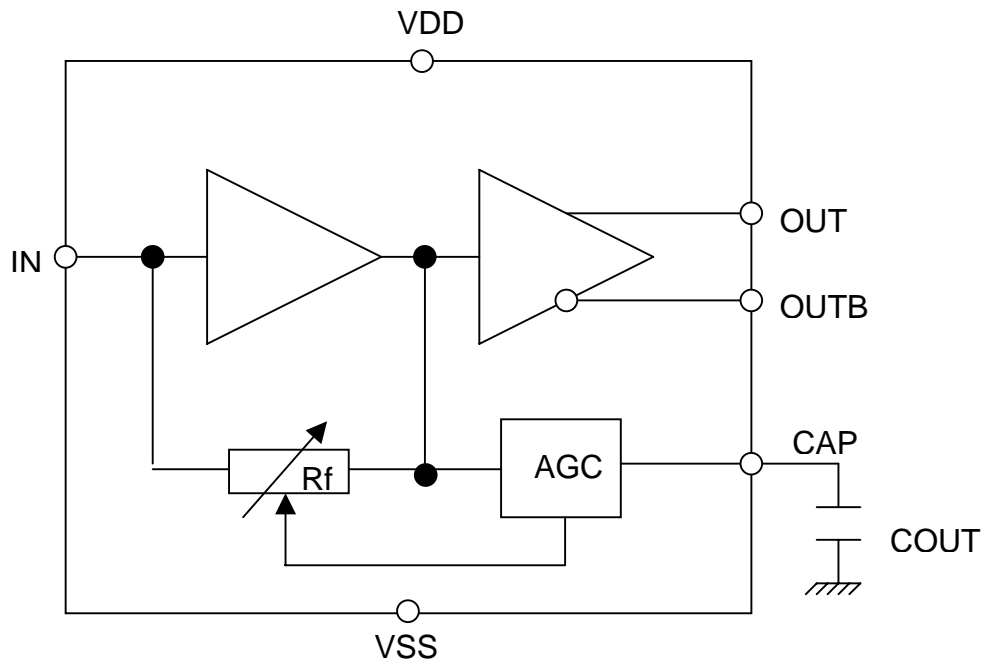

Symbol	Description
VDD	Supply Voltage
VSS	Supply Voltage Generally Vss is connected to GND.
IN	Input
OUT	Non-inverted data output, must be AC coupled.
OUTB	Inverted data output, must be AC coupled.
CAP	Connected to outer capacitance

Die Pad Assignment

Preliminary

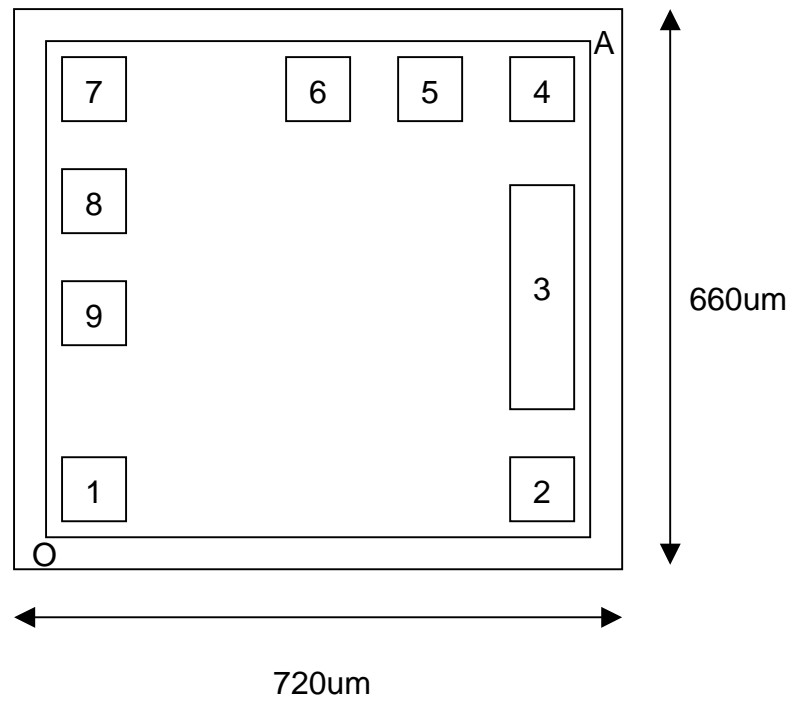

No.	Symbol	Center Coordinates (um)	No.	Symbol	Center Coordinates (um)
1	VDD	(65,65)	7	CAP	(65,565)
2	OUTB	(625,65)	8	VSS	(65,415)
3	VSS	(625,315)	9	IN	(65,265)
4	OUT	(625,565)			
5	VSS	(420,565)	O		(0,0)
6	VDD	(270,565)	A		(790,790)

Test Circuits

1) AC Characteristics

Preliminary

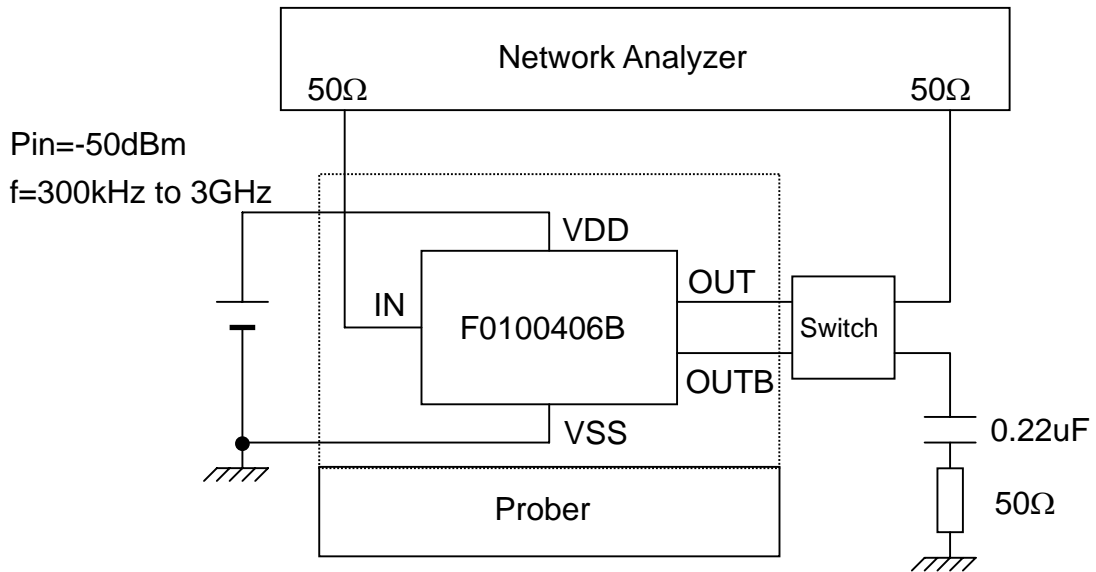

2) Block Diagram of F0831252T

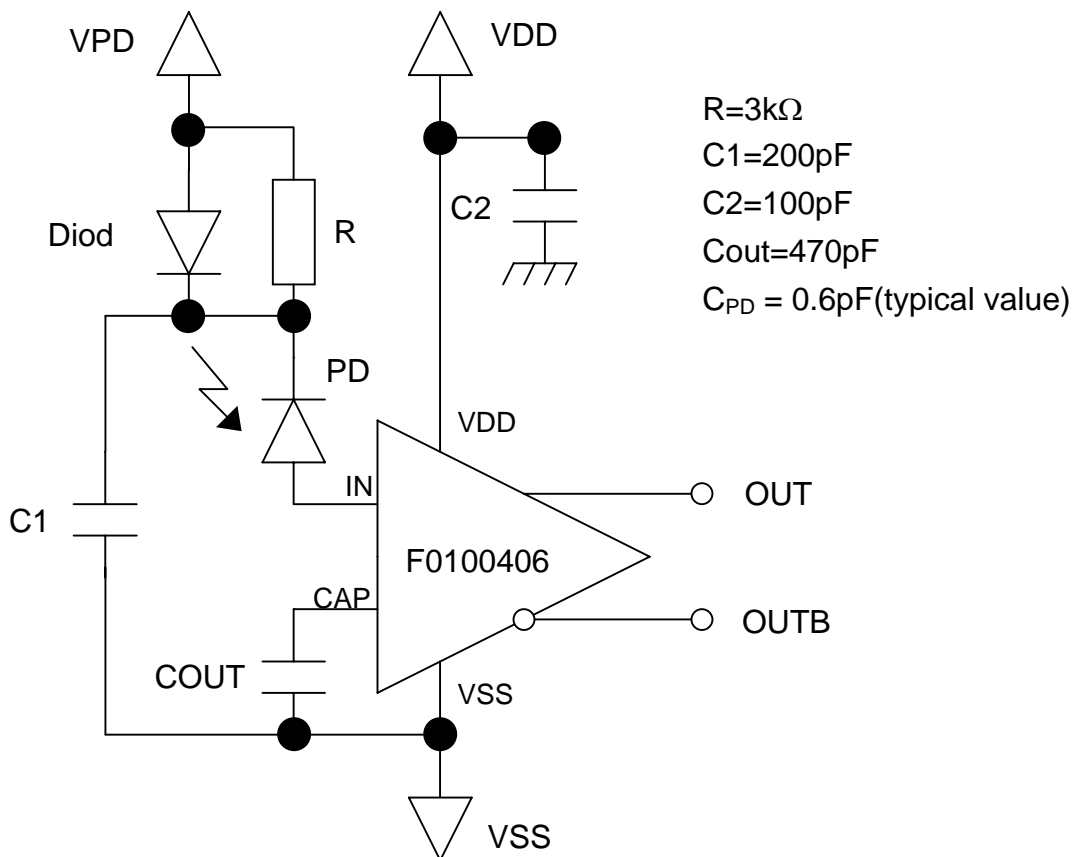

3) Optical & Electrical Characteristics

Preliminary

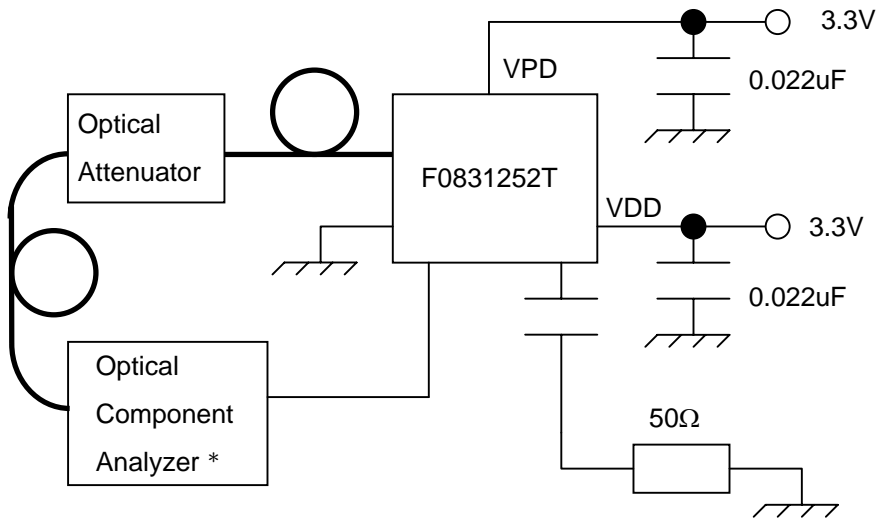

* Agilent 8702 Systems

4) Sensitivity Characteristics

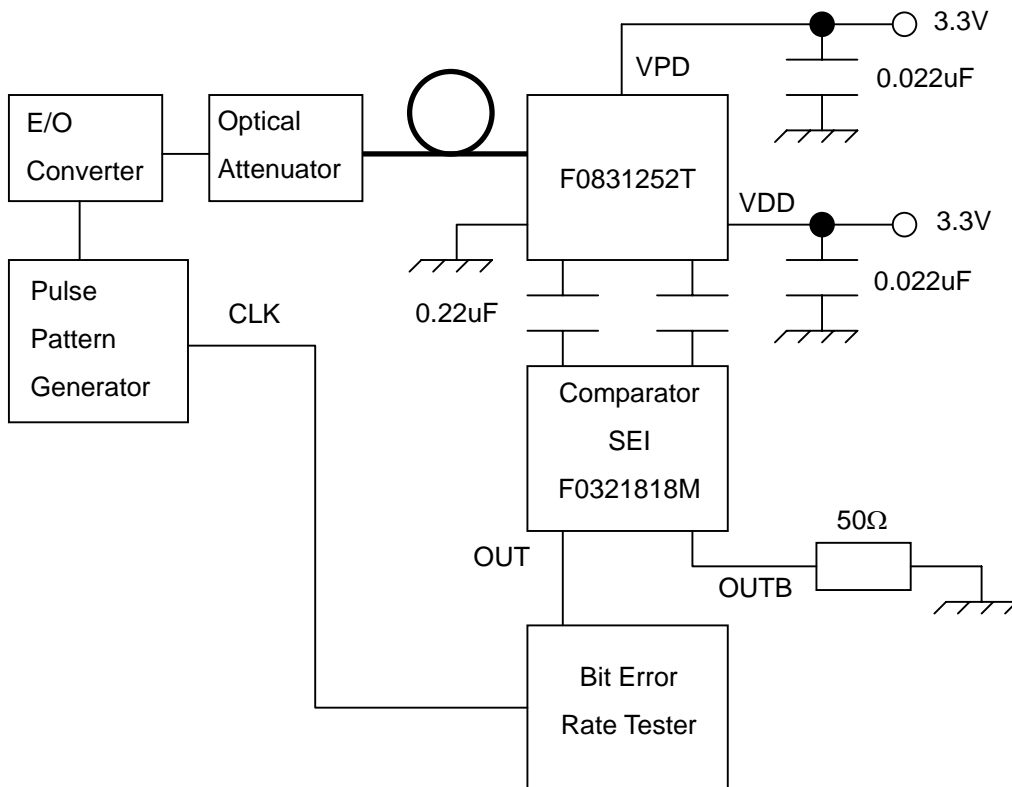

F0100406B

3.3V 1.25Gbit/s Transimpedance Amplifier

Examples of AC Characteristics

Preliminary

NOW PRINTING

General Description

A transimpedance amplifier is applied as a pre-amplifier which is an amplifier for a faint photo current from a PIN photo diode (PD). The performance in terms of sensitivity, bandwidth, and so on, obtained by this transimpedance amplifier strongly depend on the capacitance brought at the input terminal; therefore, "typical", "minimum", or "maximum" parameter descriptions can not always be achieved according to the employed PD and package, the assembling design, and other technical experts. This is the major reason that there is no product lineup of packaged transimpedance amplifiers.

Thus, for optimum performance of the transimpedance amplifier, it is essential for customers to design the input capacitance carefully.

Hardness to electro-magnetic interference and fluctuation of a power supply voltage is also an important point of the design, because very faint photo-current flows into the transimpedance amplifier. Therefore, in the assembly design of the interconnection between a PD and a transimpedance, noise should be taken into consideration.

Recommendation

SEI basically recommends The F08 series PD preamplifier modules for customers of the transimpedance amplifiers. In these modules, a transimpedance amplifier, a PD, and a noise filter circuit are mounted on a TO-18-can package hermetically sealed by a lens cap, having typically a fiber pigtail. The F08series lineups are the best choice for customers to using the F01series transimpedance amplifiers. SEI's F08 series allows the customers to resolve troublesome design issues and to shorten the development lead time.

Noise Performance

F0100406B based on GaAs MES FET's shows excellent low-noise characteristics compared with IC's based on the silicon bipolar process. Many transmission systems often demand superior signal-to-noise ratio, that is, high sensitivity; F0100406B is the best Choice for such applications.

The differential circuit configuration in the output enable a complete differential operation to reduce common mode noise: simple single ended output operation is also available.

Die-Chip Description

F0100406B is shipped like the die-chip described above. The die thickness is typically $280\mu\text{m} \pm 20\mu\text{m}$ with the available pad size uncovered by a passivation film of $95\mu\text{m}$ square. The material of the pads is TiW/Pt/Au and the backside is metalized by Ti/Au.

Preliminary

Assembling Condition

SEI recommends the assembling process as shown below and affirms sufficient wire-pull and die share strength. The heating time of one minute at the temperature of 310°C gave satisfactory results for die-bonding with AuSn preforms. The heating and ultrasonic wire-bonding at the temperature of 150°C by a ball-bonding machine effective.

Quality Assurance

For the F01 series products, there is only one technically inevitable drawback in terms of quality assurance which is to be impossible of the burn-in test for screening owing to die-shipment. SEI will not ship them if customers do not agree on this point. On the other hand, the lot assurance test is performed completely without any problems according to SEI's authorized rules. A microscope inspection is conducted in conformance with the MIL-STD-883C Method 2010.7.

Precautions

Owing to their small dimensions, the GaAsFET's from which the F0100406B is designed are easily damaged or destroyed if subjected to large transient voltages. Such transients can be generated by power supplies when switched on if not properly decoupled. It is also possible to induce spikes from static-electricity-charged operations or ungrounded equipment.